

CHAPTER – 1 REAL NUMBERS

The Fundamental Theorem of Arithmetic

Every composite number can be expressed (factorised) as a product of primes, and this factorisation is unique, apart from the order in which the prime factors occur.

The prime factorisation of a natural number is unique, except for the order of its factors.

❖ Property of HCF and LCM of two positive integers 'a' and 'b':

➤ $HCF(a,b) \times LCM(a,b) = a \times b$

➤ $LCM(a,b) = \frac{a \times b}{HCF(a,b)}$

➤ $HCF(a,b) = \frac{a \times b}{LCM(a,b)}$

PRIME FACTORISATION METHOD TO FIND HCF AND LCM

HCF(a, b) = Product of the smallest power of each common prime factor in the numbers.

LCM(a, b) = Product of the greatest power of each prime factor, involved in the numbers.

IMPORTANT QUESTIONS

1. Find the HCF and LCM of 6, 72 and 120, using the prime factorisation method.
2. Find the HCF of 96 and 404 by the prime factorisation method. Hence, find their LCM.
3. Find the LCM and HCF of the following pairs of integers and verify that $LCM \times HCF =$ product of the two numbers: (i) 26 and 91 (ii) 336 and 54
4. Find the LCM and HCF of the following integers by applying the prime factorisation method: (i) 12, 15 and 21 (ii) 17, 23 and 29 (iii) 8, 9 and 25
5. Find the LCM and HCF of 510 and 92 and verify that $LCM \times HCF =$ product of the two numbers
6. Explain why $3 \times 5 \times 7 + 7$ is a composite number.
7. Can the number 6^n , n being a natural number, end with the digit 5? Give reasons.
8. Can the number 4^n , n being a natural number, end with the digit 0? Give reasons.
9. Given that $HCF(306, 657) = 9$, find $LCM(306, 657)$.
10. If two positive integers a and b are written as $a = x^3y^2$ and $b = xy^3$; x, y are prime numbers, then find the HCF (a, b).
11. If two positive integers p and q can be expressed as $p = ab^2$ and $q = a^3b$; a, b being prime numbers, then find the LCM (p, q).
12. Using prime factorization, find the HCF and LCM of (i) 36, 84 (ii) 23, 31 (iii) 96, 404 (iv) 144, 198 (v) 396, 1080 (vi) 1152, 1664
13. The HCF of two numbers is 23 and their LCM is 1449. If one of the numbers is 161, find the other.
14. The HCF of two numbers is 145 and their LCM is 2175. If one of the numbers is 725, find the other.
15. The HCF of two numbers is 18 and their product is 12960. Find their LCM.
16. Find the largest number which divides 245 and 1029 leaving remainder 5 in each case.
17. Find the largest number which divides 2053 and 967 and leaves a remainder of 5 and 7 respectively.
18. Two tankers contain 850 litres and 680 litres of kerosene oil respectively. Find the maximum capacity of a container which can measure the kerosene oil of both the tankers when used an exact number of times.

19. In a morning walk, three persons step off together. Their steps measure 80 cm, 85 cm and 90 cm respectively. What is the minimum distance each should walk so that all can cover the same distance in complete steps?
20. Find the least number which when divided by 12, 16, 24 and 36 leaves a remainder 7 in each case.
21. The length, breadth and height of a room are 825 cm, 675 cm and 450 cm respectively. Find the longest tape which can measure the three dimensions of the room exactly.
22. Three measuring rods are 64 cm, 80 cm and 96 cm in length. Find the least length of cloth that can be measured an exact number of times, using any of the rods.
23. Prove that $\sqrt{2}$ is an irrational number.
24. Prove that $\sqrt{3}$ is an irrational number.
25. Prove that $\sqrt{5}$ is an irrational number.
26. Prove that $\sqrt{7}$ is an irrational number.
27. Prove that $2 + 5\sqrt{3}$ is an irrational number.
28. Prove that $3 - 2\sqrt{5}$ is an irrational number.
29. Prove that $\sqrt{3} + \sqrt{5}$ is an irrational number.
30. Prove that $\sqrt{2} - \sqrt{5}$ is an irrational number.

MCQ (1 mark)

1. If HCF and LCM of two numbers are 4 and 9696, then the product of the two numbers is:
 (a) 9696 (b) 24242 (c) 38784 (d) 4848
2. If a and b are positive integers, then $\text{HCF}(a, b) \times \text{LCM}(a, b) =$
 (a) $a \times b$ (b) $a + b$ (c) $a - b$ (d) a/b
3. The HCF of 52 and 130 is
 (a) 52 (b) 130 (c) 26 (d) 13
4. If the HCF of two numbers is 1, then the two numbers are called
 (a) composite (b) relatively prime or co-prime
 (c) perfect (d) irrational numbers
5. Given that $\text{HCF}(1152, 1664) = 128$ the $\text{LCM}(1152, 1664)$ is
 (a) 14976 (b) 1664 (c) 1152 (d) none of these
6. The HCF of two numbers is 23 and their LCM is 1449. If one of the numbers is 161, then the other number is
 (a) 23 (b) 207 (c) 1449 (d) none of these
7. Which one of the following rational number is a non-terminating decimal expansion:
 (a) $\frac{33}{50}$ (b) $\frac{66}{180}$ (c) $\frac{6}{15}$ (d) $\frac{41}{1000}$
8. The product of L.C.M and H.C.F. of two numbers is equal to
 (a) Sum of numbers (b) Difference of numbers
 (c) Product of numbers (d) Quotients of numbers

9. L.C.M. of two co-prime numbers is always
 (a) product of numbers (b) sum of numbers
 (c) difference of numbers (d) none
10. What is the H.C.F. of two consecutive even numbers
 (a) 1 (b) 2 (c) 4 (d) 8
11. What is the H.C.F. of two consecutive odd numbers
 (a) 1 (b) 2 (c) 4 (d) 8
12. The missing number in the following factor tree is
 (a) 2 (b) 6 (c) 3 (d) 9

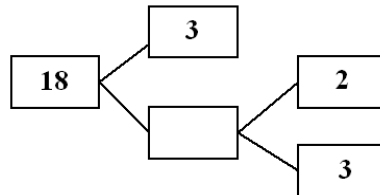

CHAPTER – 2 POLYNOMIALS

QUADRATIC POLYNOMIAL

Relationship between zeroes and coefficients

General form of Quadratic polynomial: $ax^2 + bx + c$, $a \neq 0$

$$\text{Sum of zeroes } (\alpha + \beta) = -\frac{\text{Coefficient of } x}{\text{Coefficient of } x^2} = -\frac{b}{a}$$

$$\text{Product of zeroes } (\alpha\beta) = \frac{\text{Constant term}}{\text{Coefficient of } x^2} = \frac{c}{a}$$

IMPORTANT QUESTIONS

Find a quadratic polynomial, the sum and product of whose zeroes are -3 and 2 , respectively.

Solution: Here, $\alpha + \beta = -3$ and $\alpha\beta = 2$

We know that quadratic polynomial is given by $p(x) = x^2 - (\alpha + \beta)x + \alpha\beta$

$$= x^2 - (-3)x + 2 = x^2 + 3x + 2$$

Hence, required quadratic polynomial is $x^2 + 3x + 2$

Find a quadratic polynomial, whose zeroes are -3 and 2 .

Solution: Here, $\alpha = -3$ and $\beta = 2$.

Now, $\alpha + \beta = -3 + 2 = -1$ and $\alpha\beta = (-3)(2) = -6$

We know that quadratic polynomial is given by $p(x) = x^2 - (\alpha + \beta)x + \alpha\beta$

$$= x^2 - (-1)x + (-6) = x^2 + x - 6$$

Hence, required quadratic polynomial is $x^2 + x - 6$

Find the zeroes of the quadratic polynomial $x^2 - 2x - 8$ and verify the relationship between the zeroes and the coefficients.

Solution: Here, $p(x) = x^2 - 2x - 8 = 0$

$$x^2 - 4x + 2x - 8 = 0 \Rightarrow x(x - 4) + 2(x - 4) = 0 \Rightarrow (x - 4)(x + 2) = 0$$

$$\Rightarrow x = 4, -2$$

Now, $a = 1$, $b = -2$, $c = -8$, $\alpha = 4$, $\beta = -2$

Sum of zeroes, $\alpha + \beta = 4 + (-2) = 2$ and $\frac{-b}{a} = \frac{-(-2)}{1} = 2 \quad \therefore \alpha + \beta = \frac{-b}{a}$

Product of zeroes, $\alpha\beta = 4(-2) = -8$ and $\frac{c}{a} = \frac{-8}{1} = -8 \quad \therefore \alpha\beta = \frac{c}{a}$.

Hence verified.

Questions for practice

1. Find a quadratic polynomial, the sum and product of whose zeroes are -5 and 3 , respectively.
2. Find a quadratic polynomial, whose zeroes are -4 and 1 , respectively.
3. Find the zeroes of the quadratic polynomial $x^2 + 7x + 10$, and verify the relationship between the zeroes and the coefficients.
4. Find the zeroes of the polynomial $x^2 - 3$ and verify the relationship between the zeroes and the coefficients.
5. Find the zeroes of the quadratic polynomial $6x^2 - 3 - 7x$ and verify the relationship between the zeroes and the coefficients.
6. Find the zeroes of the quadratic polynomial $3x^2 - x - 4$ and verify the relationship between the zeroes and the coefficients.
7. Find the zeroes of the quadratic polynomial $4x^2 - 4x + 1$ and verify the relationship between the zeroes and the coefficients.

MCQ (1 MARK)

1. The value of k for which (-4) is a zero of the polynomial $x^2 - x - (2k + 2)$ is
(a) 3 (b) 9 (c) 6 (d) -1
2. If the zeroes of the quadratic polynomial $ax^2 + bx + c$, $c \neq 0$ are equal, then
(a) c and a have opposite sign (b) c and b have opposite sign
(c) c and a have the same sign (d) c and b have the same sign
3. The number of zeroes of the polynomial from the graph is
(a) 0 (b) 1 (c) 2 (d) 3
4. If one of the zero of the quadratic polynomial $x^2 + 3x + k$ is 2 , then the value of k is
(a) 10 (b) -10 (c) 5 (d) -5
5. A quadratic polynomial whose zeroes are -3 and 4 is
(a) $x^2 - x + 12$ (b) $x^2 + x + 12$ (c) $2x^2 + 2x - 24$. (d) none of the above.
6. The relationship between the zeroes and coefficients of the quadratic polynomial $ax^2 + bx + c$ is
(a) $\alpha + \beta = \frac{c}{a}$ (b) $\alpha + \beta = \frac{-b}{a}$ (c) $\alpha + \beta = \frac{-c}{a}$ (d) $\alpha + \beta = \frac{b}{a}$
7. The zeroes of the polynomial $x^2 + 7x + 10$ are
(a) 2 and 5 (b) -2 and 5 (c) -2 and -5 (d) 2 and -5
8. The relationship between the zeroes and coefficients of the quadratic polynomial $ax^2 + bx + c$ is
(a) $\alpha.\beta = \frac{c}{a}$ (b) $\alpha.\beta = \frac{-b}{a}$ (c) $\alpha.\beta = \frac{-c}{a}$ (d) $\alpha.\beta = \frac{b}{a}$
9. The zeroes of the polynomial $x^2 - 3$ are

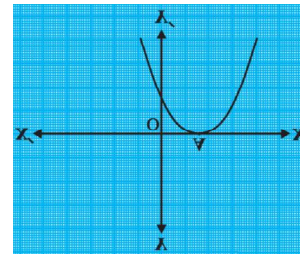

- (a) 2 and 5 (b) -2 and 5 (c) -2 and -5 (d) none of the above

10. The number of zeroes of the polynomial from the graph is

- (a) 0 (b) 1 (c) 2 (d) 3

11. A quadratic polynomial whose sum and product of zeroes are -3 and 2 is

- (a) $x^2 - 3x + 2$ (b) $x^2 + 3x + 2$ (c) $x^2 + 2x - 3$ (d) $x^2 + 2x + 3$

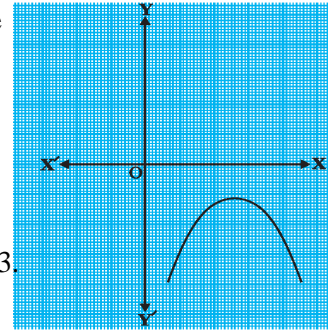

12. Which of the following is a polynomial?

- (a) $x^2 - 5x + 3$
 (b) $\sqrt{x} + \frac{1}{\sqrt{x}}$
 (c) $x^{3/2} - x + x^{1/2}$
 (d) $x^{1/2} + x + 10$

13. Which of the following is not a polynomial?

- (a) $\sqrt{3}x^2 - 2\sqrt{3}x + 3$
 (b) $\frac{3}{2}x^3 - 5x^2 - \frac{1}{\sqrt{2}}x - 1$
 (c) $x + \frac{1}{x}$
 (d) $5x^2 - 3x + \sqrt{2}$

14. If α, β are the zeroes of the polynomials $f(x) = x^2 + 5x + 8$, then $\alpha + \beta$

- (a) 5 (b) -5 (c) 8 (d) none of these

15. If α, β are the zeroes of the polynomials $f(x) = x^2 + 5x + 8$, then $\alpha\beta$

- (a) 0 (b) 1 (c) -1 (d) none of these

16. Which of the following is a polynomial:

- (a) $x^2 + \frac{1}{x}$ (b) $2x^2 - 3\sqrt{x} + 1$ (c) $x^2 + x^{-2} + 7$ (d) $3x^2 - 3x + 1$

17. The product and sum of zeroes of the quadratic polynomial $ax^2 + bx + c$ respectively are:

- (a) $\frac{b}{a}, \frac{c}{a}$ (b) $\frac{c}{a}, \frac{b}{a}$ (c) $\frac{c}{b}, 1$ (d) $\frac{c}{a}, -\frac{b}{a}$

18. The zeroes of the quadratic polynomial $x^2 + kx + k, k \neq 0$,

- (a) cannot both be positive (b) cannot both be negative
 (c) are always unequal (d) are always equal

19. A quadratic polynomial can have at most zeroes

- (a) 0 (b) 1 (c) 2 (d) 3

20. A cubic polynomial can have at most zeroes.

- (a) 0 (b) 1 (c) 2 (d) 3

21. Which are the zeroes of $p(x) = x^2 - 1$:

- (a) 1, -1 (b) -1, 2 (c) -2, 2 (d) -3, 3

22. Which are the zeroes of $p(x) = (x - 1)(x - 2)$:

- (a) 1, -2 (b) -1, 2 (c) 1, 2 (d) -1, -2

CHAPTER – 3 PAIR OF LINEAR EQUATIONS IN TWO VARIABLES

ALGEBRAIC INTERPRETATION OF PAIR OF LINEAR EQUATIONS IN TWO VARIABLES

The pair of linear equations represented by these lines $a_1x + b_1y + c_1 = 0$ and $a_2x + b_2y + c_2 = 0$

1. If $\frac{a_1}{a_2} \neq \frac{b_1}{b_2}$ then the pair of linear equations has exactly one solution.
2. If $\frac{a_1}{a_2} = \frac{b_1}{b_2} = \frac{c_1}{c_2}$ then the pair of linear equations has infinitely many solutions.
3. If $\frac{a_1}{a_2} = \frac{b_1}{b_2} \neq \frac{c_1}{c_2}$ then the pair of linear equations has no solution.

S. No.	Pair of lines	Compare the ratios	Graphical representation	Algebraic interpretation
1	$a_1x + b_1y + c_1 = 0$ $a_2x + b_2y + c_2 = 0$	$\frac{a_1}{a_2} \neq \frac{b_1}{b_2}$	Intersecting lines	Unique solution (Exactly one solution)
2	$a_1x + b_1y + c_1 = 0$ $a_2x + b_2y + c_2 = 0$	$\frac{a_1}{a_2} = \frac{b_1}{b_2} = \frac{c_1}{c_2}$	Coincident lines	Infinitely many solutions
3	$a_1x + b_1y + c_1 = 0$ $a_2x + b_2y + c_2 = 0$	$\frac{a_1}{a_2} = \frac{b_1}{b_2} \neq \frac{c_1}{c_2}$	Parallel lines	No solution

IMPORTANT QUESTIONS

1. On comparing the ratios $\frac{a_1}{a_2} = \frac{b_1}{b_2} = \frac{c_1}{c_2}$, find out whether the lines representing the following pairs of linear equations intersect at a point, are parallel or coincident:
 - (i) $5x - 4y + 8 = 0$ and $7x + 6y - 9 = 0$
 - (ii) $9x + 3y + 12 = 0$ and $18x + 6y + 24 = 0$
 - (iii) $6x - 3y + 10 = 0$ and $2x - y + 9 = 0$.
2. On comparing the ratios $\frac{a_1}{a_2} = \frac{b_1}{b_2} = \frac{c_1}{c_2}$, find out whether the following pair of linear equations are consistent, or inconsistent.
 - (i) $3x + 2y = 5$; $2x - 3y = 7$
 - (ii) $2x - 3y = 8$; $4x - 6y = 9$
 - (iii) $5x - 3y = 11$; $-10x + 6y = -22$
3. Find the number of solutions of the following pair of linear equations:

$$x + 2y - 8 = 0$$

$$2x + 4y = 16$$
4. Write whether the following pair of linear equations is consistent or not.

$$x + y = 14, x - y = 4$$
5. Given the linear equation $3x + 4y - 8 = 0$, write another linear equation in two variables such that the geometrical representation of the pair so formed is parallel lines.

6. Find the value of k so that the following system of equations has no solution:
 $3x - y - 5 = 0$, $6x - 2y + k = 0$
7. Find the value of k so that the following system of equation has infinite solutions:
 $3x - y - 5 = 0$, $6x - 2y + k = 0$
8. For which values of p , does the pair of equations given below has unique solution?
 $4x + py + 8 = 0$ and $2x + 2y + 2 = 0$
9. Determine k for which the system of equations has infinite solutions:
 $4x + y = 3$ and $8x + 2y = 5k$
10. Find whether the lines representing the following pair of linear equations intersect at a point, are parallel or coincident:
 $2x - 3y + 6 = 0$; $4x - 5y + 2 = 0$
11. Find the value of k for which the system $3x + ky = 7$, $2x - 5y = 1$ will have infinitely many solutions.
12. For what value of k , the system of equations $2x - ky + 3 = 0$, $4x + 6y - 5 = 0$ is consistent?
13. For what value of k , the system of equations $kx - 3y + 6 = 0$, $4x - 6y + 15 = 0$ represents parallel lines?
14. For what value of p , the pair of linear equations $5x + 7y = 10$, $2x + 3y = p$ has a unique solution.
15. Find the value of m for which the pair of linear equations has infinitely many solutions.
 $2x + 3y - 7 = 0$ and $(m - 1)x + (m + 1)y = (3m - 1)$
16. For what value of p will the following pair of linear equations have infinitely many solutions?
 $(p - 3)x + 3y = p$; $px + py = 12$
17. For what value of k will the system of linear equations has infinite number of solutions?
 $kx + 4y = k - 4$, $16x + ky = k$
18. Find the values of a and b for which the following system of linear equations has infinite number of solutions:
 $2x - 3y = 7$, $(a + b)x - (a + b - 3)y = 4a + b$
19. For what value of k will the equations $x + 2y + 7 = 0$, $2x + ky + 14 = 0$ represent coincident lines?
20. For what value of k , the following system of equations $2x + ky = 1$, $3x - 5y = 7$ has (i) a unique solution (ii) no solution

GRAPHICAL METHOD OF SOLUTION OF A PAIR OF LINEAR EQUATIONS

The graph of a pair of linear equations in two variables is represented by two lines.

1. If the lines intersect at a point, then that point gives the unique solution of the two equations. In this case, the pair of equations is **consistent**.

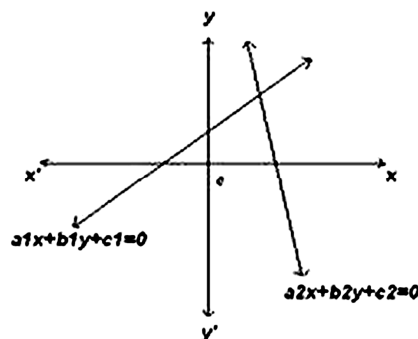

2. If the lines coincide, then there are infinitely many solutions — each point on the line being a solution. In this case, the pair of equations is **dependent (consistent)**.

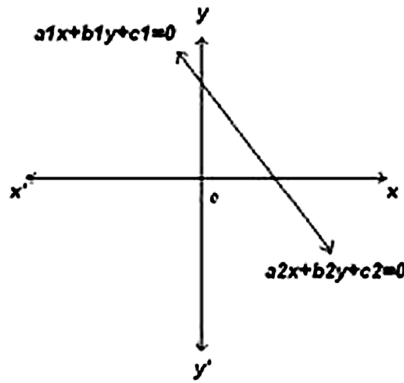

3. If the lines are parallel, then the pair of equations has no solution. In this case, the pair of equations is **inconsistent**.

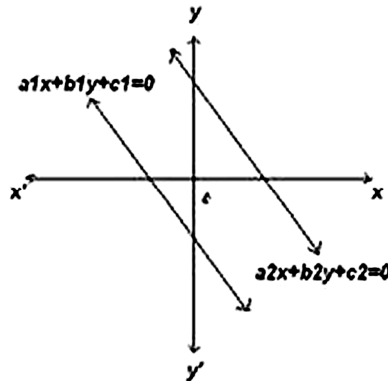

IMPORTANT QUESTIONS

Solve the equation graphically: $x + 3y = 6$ and $2x - 3y = 12$.

Solution: Given that

$$x + 3y = 6 \Rightarrow 3y = 6 - x \Rightarrow y = \frac{6 - x}{3}$$

x	0	3	6
y	2	1	0

and $2x - 3y = 12 \Rightarrow 3y = 2x - 12 \Rightarrow y = \frac{2x - 12}{3}$

x	0	3	6
y	-4	-2	0

Now plot the points and join the points to form the lines AB and PQ as shown in graph
 Since point B(6, 0) common to both the lines AB and PQ. Therefore, the solution of the pair of linear equations is $x = 6$ and $y = 0$

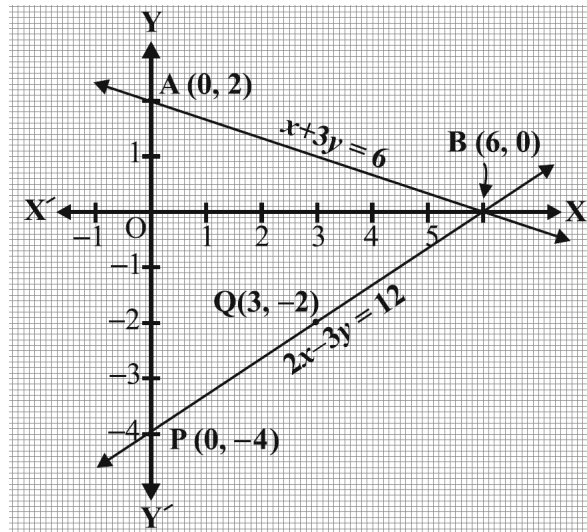

Questions for Practice

- Determine by drawing graphs, whether the following pair of linear equations has a unique solution or not: $3x + 4y = 12$; $y = 2$
- Determine by drawing graphs, whether the following pair of linear equations has a unique solution or not: $2x - 5 = 0$, $y + 4 = 0$.
- Draw the graphs of the equations $4x - y - 8 = 0$ and $2x - 3y + 6 = 0$.
 Also, determine the vertices of the triangle formed by the lines and x-axis.

4. Solve the following system of linear equations graphically: $3x - 2y - 1 = 0$; $2x - 3y + 6 = 0$.
Shade the region bounded by the lines and x-axis.
5. Solve graphically: $x + 4y = 10$, $y - 2 = 0$
6. Solve graphically: $2x - 3y = 6$, $x - 6 = 0$
7. Solve the following system of equations graphically: $3x - 5y + 1 = 0$, $2x - y + 3 = 0$.
Also find the points where the lines represented by the given equations intersect the x-axis.
8. Solve the following system of equations graphically: $x - 5y = 6$, $2x - 10y = 10$
Also find the points where the lines represented by the given equations intersect the x-axis.
9. Solve the following pair of linear equations graphically: $x + 3y = 6$; $2x - 3y = 12$
Also find the area of the triangle formed by the lines representing the given equations with y-axis.

MCQ QUESTIONS (1 mark)

1. The pair of equations $y = 0$ and $y = -7$ has
(a) one solution (b) two solution (c) infinitely many solutions (d) no solution
2. The pair of equations $x = a$ and $y = b$ graphically represents the lines which are
(a) parallel (b) intersecting at (a, b)
(c) coincident (d) intersecting at (b, a)
3. The value of c for which the pair of equations $cx - y = 2$ and $6x - 2y = 3$ will have no solution is
(a) 3 (b) -3 (c) -12 (d) no value
4. The pair of equations $5x - 15y = 8$ and $3x - 9y = 24/5$ has
(a) infinite number of solutions (b) unique solution
(c) no solution (d) one solution
5. The pair of equations $x + 2y + 5 = 0$ and $-3x - 6y + 1 = 0$ have
(a) infinite number of solutions (b) unique solution
(c) no solution (d) one solution
6. The sum of the digits of a two digit number is 9. If 27 is added to it, the digits of the numbers get reversed. The number is
(a) 36 (b) 72 (c) 63 (d) 25
7. The pair of equations $3x + 4y = 18$ and $4x + \frac{16}{3}y = 24$ has
(a) infinite number of solutions (b) unique solution
(c) no solution (d) cannot say anything
8. If the pair of equations $2x + 3y = 7$ and $kx + \frac{9}{2}y = 12$ have no solution, then the value of k is:
(a) $\frac{2}{3}$ (b) -3 (c) 3 (d) $\frac{3}{2}$
9. If $2x + 3y = 0$ and $4x - 3y = 0$, then $x + y$ equals:
(a) 0 (b) -1 (c) 1 (d) 2
10. If $31x + 43y = 117$ and $43 + 31y = 105$, then value of $x - y$ is:
(a) $\frac{1}{3}$ (b) -3 (c) 3 (d) $-\frac{1}{3}$
11. If $19x - 17y = 55$ and $17x - 19y = 53$, then the value of $x - y$ is:

- (a) $\frac{1}{3}$ (b) -3 (c) 3 (d) 5

12. If $(6, k)$ is a solution of the equation $3x + y - 22 = 0$, then the value of k is:

- (a) 4 (b) -4 (c) 3 (d) -3

13. If $3x + 2y = 13$ and $3x - 2y = 5$, then the value of $x + y$ is:

- (a) 5 (b) 3 (c) 7 (d) none of these

14. If the pair of equations $2x + 3y = 5$ and $5x + \frac{15}{2}y = k$ represent two coincident lines, then the value of k is:

- (a) -5 (b) $\frac{-25}{2}$ (c) $\frac{25}{2}$ (d) $\frac{-5}{2}$

CHAPTER – 4 QUADRATIC EQUATIONS

FACTORISATION METHODS TO FIND THE SOLUTION OF QUADRATIC EQUATIONS

Steps to find the solution of given quadratic equation by factorisation

- Firstly, write the given quadratic equation in standard form $ax^2 + bx + c = 0$.
- Find two numbers α and β such that sum of α and β is equal to b and product of α and β is equal to c .
- Write the middle term bx as $\alpha x + \beta x$ and factorise it by splitting the middle term and let factors are $(x + p)$ and $(x + q)$ i.e. $ax^2 + bx + c = 0 \Rightarrow (x + p)(x + q) = 0$
- Now equate each factor to zero and find the values of x .
- These values of x are the required roots/solutions of the given quadratic equation.

IMPORTANT QUESTIONS

Solve the quadratic equation by using factorization method: $x^2 + 2x - 8 = 0$

Solution: $x^2 + 2x - 8 = 0$

$$\Rightarrow x^2 + 4x - 2x - 8 = 0 \Rightarrow x(x + 4) - 2(x + 4) = 0$$

$$\Rightarrow (x + 4)(x - 2) = 0 \Rightarrow x + 4 = 0, x - 2 = 0 \Rightarrow x = -4, 2$$

Questions for practice

1. Solve the quadratic equation using factorization method: $x^2 + 7x - 18 = 0$
2. Solve the quadratic equation using factorization method: $x^2 + 5x - 6 = 0$
3. Solve the quadratic equation using factorization method: $y^2 - 4y + 3 = 0$
4. Solve the quadratic equation using factorization method: $x^2 - 21x + 108 = 0$
5. Solve the quadratic equation using factorization method: $x^2 - 11x - 80 = 0$
6. Solve the quadratic equation using factorization method: $x^2 - x - 156 = 0$
7. Solve the following for x : $\frac{1}{a+b+x} = \frac{1}{a} + \frac{1}{b} + \frac{1}{x}$.
8. Solve the following for x : $\frac{1}{2a+b+2x} = \frac{1}{2a} + \frac{1}{b} + \frac{1}{2x}$

NATURE OF ROOTS

The roots of the quadratic equation $ax^2 + bx + c = 0$ by quadratic formula are given by

$$x = \frac{-b \pm \sqrt{b^2 - 4ac}}{2a} = \frac{-b \pm \sqrt{D}}{2a}$$

where $D = b^2 - 4ac$ is called discriminant. The nature of roots depends upon the value of discriminant D . There are three cases –

Case – I

When $D > 0$ i.e. $b^2 - 4ac > 0$, then the quadratic equation has two distinct roots.

$$\text{i.e. } x = \frac{-b + \sqrt{D}}{2a} \text{ and } \frac{-b - \sqrt{D}}{2a}$$

Case – II

When $D = 0$, then the quadratic equation has two equal real roots.

$$\text{i.e. } x = \frac{-b}{2a} \text{ and } \frac{-b}{2a}$$

Case – III

When $D < 0$ then there is no real roots exist.

IMPORTANT QUESTIONS

Find the discriminant of the quadratic equation $2x^2 - 4x + 3 = 0$, and hence find the nature of its roots.

Solution : The given equation is of the form $ax^2 + bx + c = 0$, where $a = 2$, $b = -4$ and $c = 3$.

Therefore, the discriminant, $D = b^2 - 4ac = (-4)^2 - (4 \times 2 \times 3) = 16 - 24 = -8 < 0$

So, the given equation has no real roots.

Questions for Practice

1. Find the discriminant and the nature of the roots of quadratic equation: $3\sqrt{3}x^2 + 10x + \sqrt{3} = 0$.
2. Find discriminant and the nature of the roots of quadratic equation: $4x^2 - 2x + 3 = 0$.
3. Find discriminant and the nature of the roots of quadratic equation: $4x^2 - 12x + 9 = 0$.
4. Find discriminant and the nature of the roots of quadratic equation: $5x^2 + 5x + 6 = 0$.
5. Write the nature of roots of quadratic equation $4x^2 + 4\sqrt{3}x + 3 = 0$.
6. Write the nature of roots of the quadratic equation $9x^2 - 6x - 2 = 0$.
7. Write the nature of roots of quadratic equation : $4x^2 + 6x + 3 = 0$
8. The roots of $ax^2 + bx + c = 0$, $a \neq 0$ are real and unequal. What is value of D ?
9. If $ax^2 + bx + c = 0$ has equal roots, what is the value of c ?

QUADRATIC FORMULA METHOD

Steps to find the solution of given quadratic equation by quadratic formula method:

- Firstly, write the given quadratic equation in standard form $ax^2 + bx + c = 0$.
- Write the values of a , b and c by comparing the given equation with standard form.
- Find discriminant $D = b^2 - 4ac$. If value of D is negative, then is no real solution i.e. solution does not exist. If value of $D \geq 0$, then solution exists follow the next step.
- Put the value of a , b and D in quadratic formula $x = \frac{-b \pm \sqrt{D}}{2a}$ and get the required roots/solutions.

IMPORTANT QUESTIONS

Solve the quadratic equation by using quadratic formula: $x^2 + x - 6 = 0$

Solution: Here, $a = 1$, $b = 1$, $c = -6$

$$\Rightarrow D = b^2 - 4ac = 1 - 4(1)(-6) = 1 + 24 = 25 > 0$$

$$\text{Now, } x = \frac{-b \pm \sqrt{D}}{2a} = \frac{-1 \pm \sqrt{25}}{2(1)} = \frac{-1 \pm 5}{2} \Rightarrow x = \frac{-1-5}{2} \text{ or } \frac{-1+5}{2} \Rightarrow x = \frac{-6}{2} \text{ or } \frac{4}{2} \Rightarrow x = -3 \text{ or } 2$$

Questions for practice

1. Solve the quadratic equation by using quadratic formula: $x^2 - 7x + 18 = 0$

2. Solve the quadratic equation by using quadratic formula: $x^2 - 5x + 6 = 0$
3. Solve the quadratic equation by using quadratic formula: $y^2 + 4y + 3 = 0$
4. Solve the quadratic equation by using quadratic formula: $x^2 + 11x - 80 = 0$
5. Solve the quadratic equation by using quadratic formula: $x^2 + x - 156 = 0$
6. Solve for x by using quadratic formula : $9x^2 - 9(a + b)x + (2a^2 + 5ab + 2b^2) = 0$.

MCQ (1 MARK)

1. The roots of the equation $x^2 + 7x + 10 = 0$ are
 (a) 2 and 5 (b) -2 and 5 (c) -2 and -5 (d) 2 and -5
2. If α, β are the roots of the quadratic equation $x^2 + x + 1 = 0$, then $\frac{1}{\alpha} + \frac{1}{\beta}$
 (a) 0 (b) 1 (c) -1 (d) none of these
3. If the equation $x^2 + 4x + k = 0$ has real and distinct roots then
 (a) $k < 4$ (b) $k > 4$ (c) $k \leq 4$ (d) $k \geq 4$
4. If the equation $9x^2 + 6kx + 4 = 0$ has equal roots then the roots are both equal to
 (a) $\pm \frac{2}{3}$ (b) $\pm \frac{3}{2}$ (c) 0 (d) ± 3
5. If the equation $x^2 - bx + 1 = 0$ has two distinct roots then
 (a) $-3 < b < 3$ (b) $-2 < b < 2$ (c) $b > 2$ (d) $b < -2$
6. If $x = 1$ is a common root of the equations $ax^2 + ax + 3 = 0$ and $x^2 + x + b = 0$ then $ab =$
 (a) 6 (b) 3 (c) -3 (d) $\frac{7}{2}$
7. If p and q are the roots of the equation $x^2 - px + q = 0$, then
 (a) $p = 1, q = -2$ (b) $p = -2, q = 0$ (c) $b = 0, q = 1$ (d) $p = -2, q = 1$
8. If the equation $ax^2 + bx + c = 0$ has equal roots then $c =$
 (a) $\frac{-b}{2a}$ (b) $\frac{b}{2a}$ (c) $\frac{-b^2}{4a}$ (d) $\frac{b^2}{4a}$
9. If the equation $ax^2 + 2x + a = 0$ has two distinct roots if
 (a) $a = \pm 1$ (b) $a = 0$ (c) $a = 0, 1$ (d) $a = -1, 0$
10. Find the values of k for which the quadratic equation $2x^2 + kx + 3 = 0$ has real equal roots.
 (a) $\pm 2\sqrt{6}$ (b) $2\sqrt{6}$ (c) 0 (d) ± 2
11. Find the values of k for which the quadratic equation $kx(x - 3) + 9 = 0$ has real equal roots.
 (a) $k = 0$ or $k = 4$ (b) $k = 1$ or $k = 4$ (c) $k = -3$ or $k = 3$ (d) $k = -4$ or $k = 4$
12. Find the values of k for which the quadratic equation $4x^2 - 3kx + 1 = 0$ has real and equal roots.
 (a) $\pm \frac{4}{3}$ (b) $\pm \frac{2}{3}$ (c) ± 2 (d) none of these
13. The value of k for which equation $9x^2 + 8kx + 8 = 0$ has equal roots is:
 (a) only 3 (b) only -3 (c) ± 3 (d) 9

14. Which of the following is not a quadratic equation?

- (a) $x - \frac{3}{x} = 4$ (b) $3x - \frac{5}{x} = x^2$ (c) $x + \frac{1}{x} = 3$ (d) $x^2 - 3 = 4x^2 - 4x$

CHAPTER – 5 ARITHMETIC PROGRESSION

***n*th Term of an ARITHMETIC PROGRESSION (AP)**

*n*th term a_n of the AP with first term a and common difference d is given by

$$a_n = a + (n - 1) d.$$

IMPORTANT QUESTIONS

Find the 15th term of the 21, 24, 27, . . .

Solution: Here, $a = 21$, $d = 24 - 21 = 3$

We know that $a_n = a + (n - 1)d$

$$\text{So, } a_{15} = a + 14d = 21 + 14(3) = 21 + 42 = 63$$

Which term of the AP : 3, 9, 15, 21, . . . , is 99?

Solution: Here, $a = 3$, $d = 9 - 3 = 6$

We know that $a_n = a + (n - 1)d$

$$\text{Let } a_n = 99 \Rightarrow a + (n - 1)d = 99$$

$$\Rightarrow 3 + (n - 1)6 = 99 \Rightarrow (n - 1)6 = 99 - 3 = 96$$

$$\Rightarrow n - 1 = \frac{96}{6} = 16 \Rightarrow n = 16 + 1 = 17$$

Hence, 17th term of the given AP is 99

Determine the AP whose 3rd term is 5 and the 7th term is 9.

Solution: We have $a_3 = a + (3 - 1)d = a + 2d = 5$ (1)

and $a_7 = a + (7 - 1)d = a + 6d = 9$ (2)

Solving the pair of linear equations (1) and (2), we get $a = 3$, $d = 1$

Hence, the required AP is 3, 4, 5, 6, 7, . . .

Questions for practice

- Find the 10th term of the AP : 2, 7, 12, . . .
- Which term of the AP : 21, 18, 15, . . . is - 81?
- Which term of the AP : 3, 8, 13, 18, . . . , is 78?
- How many two-digit numbers are divisible by 3?
- How many three-digit numbers are divisible by 7?
- How many multiples of 4 lie between 10 and 250?
- Find the 31st term of an AP whose 11th term is 38 and the 16th term is 73.
- An AP consists of 50 terms of which 3rd term is 12 and the last term is 106. Find the 29th term.
- If the 3rd and the 9th terms of an AP are 4 and - 8 respectively, which term of this AP is zero?
- Which term of the AP : 3, 15, 27, 39, . . . will be 132 more than its 54th term?
- Determine the AP whose third term is 16 and the 7th term exceeds the 5th term by 12.
- The sum of 4th term and 8th term of an AP is 24 and the sum of 6th and 10th terms is 44. Find the AP.
- The sum of 5th term and 9th term of an AP is 72 and the sum of 7th and 12th terms is 97. Find the AP.

14. If the numbers $n - 2$, $4n - 1$ and $5n + 2$ are in AP, find the value of n .
15. Find the value of the middle most term (s) of the AP : $-11, -7, -3, \dots, 49$.
16. The sum of the first three terms of an AP is 33. If the product of the first and the third term exceeds the second term by 29, find the AP.
17. The sum of the 5th and the 7th terms of an AP is 52 and the 10th term is 46. Find the AP.
18. Find the 20th term of the AP whose 7th term is 24 less than the 11th term, first term being 12.
19. If the 9th term of an AP is zero, prove that its 29th term is twice its 19th term.
20. Which term of the AP: 53, 48, 43,... is the first negative term?
21. A sum of Rs 1000 is invested at 8% simple interest per year. Calculate the interest at the end of each year. Do these interests form an AP? If so, find the interest at the end of 30 years making use of this fact.
22. In a flower bed, there are 23 rose plants in the first row, 21 in the second, 19 in the third, and so on. There are 5 rose plants in the last row. How many rows are there in the flower bed?

n th Term from the end of an ARITHMETIC PROGRESSION (AP)

Let the last term of an AP be ' l ' and the common difference of an AP is ' d ' then the n th term from the end of an AP is given by

$$l_n = l - (n - 1) d.$$

IMPORTANT QUESTIONS

Find the 11th term from the last term (towards the first term) of the AP : 10, 7, 4, . . . , - 62.

Solution : Here, $a = 10$, $d = 7 - 10 = -3$, $l = -62$,

We know that n th term from the last is given by $l_n = l - (n - 1) d$.

$$\therefore l_{11} = l - 10d = -62 - 10(-3) = -62 + 30 = -32$$

Questions for practice

1. Find the 20th term from the last term of the AP : 3, 8, 13, . . . , 253.
2. Find the 10th term from the last term of the AP : 4, 9, 14, . . . , 254.
3. Find the 6th term from the end of the AP 17, 14, 11, (-40).
4. Find the 8th term from the end of the AP 7, 10, 13, 184.
5. Find the 10th term from the last term of the AP : 8, 10, 12, . . . , 126.

Sum of First n Terms of an ARITHMETIC PROGRESSION (AP)

The sum of the first n terms of an AP is given by

$$S_n = \frac{n}{2}[2a + (n-1)d]$$

where a = first term, d = common difference and n = number of terms.

or

$$S_n = \frac{n}{2}[a + l]$$

where l = last term

IMPORTANT QUESTIONS

Find the sum of the first 22 terms of the AP : 8, 3, -2, . . .

Solution : Here, $a = 8$, $d = 3 - 8 = -5$, $n = 22$.

We know that $S = \frac{n}{2}[2a + (n-1)d]$

$$\therefore S = \frac{22}{2}[16 + (22-1)(-5)] = 11(16 - 105) = 11(-89) = -979$$

So, the sum of the first 22 terms of the AP is -979 .

Questions for practice

1. If the sum of the first 14 terms of an AP is 1050 and its first term is 10, find the 20th term.
2. How many terms of the AP : 24, 21, 18, . . . must be taken so that their sum is 78?
3. How many terms of the AP : 9, 17, 25, . . . must be taken to give a sum of 636?
4. Find the sum of first 24 terms of the list of numbers whose n th term is given by $a_n = 3 + 2n$
5. Find the sum of the first 40 positive integers divisible by 6.
6. Find the sum of the first 15 multiples of 8.
7. Find the sum of the odd numbers between 0 and 50.
8. The first term of an AP is 5, the last term is 45 and the sum is 400. Find the number of terms and the common difference.
9. The first and the last terms of an AP are 17 and 350 respectively. If the common difference is 9, how many terms are there and what is their sum?
10. Find the sum of first 22 terms of an AP in which $d = 7$ and 22nd term is 149.
11. Find the sum of first 51 terms of an AP whose second and third terms are 14 and 18 respectively.
12. If the sum of first 7 terms of an AP is 49 and that of 17 terms is 289, find the sum of first n terms.
13. If $a_n = 3 - 4n$, show that a_1, a_2, a_3, \dots form an AP. Also find S_{20} .
14. In an AP, if $S_n = n(4n + 1)$, find the AP.
15. In an AP, if $S_n = 3n^2 + 5n$ and $a_k = 164$, find the value of k .
16. Show that $a_1, a_2, \dots, a_n, \dots$ form an AP where a_n is defined as : (i) $a_n = 3 + 4n$ (ii) $a_n = 9 - 5n$
Also find the sum of the first 15 terms in each case.
17. If the sum of the first n terms of an AP is $4n - n^2$, what is the first term (that is S_1)? What is the sum of first two terms? What is the second term? Similarly, find the 3rd, the 10th and the n th terms.
18. Find the sum of first 17 terms of an AP whose 4th and 9th terms are -15 and -30 respectively.
19. If sum of first 6 terms of an AP is 36 and that of the first 16 terms is 256, find the sum of first 10 terms.
20. Find the sum of all the 11 terms of an AP whose middle most term is 30.
21. Find the sum of last ten terms of the AP: 8, 10, 12, ---, 126.
22. How many terms of the AP: $-15, -13, -11, \dots$ are needed to make the sum -55 ? Explain the reason for double answer.

MCQ QUESTIONS (1 mark)

1. The 10th term of the AP: 5, 8, 11, 14, ... is
(a) 32 (b) 35 (c) 38 (d) 185
2. In an AP if $a = -7.2$, $d = 3.6$, $a_n = 7.2$, then n is
(a) 1 (b) 3 (c) 4 (d) 5
3. In an AP, if $d = -4$, $n = 7$, $a_n = 4$, then a is
(a) 6 (b) 7 (c) 20 (d) 28
4. In an AP, if $a = 3.5$, $d = 0$, $n = 101$, then a_n will be
(a) 0 (b) 3.5 (c) 103.5 (d) 104.5
5. The list of numbers $-10, -6, -2, 2, \dots$ is
(a) an AP with $d = -16$ (b) an AP with $d = 4$
(c) an AP with $d = -4$ (d) not an AP

6. The 11th term of the AP: $-5, -5/2, 0, 5/2, \dots$ is
(a) -20 (b) 20 (c) -30 (d) 30
7. The first four terms of an AP, whose first term is -2 and the common difference is -2 , are
(a) $-2, 0, 2, 4$ (b) $-2, 4, -8, 16$ (c) $-2, -4, -6, -8$ (d) $-2, -4, -8, -16$
8. The 21st term of the AP whose first two terms are -3 and 4 is
(a) 17 (b) 137 (c) 143 (d) -143
9. If the 2nd term of an AP is 13 and the 5th term is 25 , what is its 7th term?
(a) 30 (b) 33 (c) 37 (d) 38
10. Which term of the AP: $21, 42, 63, 84, \dots$ is 210 ?
(a) 9th (b) 10th (c) 11th (d) 12th
11. If the common difference of an AP is 5 , then what is $a_{18} - a_{13}$?
(a) 5 (b) 20 (c) 25 (d) 30
12. What is the common difference of an AP in which $a_{18} - a_{14} = 32$?
(a) 8 (b) -8 (c) -4 (d) 4
13. Two APs have the same common difference. The first term of one of these is -1 and that of the other is -8 . Then the difference between their 4th terms is
(a) -1 (b) -8 (c) 7 (d) -9
14. If 7 times the 7th term of an AP is equal to 11 times its 11th term, then its 18th term will be
(a) 7 (b) 11 (c) 18 (d) 0
15. The 4th term from the end of the AP: $-11, -8, -5, \dots, 49$ is
(a) 37 (b) 40 (c) 43 (d) 58
16. If the first term of an AP is -5 and the common difference is 2 , then the sum of the first 6 terms is
(a) 0 (b) 5 (c) 6 (d) 15
17. The sum of first 16 terms of the AP: $10, 6, 2, \dots$ is
(a) -320 (b) 320 (c) -352 (d) -400
18. In an AP if $a = 1$, $a_n = 20$ and $S_n = 399$, then n is
(a) 19 (b) 21 (c) 38 (d) 42
19. The sum of first 100 multiples of 3 is
(a) 30300 (b) 15150 (c) 300 (d) none of these
20. The sum of first five multiples of 3 is
(a) 45 (b) 55 (c) 65 (d) 75

CHAPTER – 6 TRIANGLES

IMPORTANT THEOREMS

BASIC PROPORTIONALITY THEOREM OR THALES THEOREM

If a straight line is drawn parallel to one side of a triangle intersecting the other two sides, then it divides the two sides in the same ratio.

GIVEN: A ΔABC and line 'l' parallel to BC intersect AB at D and AC at E.

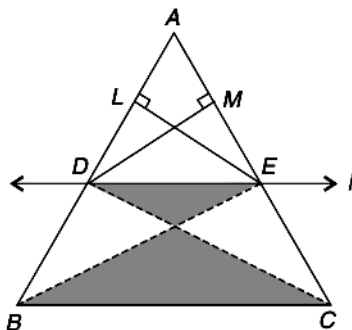

TO PROVE :

$$\frac{AD}{DB} = \frac{AE}{EC}$$

CONSTRUCTION : Join BE and CD. Draw $EL \perp$ to AB and $DM \perp$ AC.

PROOF: We know that areas of the triangles on the same base and between same parallel lines are equal, hence we have :

$$\text{area} (\Delta BDE) = \text{area} (\Delta CDE) \quad \dots\text{(i)}$$

Now, we have

$$\frac{\text{Area of } \Delta ADE}{\text{Area of } \Delta BDE} = \frac{\frac{1}{2} \times AD \times EL}{\frac{1}{2} \times DB \times EL} = \frac{AD}{DB} \quad \dots\text{(ii)}$$

Again, we have

$$\frac{\text{Area of } \Delta ADE}{\text{Area of } \Delta CDE} = \frac{\frac{1}{2} \times AE \times DM}{\frac{1}{2} \times EC \times DM} = \frac{AE}{EC} \quad \dots\text{(iii)}$$

Put value from (i) in (ii), we have

$$\frac{\text{Area of } \Delta ADE}{\text{Area of } \Delta CDE} = \frac{AD}{DB} \quad \dots\text{(iv)}$$

On comparing equation (ii) and (iii), we get

$$\frac{AD}{DB} = \frac{AE}{EC} \quad \text{Hence Proved.}$$

COROLLARY :

$$\text{(i)} \quad \frac{AB}{DB} = \frac{AC}{EC}$$

$$\text{(ii)} \quad \frac{DB}{AD} = \frac{EC}{AE}$$

$$\text{(iii)} \quad \frac{AB}{AD} = \frac{AC}{AE}$$

$$\text{(iv)} \quad \frac{DB}{AB} = \frac{EC}{AC}$$

$$\text{(v)} \quad \frac{AD}{AB} = \frac{AE}{AC}$$

CONVERSE OF BASIC PROPORTIONALITY THEOREM (CONVERSE OF THALES THEOREM)

If a straight line divides any two sides of a triangle in the same ratio, then the line must be parallel to the third side.

GIVEN : A ΔABC and line 'l' intersecting the sides AB at D and AC at E such that :

$$\frac{AD}{DB} = \frac{AE}{EC}$$

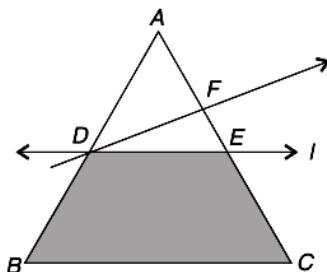

TO PROVE : $l \parallel BC$.

PROOF : Let us suppose that the line l is not parallel to BC .

Then through D , there must be any other line which must be parallel to BC .

Let $DF \parallel BC$, such that $E \neq F$.

Since,

$$DF \parallel BC \quad \text{(by supposition)}$$

$$\frac{AD}{DB} = \frac{AF}{FC} \quad \dots(i) \text{ (Basic Proportionality Theorem)}$$

$$\frac{AD}{DB} = \frac{AE}{EC} \quad \dots(ii) \quad \text{(Given)}$$

Comparing (i) and (ii), we get

$$\frac{AF}{FC} = \frac{AE}{EC}$$

Adding 1 to both sides, we get

$$\frac{AF}{FC} + 1 = \frac{AE}{EC} + 1$$

$$\Rightarrow \frac{AF + FC}{FC} = \frac{AE + EC}{EC}$$

$$\Rightarrow \frac{AC}{FC} = \frac{AC}{EC}$$

$$\Rightarrow \frac{1}{FC} = \frac{1}{EC}$$

$$\Rightarrow FC = EC$$

This shows that E and F must coincide, but it contradicts our supposition that $E \neq F$ and $DF \parallel BC$.

Hence, there is one and only line, $DE \parallel BC$, i.e.

$$\boxed{l \parallel BC}$$

Hence Proved.

Exercise 6.2 Important Questions

1. If a line intersects sides AB and AC of a ΔABC at D and E respectively and is parallel to BC , prove that $AD/AB = AE/AC$
2. $ABCD$ is a trapezium with $AB \parallel DC$. E and F are points on non-parallel sides AD and BC respectively such that EF is parallel to AB . Show that $AE/ED = BF/FC$

3. In the below figure, $PS/SQ = PT/TR$ and $\angle PST = \angle PRQ$. Prove that PQR is an isosceles triangle.

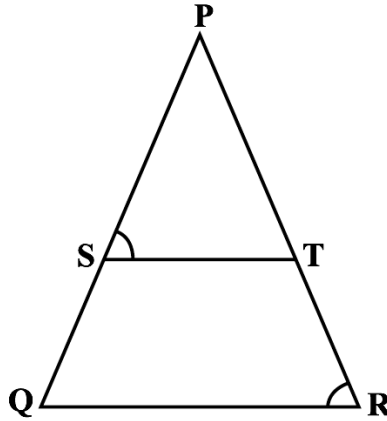

4. In the below figure, if $LM \parallel CB$ and $LN \parallel CD$, prove that $AM/AB = AN/AD$

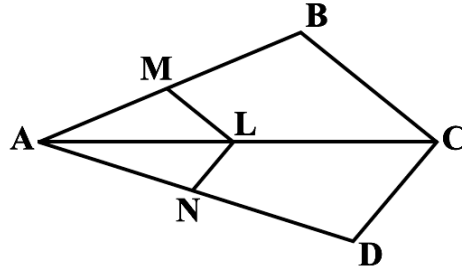

5. In the below figure, $DE \parallel AC$ and $DF \parallel AE$. Prove that $BF/FE = BE/EC$

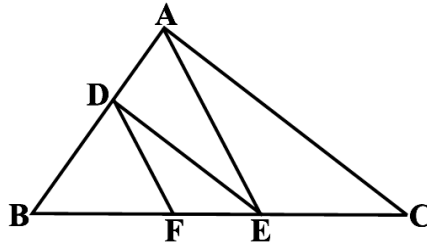

6. In the below figure, $DE \parallel OQ$ and $DF \parallel OR$. Show that $EF \parallel QR$.

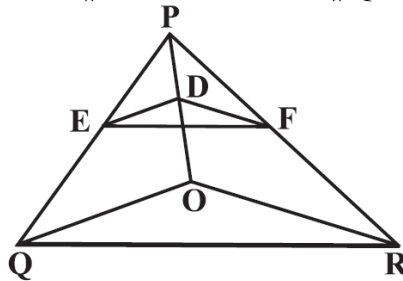

7. In the below figure, A, B and C are points on OP, OQ and OR respectively such that $AB \parallel PQ$ and $AC \parallel PR$. Show that $BC \parallel QR$.

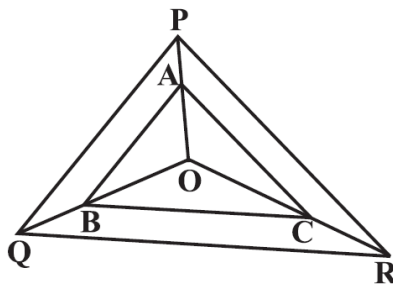

- ABCD is a trapezium in which $AB \parallel DC$ and its diagonals intersect each other at the point O. Show that $AO/BO = CO/DO$
- The diagonals of a quadrilateral ABCD intersect each other at the point O such that $AO/BO = CO/DO$. Show that ABCD is a trapezium.

Exercise 6.3 Important Questions

- A girl of height 90 cm is walking away from the base of a lamp-post at a speed of 1.2 m/s. If the lamp is 3.6 m above the ground, find the length of her shadow after 4 seconds.
- In the below figure, $QR/QS = QT/PR$ and $\angle 1 = \angle 2$. Show that $\Delta PQS \sim \Delta TQR$.

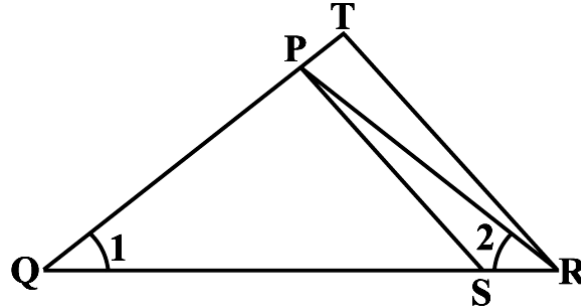

- S and T are points on sides PR and QR of ΔPQR such that $\angle P = \angle RTS$. Show that $\Delta RPQ \sim \Delta RTS$.
- In the below figure, if $\Delta ABE \cong \Delta ACD$, show that $\Delta ADE \sim \Delta ABC$.

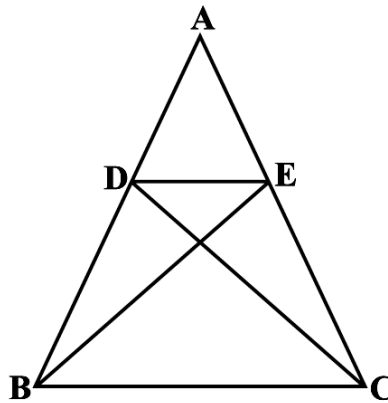

- In the below figure, altitudes AD and CE of ΔABC intersect each other at the point P. Show that: (i) $\Delta AEP \sim \Delta CDP$ (ii) $\Delta ABD \sim \Delta CBE$ (iii) $\Delta AEP \sim \Delta ADB$ (iv) $\Delta PDC \sim \Delta BEC$

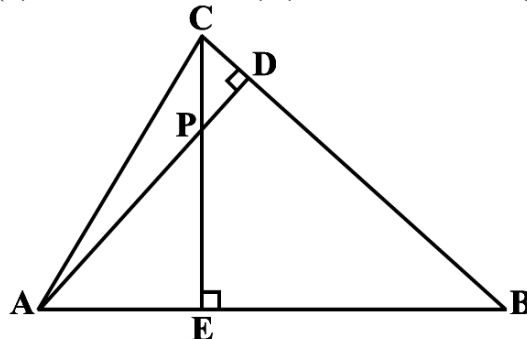

- E is a point on the side AD produced of a parallelogram ABCD and BE intersects CD at F. Show that $\Delta ABE \sim \Delta CFB$.
- In the below figure, ABC and AMP are two right triangles, right angled at B and M respectively. Prove that: (i) $\Delta ABC \sim \Delta AMP$ (ii) $CA/PA = BC/MP$

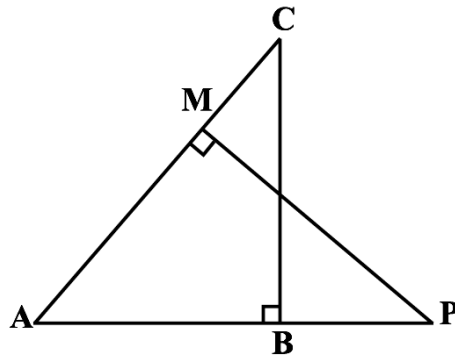

8. Sides AB and BC and median AD of a triangle ABC are respectively proportional to sides PQ and QR and median PM of ΔPQR . Show that $\Delta ABC \sim \Delta PQR$.
9. D is a point on the side BC of a triangle ABC such that $\angle ADC = \angle BAC$. Show that $CA^2 = CB \cdot CD$.
10. Sides AB and AC and median AD of a triangle ABC are respectively proportional to sides PQ and PR and median PM of another triangle PQR. Show that $\Delta ABC \sim \Delta PQR$.
11. A vertical pole of length 6 m casts a shadow 4 m long on the ground and at the same time a tower casts a shadow 28 m long. Find the height of the tower.
12. If AD and PM are medians of triangles ABC and PQR, respectively where $\Delta ABC \sim \Delta PQR$, prove that $AB/PQ = AD/PM$.

MCQ QUESTIONS (1 mark)

1. The lengths of the diagonals of a rhombus are 16 cm and 12 cm. Then, the length of the side of the rhombus is
(a) 9 cm (b) 10 cm (c) 8 cm (d) 20 cm
2. In triangles ABC and DEF, $\angle B = \angle E$, $\angle F = \angle C$ and $AB = 3 DE$. Then, the two triangles are
(a) congruent but not similar (b) similar but not congruent
(c) neither congruent nor similar (d) congruent as well as similar
3. If $\Delta ABC \sim \Delta QRP$, $\frac{ar(ABC)}{ar(PQR)} = \frac{9}{4}$, $AB = 18$ cm and $BC = 15$ cm, then PR is equal to
(a) 10 cm (b) 12 cm (c) $20/3$ cm (d) 8 cm
4. If S is a point on side PQ of a ΔPQR such that $PS = QS = RS$, then
(a) $PR \cdot QR = RS^2$ (b) $QS^2 + RS^2 = QR^2$
(c) $PR^2 + QR^2 = PQ^2$ (d) $PS^2 + RS^2 = PR^2$
5. A vertical pole of length 20 m casts a shadow 10 m long on the ground and at the same time a tower casts a shadow 50 m long, then the height of the tower.
(a) 100 m (b) 120 m (c) 25 m (d) none of these
6. The areas of two similar triangles are in the ratio 4 : 9. The corresponding sides of these triangles are in the ratio
(a) 2 : 3 (b) 4 : 9 (c) 81 : 16 (d) 16 : 81
7. The areas of two similar triangles are in respectively 9 cm^2 and 16 cm^2 . The ratio of their corresponding sides is

(a) 2 : 3 (b) 3 : 4 (c) 4 : 3 (d) 4 : 5

8. Two isosceles triangles have equal angles and their areas are in the ratio 16 : 25. The ratio of their corresponding heights is

(a) 3 : 2 (b) 5 : 4 (c) 5 : 7 (d) 4 : 5

9. If $\triangle ABC$ and $\triangle DEF$ are similar such that $2AB = DE$ and $BC = 8$ cm, then $EF =$

(a) 16 cm (b) 112 cm (c) 8 cm (d) 4 cm

10. XY is drawn parallel to the base BC of a $\triangle ABC$ cutting AB at X and AC at Y . If $AB = 4BX$ and $YC = 2$ cm, then $AY =$

(a) 2 cm (b) 6 cm (c) 8 cm (d) 4 cm

11. Two poles of height 6 m and 11 m stand vertically upright on a plane ground. If the distance between their foot is 12 m, the distance between their tops is

(a) 14 cm (b) 12 cm (c) 13 cm (d) 11 cm

12. In triangles ABC and DEF , $\angle A = \angle E = 40^\circ$, $AB : ED = AC : EF$ and $\angle F = 65^\circ$, then $\angle B =$

(a) 35° (b) 65° (c) 75° (d) 85°

13. If ABC and DEF are similar triangles such that $\angle A = 47^\circ$ and $\angle E = 83^\circ$, then $\angle C =$

(a) 50° (b) 60° (c) 70° (d) 80°

CHAPTER – 7 COORDINATE GEOMETRY

DISTANCE FORMULA

The distance between any two points $A(x_1, y_1)$ and $B(x_2, y_2)$ is given by

$$AB = \sqrt{(x_2 - x_1)^2 + (y_2 - y_1)^2}$$

$$\text{or } AB = \sqrt{(\text{difference of abscissae})^2 + (\text{difference of ordinates})^2}$$

Distance of a point from origin

The distance of a point $P(x, y)$ from origin O is given by $OP = \sqrt{x^2 + y^2}$

Problems based on geometrical figure

To show that a given figure is a

- ☞ Parallelogram – prove that the opposite sides are equal
- ☞ Rectangle – prove that the opposite sides are equal and the diagonals are equal.
- ☞ Parallelogram but not rectangle – prove that the opposite sides are equal and the diagonals are not equal.
- ☞ Rhombus – prove that the four sides are equal
- ☞ Square – prove that the four sides are equal and the diagonals are equal.
- ☞ Rhombus but not square – prove that the four sides are equal and the diagonals are not equal.
- ☞ Isosceles triangle – prove any two sides are equal.
- ☞ Equilateral triangle – prove that all three sides are equal.
- ☞ Right triangle – prove that sides of triangle satisfies Pythagoras theorem.

IMPORTANT QUESTIONS

Show that the points (1, 7), (4, 2), (-1, -1) and (-4, 4) are the vertices of a square.

Solution : Let A(1, 7), B(4, 2), C(-1, -1) and D(-4, 4) be the given points.

$$AB = \sqrt{(1-4)^2 + (7-2)^2} = \sqrt{9+25} = \sqrt{34}$$

$$BC = \sqrt{(4+1)^2 + (2+1)^2} = \sqrt{25+9} = \sqrt{34}$$

$$CD = \sqrt{(-1+4)^2 + (-1-4)^2} = \sqrt{9+25} = \sqrt{34}$$

$$DA = \sqrt{(1+4)^2 + (7-4)^2} = \sqrt{25+9} = \sqrt{34}$$

$$AC = \sqrt{(1+1)^2 + (7+1)^2} = \sqrt{4+64} = \sqrt{68}$$

$$BD = \sqrt{(4+4)^2 + (2-4)^2} = \sqrt{64+4} = \sqrt{68}$$

Since, $AB = BC = CD = DA$ and $AC = BD$, all the four sides of the quadrilateral ABCD are equal and its diagonals AC and BD are also equal. Therefore, ABCD is a square.

Find a point on the y-axis which is equidistant from the points A(6, 5) and B(-4, 3).

Solution : We know that a point on the y-axis is of the form (0, y). So, let the point P(0, y) be equidistant from A and B. Then $AP^2 = BP^2$

$$\Rightarrow (6-0)^2 + (5-y)^2 = (-4-0)^2 + (3-y)^2$$

$$\Rightarrow 36 + 25 + y^2 - 10y = 16 + 9 + y^2 - 6y \Rightarrow 4y = 36 \Rightarrow y = 9$$

So, the required point is (0, 9).

Questions for practice

1. Show that the points A(1, 2), B(5, 4), C(3, 8) and D(-1, 6) are vertices of a square.
2. Show that the points A(5, 6), B(1, 5), C(2, 1) and D(6, 2) are vertices of a square.
3. Show that the points A(1, -3), B(13, 9), C(10, 12) and D(-2, 0) are vertices of a rectangle.
4. Show that the points A(1, 0), B(5, 3), C(2, 7) and D(-2, 4) are vertices of a rhombus.
5. Prove that the points A(-2, -1), B(1, 0), C(4, 3) and D(1, 2) are vertices of a parallelogram.
6. Find the point on x-axis which is equidistant from (7, 6) and (-3, 4).
7. Find the point on the x-axis which is equidistant from (2, -5) and (-2, 9).
8. Find a point on the y-axis which is equidistant from the points A(5, 2) and B(-4, 3).
9. Find a point on the y-axis which is equidistant from the points A(5, -2) and B(-3, 2).
10. Find the values of y for which the distance between the points P(2, -3) and Q(10, y) is 10 units.
11. Find the value of a, if the distance between the points A (-3, -14) and B (a, -5) is 9 units.
12. If the point A (2, -4) is equidistant from P (3, 8) and Q (-10, y), find the values of y. Also find distance PQ.

Section formula

The coordinates of the point P(x, y) which divides the line segment joining the points A(x₁, y₁) and B(x₂, y₂), internally, in the ratio $m_1 : m_2$ are

$$\left(\frac{m_1x_2 + m_2x_1}{m_1 + m_2}, \frac{m_1y_2 + m_2y_1}{m_1 + m_2} \right)$$

Mid-point formula

The coordinates of the point P(x, y) which is the midpoint of the line segment joining the points

$$A(x_1, y_1) \text{ and } B(x_2, y_2), \text{ are } \left(\frac{x_1 + x_2}{2}, \frac{y_1 + y_2}{2} \right)$$

IMPORTANT QUESTIONS

Find the coordinates of the point which divides the line segment joining the points (4, - 3) and (8, 5) in the ratio 3 : 1 internally.

Solution : Let P(x, y) be the required point.

Using the section formula, $x = \frac{m_2x_1 + m_1x_2}{m_1 + m_2}$, $y = \frac{m_2y_1 + m_1y_2}{m_1 + m_2}$ we get

$$x = \frac{3(8) + 1(4)}{3 + 1} = 7, y = \frac{3(5) + 1(-3)}{3 + 1} = 3$$

Therefore, (7, 3) is the required point.

In what ratio does the point (- 4, 6) divide the line segment joining the points A(- 6, 10) and B(3, - 8)?

Solution : Let (- 4, 6) divide AB internally in the ratio k : 1.

Using the section formula, $x = \frac{m_2x_1 + m_1x_2}{m_1 + m_2}$, $y = \frac{m_2y_1 + m_1y_2}{m_1 + m_2}$ we get

$$y = \frac{k(-8) + 1(10)}{k + 1} = 6$$

$$\Rightarrow -8k + 10 = 6k + 6 \Rightarrow -8k - 6k = 6 - 10$$

$$\Rightarrow -14k = -4 \Rightarrow k = \frac{4}{14} = \frac{2}{7}$$

Therefore, the point (- 4, 6) divides the line segment joining the points A(- 6, 10) and B(3, - 8) in the ratio 2 : 7.

Questions for practice

1. Find the coordinates of the point which divides the join of (-1, 7) and (4, -3) in the ratio 2 : 3.
2. Find the coordinates of the points of trisection of the line segment joining (4, -1) and (-2, -3).
3. Find the coordinates of the points of trisection (i.e., points dividing in three equal parts) of the line segment joining the points A(2, - 2) and B(- 7, 4).
4. Find the ratio in which the y-axis divides the line segment joining the points (5, - 6) and (-1, - 4). Also find the point of intersection.
5. Find the ratio in which the line segment joining the points (- 3, 10) and (6, - 8) is divided by (- 1, 6).
6. Find the ratio in which the line segment joining A(1, - 5) and B(- 4, 5) is divided by the x-axis. Also find the coordinates of the point of division.
7. Find the coordinates of the points which divide the line segment joining A(- 2, 2) and B(2, 8) into four equal parts.
8. If the points A(6, 1), B(8, 2), C(9, 4) and D(p, 3) are the vertices of a parallelogram, taken in order, find the value of p.
9. If (1, 2), (4, y), (x, 6) and (3, 5) are the vertices of a parallelogram taken in order, find x and y.
10. In what ratio does the x-axis divide the line segment joining the points (- 4, - 6) and (-1, 7)? Find the coordinates of the point of division.
11. If P (9a - 2, -b) divides line segment joining A (3a + 1, -3) and B (8a, 5) in the ratio 3 : 1, find the values of a and b.
12. If (a, b) is the mid-point of the line segment joining the points A (10, -6) and B (k, 4) and a - 2b = 18, find the value of k and the distance AB.
13. The centre of a circle is (2a, a - 7). Find the values of a if the circle passes through the point (11, -9) and has diameter $10\sqrt{2}$ units.
14. The line segment joining the points A (3, 2) and B (5, 1) is divided at the point P in the ratio 1:2 and it lies on the line $3x - 18y + k = 0$. Find the value of k.

15. Find the coordinates of the point R on the line segment joining the points P (-1, 3) and Q (2, 5) such that $PR = \frac{3}{5}PQ$.
16. Find the values of k if the points A (k + 1, 2k), B (3k, 2k + 3) and C (5k - 1, 5k) are collinear.
17. Find the ratio in which the line $2x + 3y - 5 = 0$ divides the line segment joining the points (8, -9) and (2, 1). Also find the coordinates of the point of division.
18. The mid-points D, E, F of the sides of a triangle ABC are (3, 4), (8, 9) and (6, 7). Find the coordinates of the vertices of the triangle.

MCQ (1 MARK)

- The distance of the point P(4, -3) from the origin is
(a) 1 unit (b) 7 units (c) 5 units (d) 3 units
- The distance between the points A(2, -3) and B(2, 2) is
(a) 2 units (b) 4 units (c) 5 units (d) 3 units
- What is the midpoint of a line with endpoints (-3, 4) and (10, -5)?
(a) (-13, -9) (b) (-6.5, -4.5) (c) (3.5, -0.5) (d) none of these
- If the distance between the points (8, p) and (4, 3) is 5 then value of p is
(a) 6 (b) 0 (c) both (a) and (b) (d) none of these
- If the origin is the mid-point of the line segment joined by the points (2,3) and (x,y), then the value of (x,y) is
(a) (2, -3) (b) (2, 3) (c) (-2, 3) (d) (-2, -3)
- The distance of the point P(2, 3) from the x-axis is:
(a) 2 (b) 3 (c) 1 (d) 5
- The distance between the points A(0, 6) and B(0, -2) is:
(a) 2 (b) 6 (c) 4 (d) 8
- The distance of the point P(-6, 8) from the origin is:
(a) 8 (b) 27 (c) 10 (d) 6
- The distance between the points (0, 5) and (-5, 0) is:
(a) 5 (b) 52 (c) 25 (d) 10
- AOBC is a rectangle whose three vertices are A(0, 3), O(0, 0) and B(5, 0). The length of its diagonal is:
(a) 5 (b) 3 (c) 34 (d) 4
- The perimeter of a triangle with vertices (0, 4), (0, 0) and (3, 0) is:
(a) 5 (b) 12 (c) 11 (d) 7 + 5
- The points (-4, 0), (4, 0), (0, 3) are the vertices of a :
(a) Right triangle (b) Isosceles triangle (c) Equilateral triangle (d) Scalene triangle
- Point on x - axis has coordinates:
(a) (a, 0) (b) (0, a) (c) (-a, a) (d) (a, -a)

14. Point on y – axis has coordinates:

(a) $(-a, b)$

(b) $(a, 0)$

(c) $(0, b)$

(d) $(-a, -b)$

CHAPTER – 8 & 9 TRIGONOMETRY

Trigonometric Ratios (T - Ratios) of an acute angle of a right triangle

In XOY-plane, let a revolving line OP starting from OX, trace out $\angle XOP = \theta$. From P (x, y) draw $PM \perp$ to OX.

In right angled triangle OMP. $OM = x$ (Adjacent side); $PM = y$ (opposite side); $OP = r$ (hypotenuse).

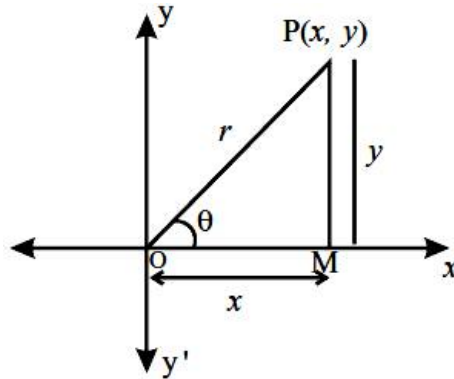

$$\sin \theta = \frac{\text{Opposite Side}}{\text{Hypotenuse}} = \frac{y}{r}, \quad \cos \theta = \frac{\text{Adjacent Side}}{\text{Hypotenuse}} = \frac{x}{r}, \quad \tan \theta = \frac{\text{Opposite Side}}{\text{Adjacent Side}} = \frac{y}{x}$$

$$\operatorname{cosec} \theta = \frac{\text{Hypotenuse}}{\text{Opposite Side}} = \frac{r}{y}, \quad \sec \theta = \frac{\text{Hypotenuse}}{\text{Adjacent Side}} = \frac{r}{x}, \quad \cot \theta = \frac{\text{Adjacent Side}}{\text{Opposite Side}} = \frac{x}{y}$$

Reciprocal Relations

$$\operatorname{cosec} \theta = \frac{1}{\sin \theta}, \quad \sec \theta = \frac{1}{\cos \theta} \quad \text{and} \quad \cot \theta = \frac{1}{\tan \theta}$$

Quotient Relations

$$\tan \theta = \frac{\sin \theta}{\cos \theta} \quad \text{and} \quad \cot \theta = \frac{\cos \theta}{\sin \theta}$$

IMPORTANT QUESTIONS

If $\tan A = \frac{4}{3}$, find the value of all T- ratios of θ .

Solution: Given that, In right ΔABC , $\tan A = \frac{BC}{AB} = \frac{4}{3}$

Therefore, if $BC = 4k$, then $AB = 3k$, where k is a positive number.

Now, by using the Pythagoras Theorem, we have

$$AC^2 = AB^2 + BC^2 = (4k)^2 + (3k)^2 = 25k^2$$

So, $AC = 5k$

Now, we can write all the trigonometric ratios using their definition

$$\sin A = \frac{BC}{AC} = \frac{4k}{5k} = \frac{4}{5}, \quad \cos A = \frac{AB}{AC} = \frac{3k}{5k} = \frac{3}{5}$$

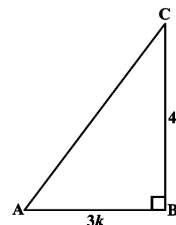

$$\text{and } \cot A = \frac{1}{\tan A} = \frac{3}{4},$$

$$\operatorname{cosec} A = \frac{1}{\sin A} = \frac{5}{4},$$

$$\sec A = \frac{1}{\cos A} = \frac{5}{3}$$

Questions for Practice

1. If $\sin \theta = \frac{5}{13}$, find the value of all T-ratios of θ .
2. If $\cos \theta = \frac{7}{25}$, find the value of all T-ratios of θ .
3. If $\tan \theta = \frac{15}{8}$, find the value of all T-ratios of θ .
4. If $\cot \theta = 2$, find the value of all T-ratios of θ .
5. If $\operatorname{cosec} \theta = \sqrt{10}$, find the value of all T-ratios of θ .
6. In ΔOPQ , right-angled at P, $OP = 7$ cm and $OQ - PQ = 1$ cm. Determine the values of $\sin Q$ and $\cos Q$.
7. In ΔPQR , right-angled at Q, $PR + QR = 25$ cm and $PQ = 5$ cm. Determine the values of $\sin P$, $\cos P$ and $\tan P$.

Trigonometric ratios for angle of measure.

$0^\circ, 30^\circ, 45^\circ, 60^\circ$ and 90° in tabular form.

$\angle A$	0°	30°	45°	60°	90°
sinA	0	$\frac{1}{2}$	$\frac{1}{\sqrt{2}}$	$\frac{\sqrt{3}}{2}$	1
cosA	1	$\frac{\sqrt{3}}{2}$	$\frac{1}{\sqrt{2}}$	$\frac{1}{2}$	0
tanA	0	$\frac{1}{\sqrt{3}}$	1	$\sqrt{3}$	Not defined
cosecA	Not defined	2	$\sqrt{2}$	$\frac{2}{\sqrt{3}}$	1
secA	1	$\frac{2}{\sqrt{3}}$	$\sqrt{2}$	2	Not defined
cotA	Not defined	$\sqrt{3}$	1	$\frac{1}{\sqrt{3}}$	0

IMPORTANT QUESTIONS

If $\cos(A - B) = \frac{\sqrt{3}}{2}$ and $\sin(A + B) = 1$, then find the value of A and B.

Solution: Given that $\cos(A - B) = \frac{\sqrt{3}}{2} = \cos 30^\circ$

$$\Rightarrow A - B = 30^\circ \dots\dots\dots (1)$$

$$\text{and } \sin(A + B) = 1 = \sin 90^\circ$$

$$\Rightarrow A + B = 90^\circ \dots\dots\dots (2)$$

Solving equations (1) and (2), we get $A = 60^\circ$ and $B = 30^\circ$.

Questions for Practice

Evaluate each of the following:

1. $\sin 60^\circ \cos 30^\circ + \cos 60^\circ \sin 30^\circ$
2. $\cos 60^\circ \cos 30^\circ - \sin 60^\circ \sin 30^\circ$
3. $\cos 45^\circ \cos 30^\circ + \sin 45^\circ \sin 30^\circ$
4. $\sin 60^\circ \sin 45^\circ - \cos 60^\circ \cos 45^\circ$
5. $(\sin^2 30^\circ + 4 \cot^2 45^\circ - \sec^2 60^\circ)(\operatorname{cosec}^2 45^\circ \sec^2 30^\circ)$
6. If $\sin(A - B) = \frac{1}{2}$ and $\cos(A + B) = \frac{1}{2}$, then find the value of A and B.
7. If $\tan(A - B) = \frac{1}{\sqrt{3}}$ and $\tan(A + B) = \sqrt{3}$, then find the value of A and B.

TRIGONOMETRIC IDENTITIES

An equation involving trigonometric ratios of an angle is said to be a trigonometric identity if it is satisfied for all values of θ for which the given trigonometric ratios are defined.

- Identity (1) :** $\sin^2\theta + \cos^2\theta = 1$
 $\Rightarrow \sin^2\theta = 1 - \cos^2\theta$ and $\cos^2\theta = 1 - \sin^2\theta$.
- Identity (2) :** $\sec^2\theta = 1 + \tan^2\theta$
 $\Rightarrow \sec^2\theta - \tan^2\theta = 1$ and $\tan^2\theta = \sec^2\theta - 1$.
- Identity (3) :** $\operatorname{cosec}^2\theta = 1 + \cot^2\theta$
 $\Rightarrow \operatorname{cosec}^2\theta - \cot^2\theta = 1$ and $\cot^2\theta = \operatorname{cosec}^2\theta - 1$.

IMPORTANT QUESTIONS

Prove that: $\frac{\cos A - \sin A + 1}{\cos A + \sin A - 1} = \operatorname{cosec}A + \cot A$

Solution: LHS = $\frac{\cos A - \sin A + 1}{\cos A + \sin A - 1}$

(Dividing Numerator and Denominator by $\sin A$, we get)

$$\begin{aligned} & \frac{\frac{\cos A}{\sin A} - \frac{\sin A}{\sin A} + \frac{1}{\sin A}}{\frac{\cos A}{\sin A} + \frac{\sin A}{\sin A} - \frac{1}{\sin A}} = \frac{\cot A - 1 + \operatorname{cosec}A}{\cot A + 1 - \operatorname{cosec}A} \quad \left[\because \cot A = \frac{\cos A}{\sin A}, \operatorname{cosec}A = \frac{1}{\sin A} \right] \\ & = \frac{\cot A + \operatorname{cosec}A - 1}{\cot A + 1 - \operatorname{cosec}A} = \frac{\cot A + \operatorname{cosec}A - (\cos^2 A - \cot^2 A)}{\cot A + 1 - \operatorname{cosec}A} \quad [\because \operatorname{cosec}^2 A - \cot^2 A = 1] \\ & = \frac{\cot A + \operatorname{cosec}A - (\cos^2 A - \cot^2 A)}{\cot A + 1 - \operatorname{cosec}A} \\ & = \frac{(\operatorname{cosec}A + \cot A)(1 - \cos^2 A + \cot^2 A)}{\cot A + 1 - \operatorname{cosec}A} = \operatorname{cosec}A + \cot A = \text{RHS} \end{aligned}$$

Questions for Practice

Prove the following identities:

1. $\sec A (1 - \sin A)(\sec A + \tan A) = 1$.
2. $\frac{\cot A - \cos A}{\cot A + \cos A} = \frac{\operatorname{cosec}A - 1}{\operatorname{cosec}A + 1}$

3. $\frac{\sin \theta - \cos \theta + 1}{\sin \theta + \cos \theta - 1} = \frac{1}{\sec \theta - \tan \theta}$
4. $(\operatorname{cosec} \theta - \cot \theta)^2 = \frac{1 - \cos \theta}{1 + \cos \theta}$
5. $\frac{\cos A}{1 + \sin A} + \frac{1 + \sin A}{\cos A} = 2 \sec A$
6. $\frac{\tan \theta}{1 - \cot \theta} + \frac{\cot \theta}{1 - \tan \theta} = 1 + \sec \theta \operatorname{cosec} \theta$
7. $\frac{1 + \sec A}{\sec A} = \frac{\sin^2 A}{1 - \cos A}$
8. $\sqrt{\frac{1 + \sin A}{1 - \sin A}} = \sec A + \tan A$
9. $\frac{\sin \theta - 2 \sin^3 \theta}{2 \cos^3 \theta - \cos \theta} = \tan \theta$
10. $(\sin A + \operatorname{cosec} A)^2 + (\cos A + \sec A)^2 = 7 + \tan^2 A + \cot^2 A$
11. $(\operatorname{cosec} A - \sin A)(\sec A - \cos A) = \frac{1}{\tan A + \cot A}$
12. $\left(\frac{1 + \tan^2 A}{1 + \cot^2 A}\right) = \left(\frac{1 - \tan A}{1 - \cot A}\right)^2 = \tan^2 A$

ANGLE OF ELEVATION

In the below figure, the line AC drawn from the eye of the student to the top of the minar is called the *line of sight*. The student is looking at the top of the minar. The angle BAC, so formed by the line of sight with the horizontal, is called the *angle of elevation* of the top of the minar from the eye of the student. Thus, the **line of sight** is the line drawn from the eye of an observer to the point in the object viewed by the observer.

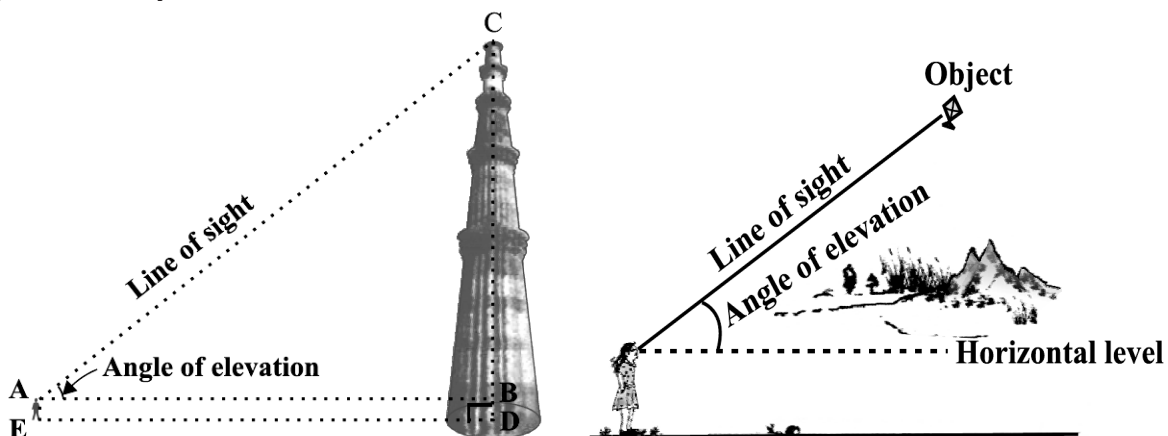

The **angle of elevation** of the point viewed is the angle formed by the line of sight with the horizontal when the point being viewed is above the horizontal level, i.e., the case when we raise our head to look at the object

ANGLE OF DEPRESSION

In the below figure, the girl sitting on the balcony is *looking down* at a flower pot placed on a stair of the temple. In this case, the line of sight is *below* the horizontal level. The angle so formed by the line of sight with the horizontal is called the *angle of depression*. Thus, the **angle of depression** of a point on the object being viewed is the angle formed by the line of sight with the horizontal when the

point is below the horizontal level, i.e., the case when we lower our head to look at the point being viewed

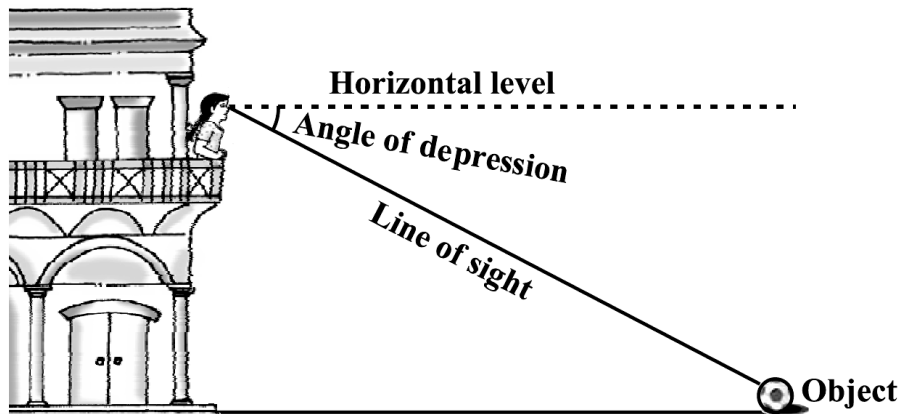

IMPORTANT QUESTIONS

The angles of depression of the top and the bottom of an 8 m tall building from the top of a multi-storeyed building are 30° and 45° , respectively. Find the height of the multi-storeyed building and the distance between the two buildings.

Solution : Let $PC = h$ m be the height of multistoreyed building and AB denotes the 8 m tall building.
 $BD = AC = x$ m, $PC = h = PD + DC = PD + AB = PD + 8$ m

So, $PD = h - 8$ m

Now, $\angle QPB = \angle PBD = 30^\circ$

Similarly, $\angle QPA = \angle PAC = 45^\circ$.

$$\text{In right } \triangle PBD, \tan 30^\circ = \frac{PD}{BD} \Rightarrow \frac{1}{\sqrt{3}} = \frac{h-8}{x} \Rightarrow x = (h-8)\sqrt{3} \text{ m} \dots\dots\dots (1)$$

$$\text{Also, In right } \triangle PAC, \tan 45^\circ = \frac{PC}{AC} \Rightarrow 1 = \frac{h}{x}$$

$$\Rightarrow x = h \text{ m} \dots\dots\dots (2)$$

From equations (1) and (2), we get $h = (h-8)\sqrt{3}$

$$\Rightarrow h = h\sqrt{3} - 8\sqrt{3} \Rightarrow h\sqrt{3} - h = 8\sqrt{3}$$

$$\Rightarrow h(\sqrt{3} - 1) = 8\sqrt{3} \Rightarrow h = \frac{8\sqrt{3}}{\sqrt{3} - 1}$$

$$\Rightarrow h = \frac{8\sqrt{3}}{\sqrt{3} - 1} \times \frac{\sqrt{3} + 1}{\sqrt{3} + 1} = \frac{8\sqrt{3}(\sqrt{3} + 1)}{3 - 1}$$

$$\Rightarrow h = \frac{8(3 + \sqrt{3})}{2} = 4(3 + \sqrt{3})m$$

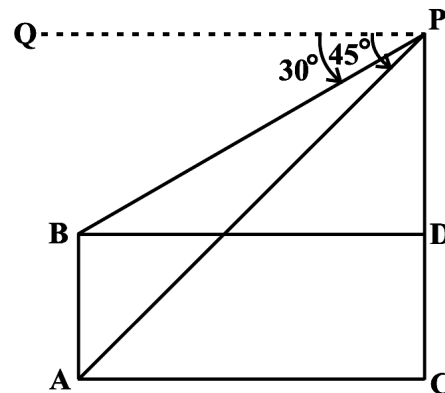

Hence, the height of the multi-storeyed building is $4(3 + \sqrt{3})m$ and the distance between the two buildings is also $4(3 + \sqrt{3})m$.

From a point on a bridge across a river, the angles of depression of the banks on opposite sides of the river are 30° and 45° , respectively. If the bridge is at a height of 3 m from the banks, find the width of the river.

Solution: Let A and B represent points on the bank on opposite sides of the river, so that AB is the width of the river. P is a point on the bridge at a height of 3 m, i.e., $DP = 3$ m.

Now, $AB = AD + DB$

In right $\triangle APD$, $\tan 30^\circ = \frac{PD}{AD} \Rightarrow \frac{1}{\sqrt{3}} = \frac{3}{AD}$

$$\Rightarrow AD = 3\sqrt{3} \text{ m}$$

Also, in right $\triangle PBD$, $\tan 45^\circ = \frac{PD}{BD} \Rightarrow 1 = \frac{3}{BD}$

$$\Rightarrow BD = 3 \text{ m}$$

Now, $AB = BD + AD = 3 + 3\sqrt{3} = 3(1 + \sqrt{3}) \text{ m}$

Therefore, the width of the river is $3(1 + \sqrt{3}) \text{ m}$

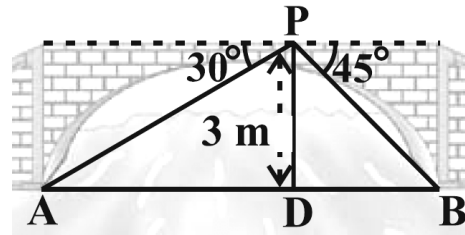

Questions for Practice

1. The angle of elevation of the top of a tower from a point on the ground, which is 30 m away from the foot of the tower, is 30° . Find the height of the tower.
2. A kite is flying at a height of 60 m above the ground. The string attached to the kite is temporarily tied to a point on the ground. The inclination of the string with the ground is 60° . Find the length of the string, assuming that there is no slack in the string.
3. A 1.5 m tall boy is standing at some distance from a 30 m tall building. The angle of elevation from his eyes to the top of the building increases from 30° to 60° as he walks towards the building. Find the distance he walked towards the building.
4. From a point on the ground, the angles of elevation of the bottom and the top of a transmission tower fixed at the top of a 20 m high building are 45° and 60° respectively. Find the height of the tower.
5. A statue, 1.6 m tall, stands on the top of a pedestal. From a point on the ground, the angle of elevation of the top of the statue is 60° and from the same point the angle of elevation of the top of the pedestal is 45° . Find the height of the pedestal.
6. The angle of elevation of the top of a building from the foot of the tower is 30° and the angle of elevation of the top of the tower from the foot of the building is 60° . If the tower is 50 m high, find the height of the building.
7. Two poles of equal heights are standing opposite each other on either side of the road, which is 80 m wide. From a point between them on the road, the angles of elevation of the top of the poles are 60° and 30° , respectively. Find the height of the poles and the distances of the point from the poles.
8. A TV tower stands vertically on a bank of a canal. From a point on the other bank directly opposite the tower, the angle of elevation of the top of the tower is 60° . From another point 20 m away from this point on the line joining this point to the foot of the tower, the angle of elevation of the top of the tower is 30° . Find the height of the tower and the width of the canal.
9. From the top of a 7 m high building, the angle of elevation of the top of a cable tower is 60° and the angle of depression of its foot is 45° . Determine the height of the tower.
10. As observed from the top of a 75 m high lighthouse from the sea-level, the angles of depression of two ships are 30° and 45° . If one ship is exactly behind the other on the same side of the lighthouse, find the distance between the two ships.
11. A 1.2 m tall girl spots a balloon moving with the wind in a horizontal line at a height of 88.2 m from the ground. The angle of elevation of the balloon from the eyes of the girl at any instant is 60° . After some time, the angle of elevation reduces to 30° . Find the distance travelled by the balloon during the interval.
12. A straight highway leads to the foot of a tower. A man standing at the top of the tower observes a car at an angle of depression of 30° , which is approaching the foot of the tower with a uniform speed. Six seconds later, the angle of depression of the car is found to be 60° . Find the time taken by the car to reach the foot of the tower from this point.
13. The angles of elevation of the top of a tower from two points at a distance of 4 m and 9 m from the base of the tower and in the same straight line with it are complementary. Prove that the height of the tower is 6 m.

MCQ QUESTIONS (1 mark)

- The value of $(\sin 30^\circ + \cos 30^\circ) - (\sin 60^\circ + \cos 60^\circ)$ is
(a) -1 (b) 0 (c) 1 (d) 2
- The value of $\frac{\tan 30^\circ}{\cot 60^\circ}$ is
(a) $\frac{1}{\sqrt{2}}$ (b) $\frac{1}{\sqrt{3}}$ (c) $\sqrt{3}$ (d) 1
- The value of $(\sin 45^\circ + \cos 45^\circ)$ is
(a) $\frac{1}{\sqrt{2}}$ (b) $\sqrt{2}$ (c) $\frac{\sqrt{3}}{2}$ (d) 1
- If $\cos A = \frac{4}{5}$, then the value of $\tan A$ is
(a) $\frac{3}{5}$ (b) $\frac{3}{4}$ (c) $\frac{4}{3}$ (d) $\frac{5}{3}$
- If $\sin A = \frac{1}{2}$, then the value of $\cot A$ is
(a) $\frac{1}{\sqrt{3}}$ (b) $\sqrt{3}$ (c) $\frac{\sqrt{3}}{2}$ (d) 1
- If $\cos(\alpha + \beta) = 0$, then $\sin(\alpha - \beta)$ can be reduced to
(a) $\cos \beta$ (b) $\cos 2\beta$ (c) $\sin \alpha$ (d) $\sin 2\alpha$
- If $\triangle ABC$ is right angled at C , then the value of $\cos(A+B)$ is
(a) 0 (b) 1 (c) $\frac{1}{2}$ (d) $\frac{\sqrt{3}}{2}$
- If $\sin A + \sin^2 A = 1$, then the value of the expression $(\cos^2 A + \cos^4 A)$ is
(a) 1 (b) $\frac{1}{2}$ (c) 2 (d) 3
- Given that $\sin \alpha = \frac{1}{2}$ and $\cos \beta = \frac{1}{2}$, then the value of $(\alpha + \beta)$ is
(a) 0° (b) 30° (c) 60° (d) 90°
- If $\sin \theta - \cos \theta = 0$, then the value of $(\sin^4 \theta + \cos^4 \theta)$ is
(a) 1 (b) $\frac{3}{4}$ (c) $\frac{1}{2}$ (d) $\frac{1}{4}$

CHAPTER – 10 CIRCLES

THEOREMS

- The tangent to a circle is perpendicular to the radius through the point of contact.
- The lengths of tangents drawn from an external point to a circle are equal.

Given : A circle $C(O, r)$ and two tangents say PQ and PR from an external point P .

To prove : $PQ = PR$.

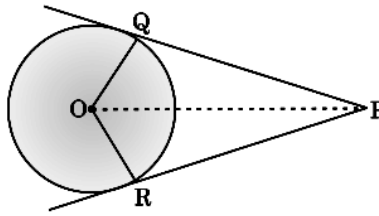

Construction : Join OQ , OR and OP .

Proof : In $\triangle OQP$ and $\triangle ORP$

$$OQ = OR$$

(radii of the same circle)

$$OP = OP$$

(Common)

$\angle Q = \angle R = \text{each } 90^\circ$ (The tangent at any point of a circle is perpendicular to the radius through the point of contact)

Hence $\triangle OQP \cong \triangle ORP$

(By RHS Criterion)

$$\therefore PQ = PR$$

(By CPCT)

Hence Proved.

IMPORTANT QUESTIONS

1. Prove that the tangent to a circle is perpendicular to the radius through the point of contact.
2. Prove that the lengths of the two tangents from an external point to a circle are equal.
3. From a point Q , the length of the tangent to a circle is 24 cm and the distance of Q from the centre is 25 cm. Find the radius of the circle
4. In the below figure, if TP and TQ are the two tangents to a circle with centre O so that $\angle POQ = 110^\circ$, then find $\angle PTQ$.

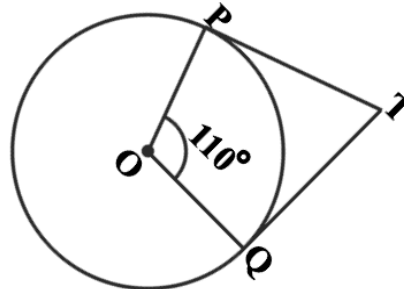

5. If tangents PA and PB from a point P to a circle with centre O are inclined to each other at angle of 80° , then find $\angle POA$
6. Prove that the tangents drawn at the ends of a diameter of a circle are parallel.
7. Prove that the perpendicular at the point of contact to the tangent to a circle passes through the centre.
8. The length of a tangent from a point A at distance 5 cm from the centre of the circle is 4 cm. Find the radius of the circle.
9. Two concentric circles are of radii 5 cm and 3 cm. Find the length of the chord of the larger circle which touches the smaller circle.
10. A quadrilateral $ABCD$ is drawn to circumscribe a circle. Prove that $AB + CD = AD + BC$
11. Prove that the angle between the two tangents drawn from an external point to a circle is supplementary to the angle subtended by the line-segment joining the points of contact at the centre.
12. Prove that the parallelogram circumscribing a circle is a rhombus.
13. Prove that opposite sides of a quadrilateral circumscribing a circle subtend supplementary angles at the centre of the circle.

14. Prove that in two concentric circles, the chord of the larger circle, which touches the smaller circle, is bisected at the point of contact.
15. XY and $X'Y'$ are two parallel tangents to a circle with centre O and another tangent AB with point of contact C intersecting XY at A and $X'Y'$ at B . Prove that $\angle AOB = 90^\circ$.

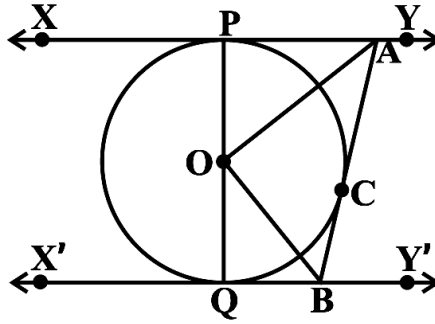

16. A triangle ABC is drawn to circumscribe a circle of radius 4 cm such that the segments BD and DC into which BC is divided by the point of contact D are of lengths 8 cm and 6 cm respectively. Find the sides AB and AC .

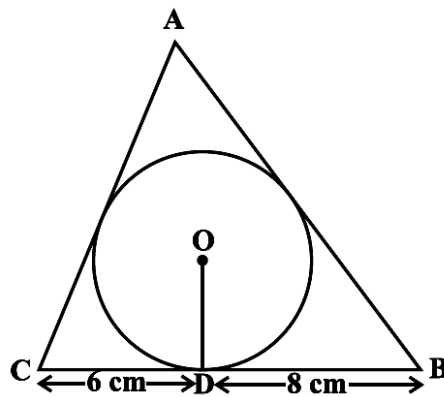

17. Two tangents TP and TQ are drawn to a circle with centre O from an external point T . Prove that $\angle PTQ = 2 \angle OPQ$.
18. PQ is a chord of length 8 cm of a circle of radius 5 cm. The tangents at P and Q intersect at a point T . Find the length TP .
19. Two tangents PQ and PR are drawn from an external point to a circle with centre O . Prove that $QORP$ is a cyclic quadrilateral.
20. If from an external point B of a circle with centre O , two tangents BC and BD are drawn such that $\angle DBC = 120^\circ$, prove that $BC + BD = BO$, i.e., $BO = 2BC$.
21. Prove that the tangents drawn at the ends of a chord of a circle make equal angles with the chord.
22. Prove that a diameter AB of a circle bisects all those chords which are parallel to the tangent at the point A .
23. From an external point P , two tangents, PA and PB are drawn to a circle with centre O . At one point E on the circle tangent is drawn which intersects PA and PB at C and D , respectively. If $PA = 10$ cm, find the perimeter of the triangle PCD .
24. In a right triangle ABC in which $\angle B = 90^\circ$, a circle is drawn with AB as diameter intersecting the hypotenuse AC at P . Prove that the tangent to the circle at P bisects BC .

MCQ (1 MARK)

1. Find the length of tangent drawn to a circle with radius 7 cm from a point 25 cm away from the centre.
 (a) 24 cm (b) 27 cm (c) 26 cm (d) 25 cm

2. A point P is 26 cm away from the centre of a circle and the length of the tangent drawn from P to the circle is 24 cm. Find the radius of the circle.
 (a) 11 cm (b) 10 cm (c) 16 cm (d) 15 cm
3. From an external point P, tangents PA and PB are drawn to a circle with centre O. If CD is the tangent to the circle at a point E and PA = 14 cm, find the perimeter of the Δ PCD.
 (a) 28 cm (b) 27 cm (c) 26 cm (d) 25 cm

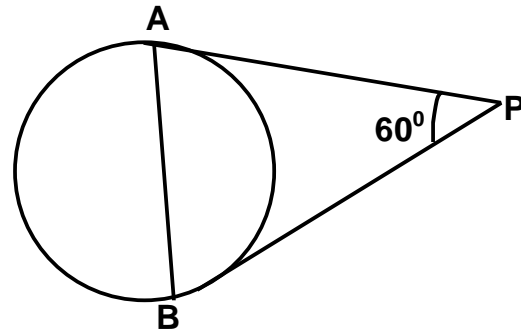
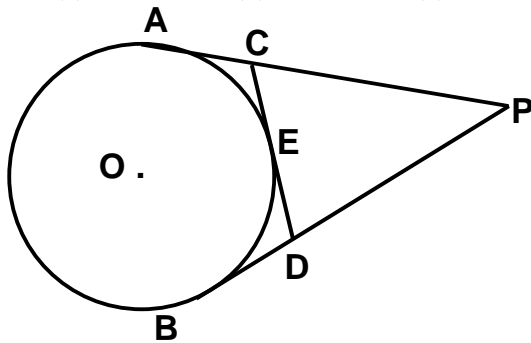

4. In the above sided figure, PA and PB are tangents such that PA = 9cm and \angle APB = 60° . Find the length of the chord AB.
 (a) 4 cm (b) 7 cm (c) 6 cm (d) 9 cm
5. In the below figure the circle touches all the sides of a quadrilateral ABCD whose three sides are AB = 6 cm, BC = 7 cm, CD = 4 cm. Find AD.
 (a) 4 cm (b) 3 cm (c) 6 cm (d) 9 cm

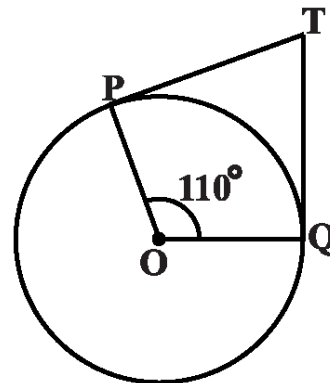
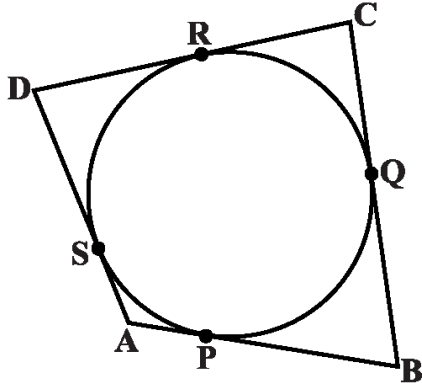

6. In the above sided Fig., if TP and TQ are the two tangents to a circle with centre O so that \angle POQ = 110° , then \angle PTQ is equal to
 (a) 60° (b) 70° (c) 80° (d) 90°
7. If tangents PA and PB from a point P to a circle with centre O are inclined to each other at angle of 80° , then \angle POA is equal to
 (a) 60° (b) 70° (c) 80° (d) 50°
8. The length of a tangent from a point A at distance 5 cm from the centre of the circle is 4 cm. Find the radius of the circle.
 (a) 4 cm (b) 3 cm (c) 6 cm (d) 5 cm
9. From a point P, 10 cm away from the centre of a circle, a tangent PT of length 8 cm is drawn. Find the radius of the circle.
 (a) 4 cm (b) 7 cm (c) 6 cm (d) 5 cm
10. PT is tangent to a circle with centre O, OT = 56 cm, TP = 90 cm, find OP
 (a) 104 cm (b) 107 cm (c) 106 cm (d) 105 cm

11. TP and TQ are the two tangents to a circle with center O so that angle $\angle POQ = 130^\circ$. Find $\angle PTQ$.
 (a) 50° (b) 70° (c) 80° (d) none of these
12. From a point Q, the length of the tangent to a circle is 40 cm and the distance of Q from the centre is 41 cm. Find the radius of the circle.
 (a) 4 cm (b) 3 cm (c) 6 cm (d) 9 cm
13. The common point of a tangent to a circle with the circle is called _____
 (a) centre (b) point of contact (c) end point (d) none of these.

CHAPTER – 12

AREAS RELATED TO CIRCLES

AREA AND PERIMETER OF CIRCLE, QUADRANT, SEMICIRCLE

Area of Circle = πr^2 , Perimeter of Circle = Circumference = $2\pi r$

Area of Semicircle = $\frac{1}{2}\pi r^2$, Perimeter of Semicircle = $\pi r + 2r$

Area of Quadrant = $\frac{1}{4}\pi r^2$, Perimeter of Quadrant = $\frac{1}{2}\pi r + 2r$

IMPORTANT QUESTIONS

Find the diameter of the circle whose area is equal to the sum of the areas of the two circles of diameters 20 cm and 48 cm.

Solution: Here, radius r_1 of first circle = $20/2$ cm = 10 cm

and radius r_2 of the second circle = $48/2$ cm = 24 cm

Therefore, sum of their areas = $\pi r_1^2 + \pi r_2^2 = \pi (10)^2 + \pi (24)^2 = \pi \times 676$

Let the radius of the new circle be r cm. Its area = πr^2

Therefore, $\pi r^2 = \pi \times 676 \Rightarrow r^2 = 676 \Rightarrow r = 26$

Thus, radius of the new circle = 26 cm

Hence, diameter of the new circle = 2×26 cm = 52 cm

Questions for Practice

- The radii of two circles are 19 cm and 9 cm respectively. Find the radius of the circle which has circumference equal to the sum of the circumferences of the two circles.
- The radii of two circles are 8 cm and 6 cm respectively. Find the radius of the circle having area equal to the sum of the areas of the two circles.
- The wheels of a car are of diameter 80 cm each. How many complete revolutions does each wheel make in 10 minutes when the car is travelling at a speed of 66 km per hour?
- Find the area of a quadrant of a circle whose circumference is 22 cm.

AREAS OF SECTOR AND SEGMENT OF A CIRCLE

Area of the sector of angle $\theta = \frac{\theta}{360^\circ} \times \pi r^2$, where r is the radius of the circle and θ the angle of the sector in degrees

length of an arc of a sector of angle $\theta = \frac{\theta}{360^\circ} \times 2\pi r$, where r is the radius of the circle and θ the angle of the sector in degrees

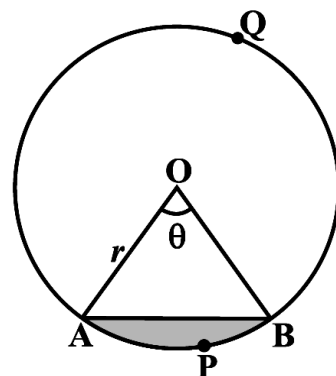

Area of the segment APB = Area of the sector OAPB – Area of Δ OAB

$$= \frac{\theta}{360^\circ} \times \pi r^2 - \text{area of } \Delta \text{ OAB}$$

☞ Area of the major sector OAQB = πr^2 – Area of the minor sector OAPB

☞ Area of major segment AQB = πr^2 – Area of the minor segment APB

☞ Area of segment of a circle = Area of the corresponding sector – Area of the corresponding triangle

IMPORTANT QUESTIONS

Find the area of the sector of a circle with radius 4 cm and of angle 30° . Also, find the area of the corresponding major sector (Use $\pi = 3.14$).

Solution : Here, radius, $r = 4$ cm, $\theta = 30^\circ$,

$$\begin{aligned} \text{We know that Area of sector} &= \frac{\theta}{360^\circ} \times \pi r^2 = \frac{30^\circ}{360^\circ} \times 3.14 \times 4 \times 4 = \frac{1}{12} \times 3.14 \times 4 \times 4 \\ &= \frac{12.56}{3} = 4.19 \text{ cm}^2 \text{ (approx.)} \end{aligned}$$

Area of the corresponding major sector

$$= \pi r^2 - \text{area of sector OAPB}$$

$$= (3.14 \times 16 - 4.19) \text{ cm}^2$$

$$= 46.05 \text{ cm}^2 = 46.1 \text{ cm}^2 \text{ (approx.)}$$

A chord of a circle of radius 10 cm subtends a right angle at the centre. Find the area of the corresponding : (i) minor segment (ii) major sector. (Use $\pi = 3.14$)

Solutions: Here, radius, $r = 10$ cm, $\theta = 90^\circ$,

$$\text{We know that Area of minor sector} = \frac{\theta}{360^\circ} \times \pi r^2 = \frac{90^\circ}{360^\circ} \times 3.14 \times 10 \times 10 = \frac{1}{4} \times 314 = 78.5 \text{ cm}^2$$

$$\text{and Area of triangle AOB} = \frac{1}{2} \times b \times h = \frac{1}{2} \times 10 \times 10 = 50 \text{ cm}^2$$

Area of minor segment = Area of minor sector –

$$\text{Area of triangle AOB} = 78.5 - 50 = 28.5 \text{ cm}^2.$$

$$\text{Area of circle} = \pi r^2 = 3.14 \times 10 \times 10 = 314 \text{ cm}^2$$

Area of major sector = Area of circle – Area of minor sector

$$= 314 - 78.5 = 235.5 \text{ cm}^2$$

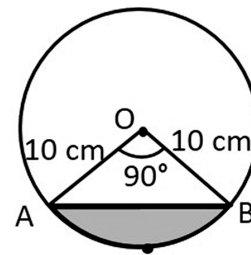

Questions for Practice

- Find the area of the segment AYB shown in below figure, if radius of the circle is 21 cm and \angle AOB = 120° .

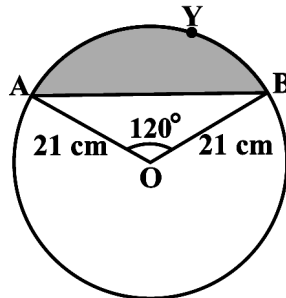

- Find the area of a sector of a circle with radius 6 cm if angle of the sector is 60° .
- The length of the minute hand of a clock is 14 cm. Find the area swept by the minute hand in 5 minutes.
- A horse is tied to a peg at one corner of a square shaped grass field of side 15 m by means of a 5 m long rope. Find (i) the area of that part of the field in which the horse can graze. (ii) the increase in the grazing area if the rope were 10 m long instead of 5 m. (Use $\pi = 3.14$)
- A brooch is made with silver wire in the form of a circle with diameter 35 mm. The wire is also used in making 5 diameters which divide the circle into 10 equal sectors. Find : (i) the total length of the silver wire required. (ii) the area of each sector of the brooch.
- In a circle of radius 21 cm, an arc subtends an angle of 60° at the centre. Find: (i) the length of the arc (ii) area of the sector formed by the arc (iii) area of the segment formed by the corresponding chord
- A chord of a circle of radius 15 cm subtends an angle of 60° at the centre. Find the areas of the corresponding minor and major segments of the circle. (Use $\pi = 3.14$ and $\sqrt{3} = 1.73$)
- A chord of a circle of radius 12 cm subtends an angle of 120° at the centre. Find the area of the corresponding segment of the circle. (Use $\pi = 3.14$ and $\sqrt{3} = 1.73$)
- A car has two wipers which do not overlap. Each wiper has a blade of length 25 cm sweeping through an angle of 115° . Find the total area cleaned at each sweep of the blades.
- To warn ships for underwater rocks, a lighthouse spreads a red coloured light over a sector of angle 80° to a distance of 16.5 km. Find the area of the sea over which the ships are warned. (Use $\pi = 3.14$)

AREA OF SHADED REGION BASED QUESTIONS

IMPORTANT QUESTIONS

In the adjoining figure, two circular flower beds have been shown on two sides of a square lawn ABCD of side 56 m. If the centre of each circular flower bed is the point of intersection O of the diagonals of the square lawn, find the sum of the areas of the lawn and the flower beds.

Solution: Here, side of square ABCD, $a = 56$ m

$$\text{diagonal of square} = a\sqrt{2} = 56\sqrt{2}$$

$$\text{radius, } r = OA = OB = OC = OD = \frac{56\sqrt{2}}{2} = 28\sqrt{2} \text{ cm}$$

Now, Area of sector OAB = Area of sector ODC

$$= \frac{\theta}{360^\circ} \times \pi r^2 = \frac{90^\circ}{360^\circ} \times \frac{22}{7} \times r^2 = \frac{1}{4} \times \frac{22}{7} \times r^2$$

$$\text{and Area of } \triangle OAD = \text{Area of } \triangle OBC = \frac{1}{2} \times r \times r = \frac{1}{2} \times r^2$$

Total area = Area of sector OAB + Area of sector ODC
+ Area of $\triangle OAD$ + Area of $\triangle OBC$

$$= \frac{1}{4} \times \frac{22}{7} \times r^2 + \frac{1}{4} \times \frac{22}{7} \times r^2 + \frac{1}{2} \times r^2 + \frac{1}{2} \times r^2$$

$$= 2 \times \frac{1}{4} \times \frac{22}{7} \times r^2 + 2 \times \frac{1}{2} \times r^2 = \frac{11}{7} \times r^2 + r^2 = \left(\frac{11}{7} + 1 \right) r^2$$

$$= \frac{18}{7} \times 28 \times 28 \times 2 = 4032 \text{ cm}^2$$

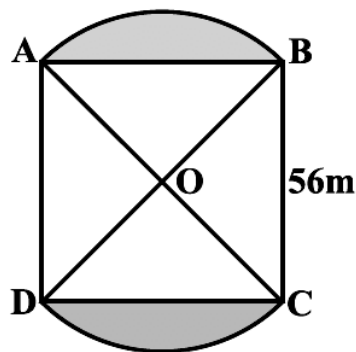

Questions for Practice

- Find the area of the shaded region in below left figure, where ABCD is a square of side 14 cm.

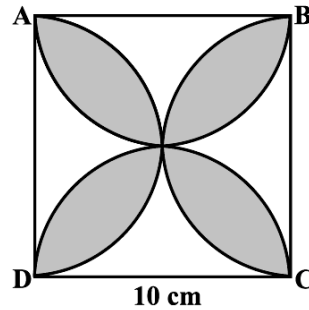
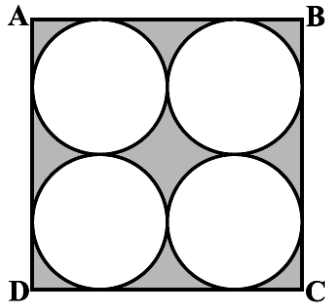

- Find the area of the shaded design in above right figure, where ABCD is a square of side 10 cm and semicircles are drawn with each side of the square as diameter. (Use $\pi = 3.14$)
- Find the area of the shaded region in below left figure, if ABCD is a square of side 14 cm and APD and BPC are semicircles.

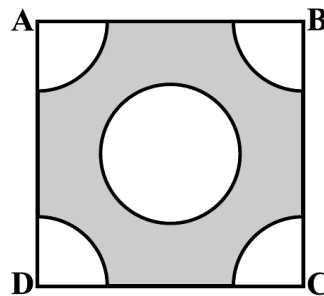
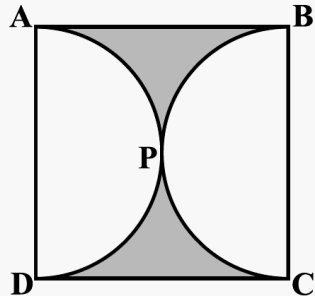

- From each corner of a square of side 4 cm a quadrant of a circle of radius 1 cm is cut and also a circle of diameter 2 cm is cut as shown in above right sided figure. Find the area of the remaining portion of the square.
- In the below left figure, ABCD is a square of side 14 cm. With centres A, B, C and D, four circles are drawn such that each circle touch externally two of the remaining three circles. Find the area of the shaded region.

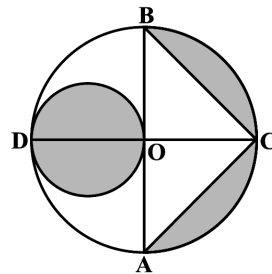
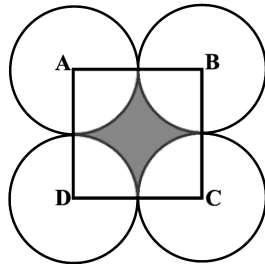

- In the above right sided figure, AB and CD are two diameters of a circle (with centre O) perpendicular to each other and OD is the diameter of the smaller circle. If $OA = 7$ cm, find the area of the shaded region.
- In the below left figure, ABC is a quadrant of a circle of radius 14 cm and a semicircle is drawn with BC as diameter. Find the area of the shaded region.

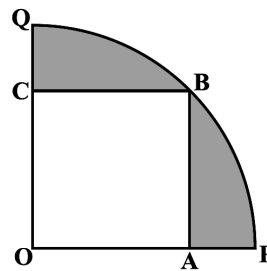
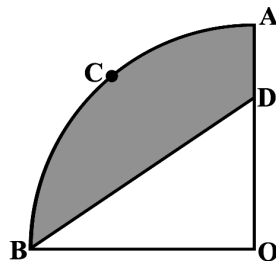

- In the above right sided figure, OACB is a quadrant of a circle with centre O and radius 3.5 cm. If $OD = 2$ cm, find the area of the (i) quadrant OACB, (ii) shaded region.
- In the below figure, a square OACB is inscribed in a quadrant OPBQ. If $OA = 20$ cm, find the area of the shaded region. (Use $\pi = 3.14$)

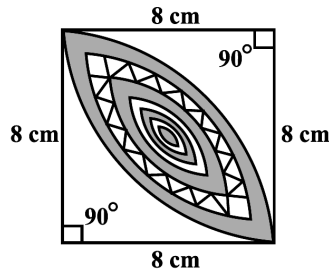
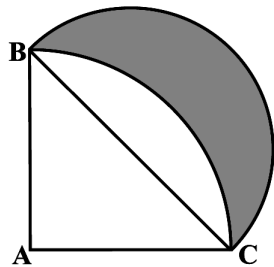

10. Calculate the area of the designed region in above right sided figure, common between the two quadrants of circles of radius 8 cm each.

MCQ QUESTIONS (1 mark)

- If the area of a circle is 154 cm^2 , then its perimeter is
(a) 11 cm (b) 22 cm (c) 44 cm (d) 55 cm
- If θ is the angle (in degrees) of a sector of a circle of radius r , then area of the sector is
(a) $\frac{\pi r^2 \theta}{360^\circ}$ (b) $\frac{\pi r^2 \theta}{180^\circ}$ (c) $\frac{2\pi r \theta}{360^\circ}$ (d) $\frac{2\pi r \theta}{180^\circ}$
- If the sum of the areas of two circles with radii R_1 and R_2 is equal to the area of a circle of radius R , then
(a) $R_1 + R_2 = R$ (b) $R_1^2 + R_2^2 = R^2$ (c) $R_1 + R_2 < R$ (d) $R_1^2 + R_2^2 < R^2$
- Area of the largest triangle that can be inscribed in a semi-circle of radius r units is
(a) r^2 sq. units (b) $\frac{1}{2} r^2$ sq. units (c) $2 r^2$ sq. units (d) $\sqrt{2} r^2$ sq. units
- If the perimeter of a circle is equal to that of a square, then the ratio of their areas is
(a) 22 : 7 (b) 14 : 11 (c) 7 : 22 (d) 11 : 14
- The area of the circle that can be inscribed in a square of side 6 cm is
(a) $36 \pi \text{ cm}^2$ (b) $18 \pi \text{ cm}^2$ (c) $12 \pi \text{ cm}^2$ (d) $9 \pi \text{ cm}^2$
- The area of the square that can be inscribed in a circle of radius 8 cm is
(a) 256 cm^2 (b) 128 cm^2 (c) $64\sqrt{2} \text{ cm}^2$ (d) 64 cm^2
- The radius of a circle whose circumference is equal to the sum of the circumferences of the two circles of diameters 36cm and 20 cm is
(a) 56 cm (b) 42 cm (c) 28 cm (d) 16 cm
- The diameter of a circle whose area is equal to the sum of the areas of the two circles of radii 24 cm and 7 cm is
(a) 31 cm (b) 25 cm (c) 62 cm (d) 50 cm
- A wire is looped in the form of a circle of radius 28 cm. It is rebent into a square form. Determine the length of the side of the square.
(a) 42 cm (b) 44 cm (c) 46 cm (d) 48 cm
- A circular part, 42 m in diameter has a path 3.5 m wide running round it on the outside. Find the cost of gravelling the path at Rs. 4 per m^2 .

- (a) Rs. 2800 (b) Rs. 2020 (c) Rs. 2002 (d) none of these

12. The diameter of the wheels of a bus is 140 cm. How many revolutions per minute must a wheel make in order to move a t a speed of 66km/hr?

- (a) 240 (b) 250 (c) 260 (d) 270

CHAPTER – 13 SURFACE AREAS AND VOLUMES

IMPORTANT FORMULAE

Name of the Solid	Curved Surface Area	Total Surface Area	Volume
Cuboid	$2h(l+b)$	$2(lb+bh+hl)$	lbh
Cube	$4a^2$	$6a^2$	a^3
Right Circular Cylinder	$2\pi rh$	$2\pi r(r+h)$	$\pi r^2 h$
Right Circular Cone	πrl	$2\pi r(r+l)$	$\frac{1}{3}\pi r^2 h$
Sphere	–	$4\pi r^2$	$\frac{4}{3}\pi r^3$
Hemisphere	$2\pi r^2$	$3\pi r^2$	$\frac{2}{3}\pi r^3$
Frustum of a Cone	$\pi(r_1+r_2)l$ where $l = \sqrt{h^2 + (r_1 - r_2)^2}$	$\pi(r_1+r_2)l$ + $\pi r_1^2 + \pi r_2^2$	$\frac{1}{3}\pi h(r_1^2 + r_2^2 + r_1 r_2)$

COMBINATIONAL FIGURE BASED QUESTIONS

IMPORTANT QUESTIONS

The decorative block is shown in below left figure made of two solids — a cube and a hemisphere. The base of the block is a cube with edge 5 cm, and the hemisphere fixed on the top has a diameter of 4.2 cm. Find the total surface area of the block.

Solution: The total surface area of the cube = $6 \times (\text{edge})^2 = 6 \times 5 \times 5 \text{ cm}^2 = 150 \text{ cm}^2$.

So, the surface area of the block = TSA of cube – base area of hemisphere + CSA of hemisphere
 $= 150 - \pi r^2 + 2\pi r^2 = (150 + \pi r^2) \text{ cm}^2$

$$= 150 + \left(\frac{22}{7} \times \frac{4.2}{2} \times \frac{4.2}{2} \right) \text{ cm}^2 = 150 + 13.86 \text{ cm}^2 = 163.86 \text{ cm}^2$$

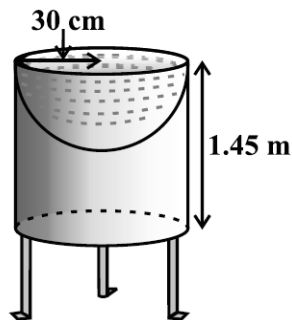
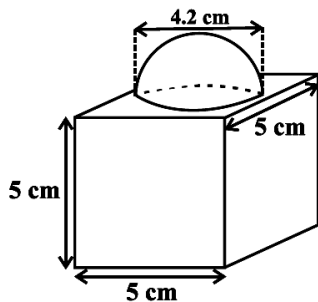

Mayank made a bird-bath for his garden in the shape of a cylinder with a hemispherical depression at one end. The height of the cylinder is 1.45 m and its radius is 30 cm. Find the total surface area of the bird-bath.

Solution : Let h be height of the cylinder, and r the common radius of the cylinder and hemisphere. (See above right sided figure)

Total surface area of the bird-bath = CSA of cylinder + CSA of hemisphere

$$= 2\pi rh + 2\pi r^2 = 2\pi r (h + r) = 2 \times \frac{22}{7} \times 30(145 + 30) = 2 \times \frac{22}{7} \times 30 \times 175 = 33000 \text{ cm}^2 = 3.3 \text{ m}^2$$

A juice seller was serving his customers using glasses as shown in below figure. The inner diameter of the cylindrical glass was 5 cm, but the bottom of the glass had a hemispherical raised portion which reduced the capacity of the glass. If the height of a glass was 10 cm, find the apparent capacity of the glass and its actual capacity. (Use $\pi = 3.14$.)

Solution: Here, inner diameter = 5 cm. height, $h = 10$ cm

So, radius, $r = \frac{5}{2}$ cm

Apparent capacity of the glass = Volume of cylinder – Volume of hemisphere

$$= \pi r^2 h - \frac{2}{3} \pi r^3 = \pi r^2 \left(h - \frac{2}{3} r \right) = 3.14 \times \frac{5}{2} \times \frac{5}{2} \times \left(10 - \frac{2}{3} \times \frac{5}{2} \right)$$

$$= 3.14 \times \frac{25}{4} \times \frac{25}{3} = \frac{19625}{12} = 163.54 \text{ cm}^3$$

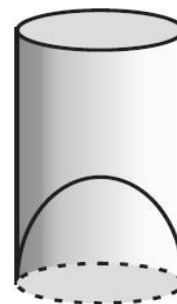

Questions for Practice

1. A wooden article was made by scooping out a hemisphere from each end of a solid cylinder (see below left figure). If the height of the cylinder is 10 cm, and its base is of radius 3.5 cm, find the total surface area of the article.

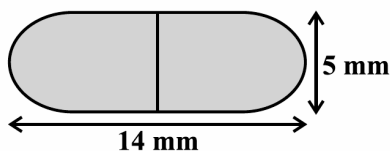
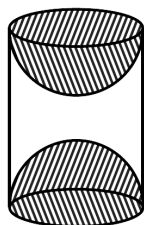

2. A medicine capsule is in the shape of a cylinder with two hemispheres stuck to each of its ends (see above right sided figure). The length of the entire capsule is 14 mm and the diameter of the capsule is 5 mm. Find its surface area.
3. A tent is in the shape of a cylinder surmounted by a conical top. If the height and diameter of the cylindrical part are 2.1 m and 4 m respectively, and the slant height of the top is 2.8 m, find the area of the canvas used for making the tent. Also, find the cost of the canvas of the tent at the rate of Rs 500 per m^2 .
4. From a solid cylinder whose height is 2.4 cm and diameter 1.4 cm, a conical cavity of the same height and same diameter is hollowed out. Find the total surface area of the remaining solid to the nearest cm^2 .

5. A toy is in the form of a cone of radius 3.5 cm mounted on a hemisphere of same radius. The total height of the toy is 15.5 cm. Find the total surface area of the toy.
6. A solid toy is in the form of a hemisphere surmounted by a right circular cone. The height of the cone is 2 cm and the diameter of the base is 4 cm. Determine the volume of the toy. If a right circular cylinder circumscribes the toy, find the difference of the volumes of the cylinder and the toy. (Take $\pi = 3.14$)
7. A gulab jamun, contains sugar syrup up to about 30% of its volume. Find approximately how much syrup would be found in 45 gulab jamuns, each shaped like a cylinder with two hemispherical ends with length 5 cm and diameter 2.8 cm
8. A solid iron pole consists of a cylinder of height 220 cm and base diameter 24 cm, which is surmounted by another cylinder of height 60 cm and radius 8 cm. Find the mass of the pole, given that 1 cm³ of iron has approximately 8g mass. (Use $\pi = 3.14$)
9. A solid consisting of a right circular cone of height 120 cm and radius 60 cm standing on a hemisphere of radius 60 cm is placed upright in a right circular cylinder full of water such that it touches the bottom. Find the volume of water left in the cylinder, if the radius of the cylinder is 60 cm and its height is 180 cm.

MCQ QUESTIONS (1 mark)

1. A cylindrical pencil sharpened at one edge is the combination of
 (a) a cone and a cylinder (b) frustum of a cone and a cylinder
 (c) a hemisphere and a cylinder (d) two cylinders.
2. A surahi is the combination of
 (a) a sphere and a cylinder (b) a hemisphere and a cylinder
 (c) two hemispheres (d) a cylinder and a cone.
3. The shape of a gilli, in the gilli-danda game (see below figure), is a combination of
 (a) two cylinders (b) a cone and a cylinder
 (c) two cones and a cylinder (d) two cylinders and a cone



4. A shuttle cock used for playing badminton has the shape of the combination of
 (a) a cylinder and a sphere (b) a cylinder and a hemisphere
 (c) a sphere and a cone (d) frustum of a cone and a hemisphere
5. A cone is cut through a plane parallel to its base and then the cone that is formed on one side of that plane is removed. The new part that is left over on the other side of the plane is called
 (a) a frustum of a cone (b) cone (c) cylinder (d) sphere
6. If two solid hemispheres of same base radius r are joined together along their bases, then curved surface area of this new solid is
 (a) $4\pi r^2$ (b) $6\pi r^2$ (c) $3\pi r^2$ (d) $8\pi r^2$
7. A right circular cylinder of radius r cm and height h cm ($h > 2r$) just encloses a sphere of diameter
 (a) r cm (b) $2r$ cm (c) h cm (d) $2h$ cm
8. During conversion of a solid from one shape to another, the volume of the new shape will
 (a) increase (b) decrease (c) remain unaltered (d) be doubled

9. In a right circular cone, the cross-section made by a plane parallel to the base is a
 (a) circle (b) frustum of a cone (c) sphere (d) hemisphere
10. The volume of a cube is 2744 cm^3 . Its surface area is
 (a) 196 cm^2 (b) 1176 cm^2 (c) 784 cm^2 (d) 588 cm^2
11. The ratio of the total surface area to the lateral surface area of a cylinder with base radius 80 cm and height 20 cm is
 (a) 1 : 2 (b) 2 : 1 (c) 3 : 1 (d) 5 : 1
12. The height of a cylinder is 14 cm and its curved surface area is 264 cm^2 . The volume of the cylinder is
 (a) 296 cm^3 (b) 396 cm^3 (c) 369 cm^3 (d) 503 cm^3
13. The ratio of the volumes of two spheres is 8 : 27. The ratio between their surface areas is
 (a) 2 : 3 (b) 4 : 27 (c) 8 : 9 (d) 4 : 9
14. The radii of the base of a cylinder and a cone are in the ratio 3 : 4 and their heights are in the ratio 2 : 3, then ratio of their volumes is
 (a) 9 : 8 (b) 9 : 4 (c) 3 : 1 (d) 27 : 64
15. If two cubes, each of edge 4 cm are joined end to end, then the surface area of the resulting cuboid is
 (a) 100 cm^2 (b) 160 cm^2 (c) 200 cm^2 (d) 80 cm^2
16. The curved surface area of a cylinder is 264 m^2 and its volume is 924 m^3 . The ratio of its diameter to its height is
 (a) 3 : 7 (b) 7 : 3 (c) 6 : 7 (d) 7 : 6
17. The radius of spherical balloon increases from 8 cm to 12 cm. The ratio of the surface areas of the balloon in two cases is
 (a) 2 : 3 (b) 3 : 2 (c) 8 : 27 (d) 4 : 9
18. Volumes of two spheres are in the ratio 64:27. The ratio of their surface areas is
 (a) 3 : 4 (b) 4 : 3 (c) 9 : 16 (d) 16 : 9

CHAPTER – 14 STATISTICS

MEAN OF GROUPED DATA

Direct method

$$\text{Mean, } \bar{x} = \frac{\sum f_i x_i}{\sum f_i}$$

Assume mean method or Short-cut method

$$\text{Mean, } \bar{x} = A + \frac{\sum f_i d_i}{\sum f_i} \text{ where } d_i = x_i - A$$

Step Deviation method (This method deleted but student can use this method also)

$$\text{Mean, } \bar{x} = A + \frac{\sum f_i u_i}{\sum f_i} \times h \quad \text{where } u = \frac{x_i - A}{h}$$

MODE OF GROUPED DATA

$$\text{Mode} = l + \left(\frac{f_1 - f_0}{2f_1 - f_0 - f_2} \right) \times h$$

where l = lower limit of the modal class,

h = size of the class interval (assuming all class sizes to be equal),

f_1 = frequency of the modal class,

f_0 = frequency of the class preceding the modal class,

f_2 = frequency of the class succeeding the modal class.

➤ **Cumulative Frequency:** The cumulative frequency of a class is the frequency obtained by adding the frequencies of all the classes preceding the given class.

MEDIAN OF GROUPED DATA

$$\text{Median} = l + \left(\frac{\frac{n}{2} - cf}{f} \right) \times h$$

where l = lower limit of median class,

n = number of observations,

cf = cumulative frequency of class preceding the median class,

f = frequency of median class,

h = class size (assuming class size to be equal).

EMPIRICAL FORMULA

$$3\text{Median} = \text{Mode} + 2\text{Mean}$$

IMPORTANT QUESTIONS

1. Find the mean of the following data:

Class Interval	10 – 25	25 – 40	40 – 55	55 – 70	70 – 85	85 – 100
Frequency	2	3	7	6	6	6

2. Find the mean percentage of female teachers of the following data:

Percentage of female teachers	15 – 25	25 – 35	35 – 45	45 – 55	55 – 65	65 – 75	75 – 85
Number of States/U.T	6	11	7	4	4	2	1

3. A survey was conducted by a group of students as a part of their environment awareness programme, in which they collected the following data regarding the number of plants in 20 houses in a locality. Find the mean number of plants per house.

Number of plants	0 – 2	2 – 4	4 – 6	6 – 8	8 – 10	10 – 12	12 – 14
Number of houses	1	2	1	5	6	2	3

4. Find the mean daily wages of the workers of the factory by using an appropriate method for the following data:

Daily wages (in Rs)	100 – 120	120 – 140	140 – 160	160 – 180	180 – 200
Number of workers	12	14	8	6	10

5. Find the mean number of mangoes kept in a packing box for the following data:

Number of mangoes	50 – 52	53 – 55	56 – 58	59 – 61	62 – 64
Number of boxes	15	110	135	115	25

6. The following table gives the literacy rate (in percentage) of 35 cities. Find the mean literacy rate.

Literacy rate (in %)	45 – 55	55 – 65	65 – 75	75 – 85	85 – 95
Number of cities	3	10	11	8	3

7. Find the mean daily expenditure on food for the following data:

Daily expenditure (in Rs.)	100 – 150	150 – 200	200 – 250	250 – 300	300 – 350
Number of households	4	5	12	2	2

8. Find the mean, mode and median for the following frequency distribution.

Class	0-10	10-20	20-30	30-40	40-50	Total
Frequency	8	16	36	34	6	100

9. The frequency distribution table of agriculture holdings in a village is given below:

Area of land(in ha)	1-3	3-5	5-7	7-9	9-11	11-13
No. of families	20	45	80	55	40	12

Find the modal agriculture holdings of the village.

10. Find the mode age of the patients from the following distribution :

Age(in years)	6-15	16-25	26-35	36-45	46-55	56-65
No. of patients	6	11	21	23	14	5

11. Find the mode of the following frequency distribution:

Class	25-30	30-35	35-40	40-45	45-50	50-55
Frequency	25	34	50	42	38	14

12. Find the modal height of maximum number of students from the following distribution:

Height(in cm)	160-162	163-165	166-168	169-171	172-174
No. of students	15	118	142	127	18

13. A survey regarding the heights (in cms) of 50 girls of a class was conducted and the following data was obtained. Find the mode

Height(in cm)	120-130	130-140	140-150	150-160	160-170	Total
No. of girls	2	8	12	20	8	50

14. Find the median of the following frequency distribution:

Class	75-84	85-94	95-104	105-114	115-124	125-134	135-144
Frequency	8	11	26	31	18	4	2

15. The percentage of marks obtained by 100 students in an examination are given below:

Marks	30-35	35-40	40-45	45-50	50-55	55-60	60-65
No. of Students	14	16	18	23	18	8	3

Determine the median percentage of marks.

16. Weekly income of 600 families is as under:

Income(in Rs.)	0-1000	1000-2000	2000-3000	3000-4000	4000-5000	5000-6000
No. of Families	250	190	100	40	15	5

Compute the median income.

17. Find the median of the following frequency distribution:

Marks	0 – 5	5 – 10	10 – 15	15 – 20	20 – 25	25 – 30	30 – 35	35 – 40
Number of students	8	12	20	12	18	13	10	7

18. The following table gives the distribution of the life time of 500 neon lamps:

Life time (in hrs)	1500 – 2000	2000 – 2500	2500 – 3000	3000 – 3500	3500 – 4000	4000 – 4500	4500 – 5000
Number of Lamps	24	86	90	115	95	72	18

Find the median life time of a lamp.

19. Find the median marks for the following distribution:

Marks	Below 10	Below 20	Below 30	Below 40	Below 50	Below 60
No. of Students	6	15	29	41	60	70

20. Find the median wages for the following frequency distribution:

Wages per day	61-70	71-80	81-90	91-100	101-110	111-120
No. of workers	5	15	20	30	10	8

21. Find the median marks for the following distribution:

Marks	11-15	16-20	21-25	26-30	31-35	36-40	41-45	46-50
No. of Students	2	3	6	7	14	12	4	2

22. The median of the distribution given below is 14.4. Find the values of x and y , if the sum of frequency is 20.

Class Interval	0 – 6	6 – 12	12 – 18	18 – 24	24 – 30
Frequency	4	x	5	y	1

23. The arithmetic mean of the following frequency distribution is 50. Find the value of p .

Class	0-20	20-40	40-60	60-80	80-100
Frequency	17	p	32	24	19

24. Find 'p' if the mean of the given data is 15.45.

Class Interval	0 – 6	6 – 12	12 – 18	18 – 24	24 – 30
Frequency	6	8	p	9	7

25. Find the value of p , if the mode of the following distribution is 48:

Class	0 – 10	10 – 20	20 – 30	30 – 40	40 – 50	50 – 60	60 – 70	70 – 80
Frequency	7	14	13	12	p	18	15	8

26. The median of the following data is 52.5. Find the values of x and y , if the total frequency is 100

Class Interval	0-10	10-20	20-30	30-40	40-50	50-60	60-70	70-80	80-90	90-100
Frequency	2	5	x	12	17	20	y	9	7	4

27. The mean of the following frequency distribution is 25.2. Find the missing frequency x .

Class	0 – 10	10 – 20	20 – 30	30 – 40	40 – 50
Frequency	8	x	10	11	9

28. The median of the following data is 137. Find the values of x and y , If the total frequency is 68.

Class intervals	65 – 85	85 – 105	105 – 125	125 – 145	145 – 165	165 – 185	185 – 205
Frequency	4	x	13	20	14	y	4

29. The median of the following data is 868. Find the values of x and y , if the total frequency is 100

Class	Frequency
800 – 820	7
820 – 840	14
840 – 860	x
860 – 880	25
880 – 900	y
900 – 920	10
920 – 940	5

30. The distribution below gives the marks of 100 students of a class, if the median marks are 24, find the frequencies f_1 and f_2

Marks	0-5	5-10	10-15	15-20	20-25	25-30	30-35	35-40
No. of students	4	6	10	f_1	25	f_2	18	5

31. If the median of the distribution given below is 28.5, find the values of x & y .

Class	0-10	10-20	20-30	30-40	40-50	50-60	Total
Frequency	5	x	20	15	y	5	60

MCO (1 MARK)

- For a frequency distribution, mean, median and mode are connected by the relation
 - mode = 3mean – 2median
 - mode = 2median – 3mean
 - mode = 3median – 2mean
 - mode = 3median + 2mean
- The class mark of a class interval is
 - upper limit + lower limit
 - upper limit – lower limit
 - $\frac{1}{2}$ (upper limit + lower limit)
 - $\frac{1}{2}$ (upper limit – lower limit)
- Construction of cumulative frequency table is useful in determining the
 - mode
 - median
 - mean
 - all the above three measures
- Which of the following is not a measure of central tendency of a statistical data?
 - mode
 - median
 - mean
 - range
- In a continuous frequency distribution, the median of the data is 24. If each item is increased by 2, then the new median will be
 - 24
 - 26
 - 12
 - 48
- For the following distribution

Marks	Number of students
Below 10	3
Below 20	12
Below 30	27
Below 40	57
Below 50	75
Below 60	80

the modal class is

- 10 – 20
- 20 – 30
- 30 – 40
- 40 – 50

7. For the following distribution

Marks	Number of students
Below 10	3
Below 20	12
Below 30	27
Below 40	57
Below 50	75
Below 60	80

the median class is

- 10 – 20
- 20 – 30
- 30 – 40
- 40 – 50

8. In a grouped frequency distribution, the mid values of the classes are used to measure which of the following central tendency?
 (a) mode (b) median (c) mean (d) all the above three measures

9. Weights of 40 eggs were recorded as given below:

Weights(in gms)	85 – 89	90 – 94	95 – 99	100 – 104	105- 109
No. of eggs	10	12	12	4	2

The lower limit of the median class is

- (a) 90 (b) 95 (c) 94.5 (d) 89.5

10. The median class of the following distribution is

C.I	0 – 10	10 – 20	20 – 30	30 – 40	40 – 50	50 – 60
F	8	10	12	22	30	18

- (a) 10 – 20 (b) 20 – 30 (c) 30 – 40 (d) 40 – 50

11. Weights of 40 eggs were recorded as given below:

Weights(in gms)	85 – 89	90 – 94	95 – 99	100 – 104	105- 109
No. of eggs	10	12	15	4	2

The lower limit of the modal class is

- (a) 90 (b) 95 (c) 94.5 (d) 89.5

12. In the formula $\bar{x} = a + \frac{\sum f_i d_i}{\sum f_i}$, finding the mean of the grouped data, d_i 's are deviations from

assumed mean 'a' of

- (a) lower limits of classes (b) upper limits of classes
 (c) class marks (d) frequencies of the classes.

13. In the following distribution :

Monthly income range (in Rs)	Number of families
Income more than Rs 10000	100
Income more than Rs 13000	85
Income more than Rs 16000	69
Income more than Rs 19000	50
Income more than Rs 22000	33
Income more than Rs 25000	15

the number of families having income range (in Rs) 16000 – 19000 is

- (a) 15 (b) 16 (c) 17 (d) 19

14. If x_i 's are the midpoints of the class intervals of grouped data, f_i 's are the corresponding frequencies and \bar{x} is the mean, then $\sum f_i(x_i - \bar{x})$ is equal to

- (a) 0 (b) -1 (c) 1 (d) 2

15. In the formula $\bar{x} = a + \left(\frac{\sum f_i u_i}{\sum f_i} \times h \right)$, finding the mean of the grouped data, $u_i =$

- (a) $\frac{x_i + a}{h}$ (b) $\frac{x_i - a}{h}$ (c) $\frac{a - x_i}{h}$ (d) $h(x_i - a)$

16. Construction of cumulative frequency table is useful in determining the
 (a) mean (b) median (c) mode (d) all three

17. For the following distribution:

Class	0-5	5-10	10-15	15-20	20-25
Frequency	10	15	12	20	9

The sum of lower limits of the median class and the modal class is

- (a) 15 (b) 25 (c) 30 (d) 35
18. Consider the following frequency distribution:

Class	0-9	10-19	20-29	30-39	40-49
Frequency	13	10	15	8	11

The upper limit of the median class is

- (a) 29 (b) 29.5 (c) 30 (d) 19.5

19. The abscissa of the point of intersection of the less than type and of the more than type ogives gives its

- (a) mean (b) median (c) mode (d) all three

20. For the following distribution: the modal class is

Marks	Below 10	Below 20	Below 30	Below 40	Below 50
No. of Students	8	17	32	62	80

- (a) 10 – 20 (b) 20 – 30 (c) 30 – 40 (d) 40 – 50

21. From the following data of the marks obtained by students of class X

Marks	0-10	10-20	20-30	30-40	40-50	50-60
No. of Students	8	12	20	30	10	10

How many students, secured less than 40 marks?

- (a) 70 (b) 40 (c) 80 (d) 30

22. The times in seconds taken by 150 athletics to run a 100m hurdle race are given as under:

Class	12.7-13	13-13.3	13.3-13.6	13.6-13.9	13.9-13.12
Frequency	5	6	10	55	41

The number of athletes who completed the race in less than 13.9 sec is

- (a) 21 (b) 55 (c) 41 (d) 76

23. Consider the data:

Class	25-45	45-65	65-85	85-105	105-125	125-145
Frequency	4	5	12	20	14	11

The difference of the upper limit of the median class and the lower limit of the modal class is

- (a) 0 (b) 19 (c) 20 (d) 38

24. Consider the following distribution:

Marks	Above 0	Above 10	Above 20	Above 30	Above 40	Above 50
No. of Students	63	58	55	51	48	42

The frequency of the class 30 – 40 is

- (a) 3 (b) 4 (c) 48 (d) 41

25. Consider the following frequency distribution of the heights of 60 students of a class :

Height (in cm)	Number of students
150-155	15
155-160	13
160-165	10
165-170	8
170-175	9
175-180	5

The sum of the lower limit of the modal class and upper limit of the median class is
(a) 310 (b) 315 (c) 320 (d) 330

CHAPTER – 15 PROBABILITY

PROBABILITY

The theoretical probability (also called classical probability) of an event A, written as P(A), is defined as

$$P(A) = \frac{\text{Number of outcomes favourable to A}}{\text{Number of all possible outcomes of the experiment}}$$

COMPLIMENTARY EVENTS AND PROBABILITY

We denote the event 'not E' by \bar{E} . This is called the **complement** event of event E.

So, $P(E) + P(\bar{E}) = 1$

i.e., $P(E) + P(\bar{E}) = 1$, which gives us $P(\bar{E}) = 1 - P(E)$.





















































- ☞ The probability of an event which is impossible to occur is 0. Such an event is called an **impossible event**.
- ☞ The probability of an event which is sure (or certain) to occur is 1. Such an event is called a **sure event** or a **certain event**.
- ☞ The probability of an event E is a number P(E) such that $0 \leq P(E) \leq 1$
- ☞ An event having only one outcome is called an elementary event. The sum of the probabilities of all the elementary events of an experiment is 1.

DECK OF CARDS AND PROBABILITY

A deck of playing cards consists of 52 cards which are divided into 4 suits of 13 cards each. They are black spades (♠) red hearts (♥), red diamonds (♦) and black clubs (♣).

The cards in each suit are Ace, King, Queen, Jack, 10, 9, 8, 7, 6, 5, 4, 3 and 2. Kings, Queens and Jacks are called face cards.

Example set of 52 poker playing cards

Suit	Ace	2	3	4	5	6	7	8	9	10	Jack	Queen	King
Clubs													
Diamonds													
Hearts													
Spades													

IMPORTANT QUESTIONS

- Two dice are thrown together. Find the probability that the product of the numbers on the top of the dice is (i) 6 (ii) 12 (iii) 7
- Two dice are thrown together. Find the probability that the sum of the numbers on the top of the dice is (i) 9 (ii) 10
- A die is thrown twice. What is the probability that (i) 5 will not come up either time? (ii) 5 will come up at least once?
- A lot consists of 144 ball pens of which 20 are defective and the others are good. Nuri will buy a pen if it is good, but will not buy if it is defective. The shopkeeper draws one pen at random and gives it to her. What is the probability that (i) She will buy it ? (ii) She will not buy it ?
- One card is drawn from a well-shuffled deck of 52 cards. Find the probability of getting (i) red colour ace card (ii) a face card or a spade card (iii) a black face card
- One card is drawn from a well-shuffled deck of 52 cards. Find the probability of getting (i) a king of red colour (ii) a face card (iii) a red face card (iv) the jack of hearts (v) a spade (vi) the queen of diamonds
- 12 defective pens are accidentally mixed with 132 good ones. It is not possible to just look at a pen and tell whether or not it is defective. One pen is taken out at random from this lot. Determine the probability that the pen taken out is a good one.
- A piggy bank contains hundred 50p coins, fifty Re 1 coins, twenty Rs 2 coins and ten Rs 5 coins. If it is equally likely that one of the coins will fall out when the bank is turned upside down, what is the probability that the coin (i) will be a 50 p coin ? (ii) will not be a Rs 5 coin?
- A box contains 5 red marbles, 8 white marbles and 4 green marbles. One marble is taken out of the box at random. What is the probability that the marble taken out will be (i) red ? (ii) white ? (iii) not green?
- (i) A lot of 20 bulbs contain 4 defective ones. One bulb is drawn at random from the lot. What is the probability that this bulb is defective?
(ii) Suppose the bulb drawn in (i) is not defective and is not replaced. Now one bulb is drawn at random from the rest. What is the probability that this bulb is not defective ?
- A box contains 90 discs which are numbered from 1 to 90. If one disc is drawn at random from the box, find the probability that it bears (i) a two-digit number (ii) a perfect square number (iii) a number divisible by 5.
- A carton consists of 100 shirts of which 88 are good, 8 have minor defects and 4 have major defects. Jimmy, a trader, will only accept the shirts which are good, but Sujatha, another trader, will only reject the shirts which have major defects. One shirt is drawn at random from the carton. What is the probability that (i) it is acceptable to Jimmy? (ii) it is acceptable to Sujatha?

13. Two customers are visiting a particular shop in the same week (Monday to Saturday). Each is equally likely to visit the shop on any day as on another day. What is the probability that both will visit the shop on (i) the same day? (ii) consecutive days? (iii) different days?
14. A bag contains 5 red balls and some blue balls. If the probability of drawing a blue ball is *double* that of a red ball, determine the number of blue balls in the bag.
15. A box contains 12 balls out of which x are black. If one ball is drawn at random from the box, what is the probability that it will be a black ball? If 6 more black balls are put in the box, the probability of drawing a black ball is now double of what it was before. Find x .
16. A jar contains 24 marbles, some are green and others are blue. If a marble is drawn at random from the jar, the probability that it is green is $\frac{2}{3}$. Find the number of blue marbles in the jar.
17. A bag contains 5 red, 4 blue and 3 green balls. A ball is taken out of the bag at random. Find the probability that the selected ball is (i) of red colour (ii) not of green colour.
18. A card is drawn at random from a well-shuffled deck of playing cards. Find the probability of drawing a (i) face card (ii) card which is neither a king nor a red card (iii) neither an ace nor a king card (iv) a king or a jack (v) a non-ace (vi) a red card (vii) neither a king nor a queen
19. 15 cards, numbered 1, 2, 3, ..., 15 are put in a box and mixed thoroughly. A card is drawn at random from the box. Find the probability that the card drawn bears (i) an even number (ii) a number divisible by 2 or 3.
20. Cards, marked with numbers 5 to 50, are placed in a box and mixed thoroughly. A card is drawn from the box at random. Find the probability that the number on the taken card is (i) a prime number less than 10. (ii) a number which is a perfect square.
21. Find the probability of getting 53 Fridays in a leap year.
22. Two coins are tossed simultaneously. What is the probability of getting (i) At least one head? (ii) At most one tail? (iii) A head and a tail?
23. The king, queen and jack of diamonds are removed from a pack of 52 cards and then the pack is well shuffled. A card is drawn from the remaining cards. Find the probability of getting a card of (i) diamonds, (ii) a jack
24. Three cards of spades are lost from a pack of 52 playing cards. The remaining cards were well shuffled and then a card was drawn at random from them. Find the probability that the drawn cards are of black colour.
25. Two different dice are tossed together. Find the probability (i) that the number on each dice is even (ii) that the sum of numbers appearing on two dice is 5.
26. Cards marked with numbers 3, 4, 5, ..., 50 are placed in a box and mixed thoroughly. One card is drawn at random from the box. Find the probability that number on the drawn card is (i) divisible by 7 (ii) a number which is a perfect square.
27. Cards bearing numbers 1, 3, 5,, 35 are kept in a bag. A card is drawn at random from the bag. Find the probability of getting a card bearing (a) a prime number less than 15. (b) a number divisible by 3 and 5.
28. Two dice are rolled once. Find the probability of getting such numbers on the two dice, whose product is 12.
29. A bag contains 5 white balls, 7 red balls, 4 black balls and 2 blue balls. One ball is drawn at random from the bag. What is the probability that the ball drawn is (i) white or blue (ii) red or black (iii) not white (iv) neither white nor black.
30. A box contains 19 balls bearing numbers 1, 2, 3, ..., 19. A ball is drawn at random from the box. What is the probability that the number on the ball is (i) a prime number (ii) divisible by 3 or 5 (iii) neither divisible by 5 nor by 10 (iv) an even number.

4. What is the probability of getting a number 5?
(a) 1 (b) 0 (c) $\frac{1}{25}$ (d) $\frac{1}{5}$
5. What is the probability of getting a number less than 11?
(a) 1 (b) 0 (c) $\frac{1}{5}$ (d) $\frac{2}{5}$
6. What is the probability of getting a number greater than 25?
(a) 1 (b) 0 (c) $\frac{1}{5}$ (d) $\frac{2}{5}$
7. What is the probability of getting a multiple of 5?
(a) 1 (b) 0 (c) $\frac{1}{25}$ (d) $\frac{1}{5}$
8. What is the probability of getting an even number?
(a) 1 (b) 0 (c) $\frac{12}{25}$ (d) $\frac{13}{25}$
9. What is the probability of getting an odd number?
(a) 1 (b) 0 (c) $\frac{12}{25}$ (d) $\frac{13}{25}$
10. What is the probability of getting a prime number?
(a) $\frac{8}{25}$ (b) $\frac{9}{25}$ (c) $\frac{12}{25}$ (d) $\frac{13}{25}$
11. What is the probability of getting a number divisible by 3?
(a) $\frac{8}{25}$ (b) $\frac{9}{25}$ (c) $\frac{12}{25}$ (d) $\frac{13}{25}$
12. What is the probability of getting a number divisible by 4?
(a) $\frac{8}{25}$ (b) $\frac{9}{25}$ (c) $\frac{6}{25}$ (d) $\frac{3}{25}$
13. What is the probability of getting a number divisible by 7?
(a) $\frac{8}{25}$ (b) $\frac{9}{25}$ (c) $\frac{6}{25}$ (d) $\frac{3}{25}$
14. A bag has 4 red balls and 2 yellow balls. A ball is drawn from the bag without looking into the bag. What is probability of getting a red ball?
(a) $\frac{1}{6}$ (b) $\frac{2}{3}$ (c) $\frac{1}{3}$ (d) 1
15. A bag has 4 red balls and 2 yellow balls. A ball is drawn from the bag without looking into the bag. What is probability of getting a yellow ball?

(a) $\frac{1}{6}$

(b) $\frac{2}{3}$

(c) $\frac{1}{3}$

(d) 1

One card is drawn from a well-shuffled deck of 52 cards. Answer the question from 1 to 12.

16. Find the probability of getting a king of red colour

(a) $\frac{1}{26}$

(b) $\frac{2}{13}$

(c) $\frac{1}{13}$

(d) $\frac{3}{26}$

17. Find the probability of getting a face card.

(a) $\frac{1}{26}$

(b) $\frac{2}{13}$

(c) $\frac{1}{13}$

(d) $\frac{3}{13}$

18. Find the probability of getting a black face card

(a) $\frac{1}{26}$

(b) $\frac{2}{13}$

(c) $\frac{1}{13}$

(d) $\frac{3}{26}$

19. Find the probability of getting an ace.

(a) $\frac{1}{26}$

(b) $\frac{2}{13}$

(c) $\frac{1}{13}$

(d) $\frac{3}{26}$

20. Find the probability of getting a black card.

(a) $\frac{1}{2}$

(b) $\frac{2}{13}$

(c) $\frac{1}{13}$

(d) $\frac{3}{26}$

21. Find the probability of getting a face card or an ace.

(a) $\frac{4}{13}$

(b) $\frac{2}{13}$

(c) $\frac{1}{13}$

(d) $\frac{3}{13}$

22. Find the probability of getting face card or black card.

(a) $\frac{4}{13}$

(b) $\frac{8}{13}$

(c) $\frac{7}{13}$

(d) $\frac{3}{13}$

23. Find the probability of getting a king or red card.

(a) $\frac{4}{13}$

(b) $\frac{8}{13}$

(c) $\frac{7}{13}$

(d) $\frac{3}{13}$

24. Find the probability of getting a king and red card.

(a) $\frac{1}{26}$

(b) $\frac{2}{13}$

(c) $\frac{1}{13}$

(d) $\frac{3}{26}$

25. Find the probability of getting a king or queen card.

(a) $\frac{1}{26}$

(b) $\frac{2}{13}$

(c) $\frac{1}{13}$

(d) $\frac{3}{26}$