

SCIENCE

(Physics)

Chapter 12: Electricity

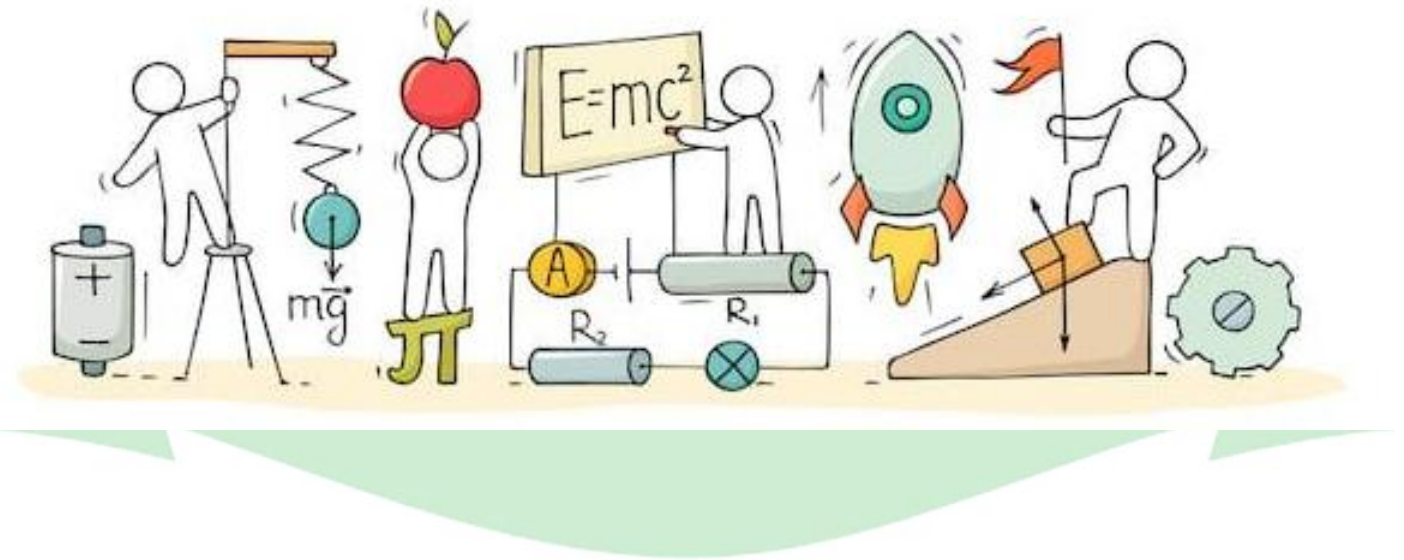

Electricity

Electric Current

- **Electric current** is expressed as the amount of charge flowing through a particular area in unit time.
- Quantitatively, **electric current** is defined as the rate of flow of electric charge.

$$\text{Current, } I = \frac{\text{Charge flowing (Q)}}{\text{Time taken (t)}}$$

- The S.I. unit of current is **ampere (A)**, where 1 ampere = 1 coulomb/second.
- $1 \text{ mA} = 10^{-3} \text{ A}$, $1 \mu\text{A} = 10^{-6} \text{ A}$
- The conventional direction of electric current is the one in which positive charges move orderly.
- An instrument called ammeter measures electric current in a circuit. It is always connected in series in a circuit through which the current is to be measured.

Electric circuit and circuit diagram

The electric circuits are closed loop or path which forms a network of electrical components, where electrons are able to flow. This path is made using electrical wires and is powered by a source, like a battery. The start of the point from where the electrons start flowing is called the source whereas the point where electrons leave the electrical circuit is called the return. Representation of an electric circuit through symbols is called a circuit diagram.

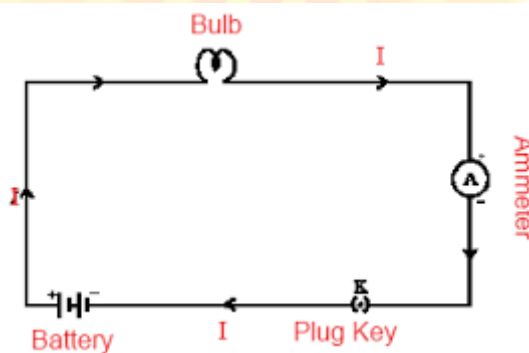

A schematic diagram of an electric circuit comprising – cell, electric bulb, ammeter and plug key

Example: A current of 1A is drawn by a filament of an electric bulb for 20 minutes. Find the amount of electric charge that flows through the circuit.

Ans:

The given data is,

$I = 1\text{A}$ and

$t = 20$ minutes

$t = 20 \times 60$

$t = 1200$ seconds

Therefore,

$$I = \frac{Q}{t}$$

Electric charge is $q = It$

$$q = 1 \times 1200$$

$$q = 1200 \text{ C}$$

Coulomb's Law

According to Coulomb's law, the force of attraction or repulsion between two charged bodies is directly proportional to the product of their charges and inversely proportional to the square of the distance between them. It acts along the line joining the two charges considered to be point charges. $F \propto \frac{q_1 q_2}{d^2}$

Electric Potential

Electric potential is the work done per unit charge in bringing the charge from infinity to that point against electrostatic force. In a conductor, electrons flow only when there is a difference in electric pressure at its ends. This is also called potential difference.

Electric Potential Different

- Electric potential difference (pd) between two points in an electric circuit, carrying some current, is the amount of work done to move a unit charge from one point to another.

$$\text{Potential difference (pd)} = \frac{\text{Work done (W)}}{\text{Quantity of charge moved (Q)}}$$

- The S.I. unit of pd is **volt (V)**, where $1 \text{ volt} = \frac{1 \text{ joule}}{1 \text{ coulomb}}$

Example: How much work is done in moving a charge of 2 C across two points having a potential difference 12 V?

Ans:

The amount of charge Q, that flows between two points at potential difference V (= 12 V) is 2 C. Thus, the amount of work W, done in moving the charge [from Eq. (12.2)] is

$$W = VQ$$









$$= 12 \text{ V} \times 2 \text{ C}$$

$$= 24 \text{ J.}$$

Electric Circuit

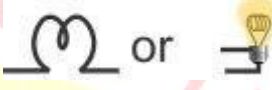
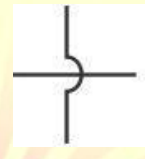
- A continuous conducting path between the terminals of a source of electricity is called an **electric circuit**.
- A drawing showing the way various electric devices are connected in a circuit is called a **circuit diagram**.
- Some commonly used circuit elements are given below:

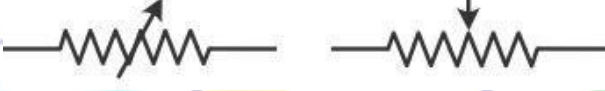
Sr. No.	Element	Symbol
1	An electric cell	

2	A battery	
3	Plug key or switch (open)	
4	Plug key or switch (closed)	
5	A wire joint	
7	Bulb	
6	Wires crossing without joining	
8	Resistor	
9	Variable resistor or Rheostat	
10	Ammeter	
11	Voltmeter	

Ohm's law

- According to Ohm's law, the current (I) flowing through a conductor is directly proportional to the potential difference (V) across its ends, provided its physical conditions remain the same.

$$V \propto I$$

$$\frac{V}{I} = \text{Constant}$$

$$\frac{V}{I} = R$$

$$V = IR$$

where R is a constant of proportionality called **resistance** of the conductor.

- Resistance** is the property of a conductor to resist the flow of charges through it.
- The S.I. unit of resistance is **ohm (Ω)**.

$$\text{From } R \propto \frac{V}{I} \quad 1 \text{ ohm} = 1 \frac{\text{volt}}{\text{ampere}}$$

Potential difference across the two points of a metallic conductor is directly proportional to current passing through the circuit provided that temperature remains constant.

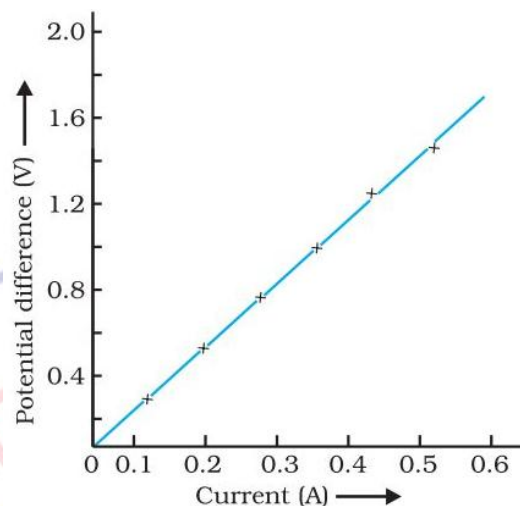

V-I graph for a nichrome wire. A straight line plot shows that as the current through a wire increases, the potential difference across the wire increases linearly – this is Ohm's law.

Factors Affecting Resistance

A conducting wire's resistance is determined by:

- Nature of the material of the wire [Resistivity (Ω)]
- Length of the wire (l)
- Cross-sectional area of the wire (A)

Factors on which the Resistance of a Conductor depends

Resistance of a uniform metallic conductor is:

- directly proportional to the length of conductor,
- inversely proportional to the area of cross-section,
- directly proportional to the temperature and
- depend on nature of material.

Resistivity

- The resistance of a conductor is directly proportional to its length (l) and inversely proportional to its area of cross section (A).

$$R \propto \frac{l}{A}$$

$$R = \rho \frac{l}{A}$$

where ρ is a constant of proportionality called **specific resistance** or **resistivity** of the material of the conductor.

- The S.I. unit of resistivity is **ohm metre ($\Omega \text{ m}$)**.
- Resistivity does not change with change in length or area of cross-section but it changes with change in temperature.

- Range of resistivity of metals and alloys is 10^{-8} to $10^{-6} \Omega\text{m}$.
- Range of resistivity of insulators is 10^{12} to $10^{17} \Omega\text{m}$.
- Resistivity of alloy is generally higher than that of its constituent metals.
- Alloys do not oxidize (burn) readily at high temperature, so they are commonly used in electrical heating devices.
- Copper and aluminum are used for electrical transmission lines as they have low resistivity.

Semiconductors and Superconductors

- **Semiconductors** are materials with resistivity that fall between those of an insulator and a conductor.
- Materials which lose their resistivity at low temperatures are called **super conductors**.

Combination of Resistances

Resistances in Series

- The current flowing through each resistance is the same.
- The potential difference across the ends of the series combination is distributed across the resistances.
- The equivalent resistance (R_s) of a series combination containing resistances R_1, R_2, R_3, \dots is $R_s = R_1 + R_2 + R_3 + \dots$
- The equivalent resistance is greater than the greatest resistance in the combination.

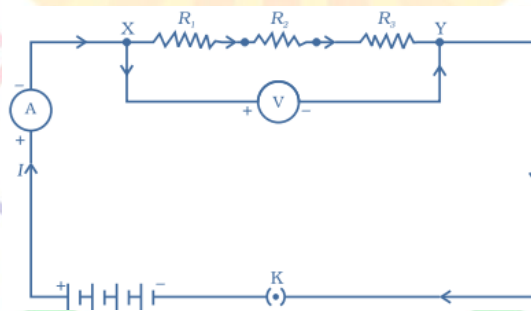

Resistances in Parallel

- The potential difference across each resistance is the same and is equal to the potential difference across the combination.
- The main current divides itself, and a different current flows through each resistance.
- The equivalent resistance (R_p) of a parallel combination containing resistances R_1, R_2, R_3, \dots is given by $\frac{1}{R_p} = \frac{1}{R_1} + \frac{1}{R_2} + \frac{1}{R_3} + \frac{1}{R_4} + \dots =$
- The equivalent resistance is lesser than the least of all the resistances in the combination.

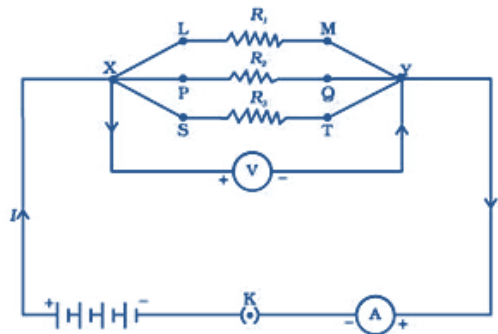

Advantages of Parallel Combination over Series Combination

- In series circuit, when one component fails, the circuit is broken and none of the component works.
- Different appliances have different requirement of current. This cannot be satisfied in series as current remains same.
- The total resistance in a parallel circuit is decreased.

Heating Effect of Electric Current

- The effect of electric current due to which heat is produced in a conductor, when current passes through it, is called the heating effect of electric current.
- The total work (W) done by the current in an electric circuit is called **electric energy** and is given as

$$W = VIt = I^2Rt$$

$$W = \frac{V^2t}{R}$$

This energy is exhibited as heat. Thus, we have $H = VIt = I^2Rt$.

This is called **Joule's Law of Heating**, which states that the heat produced in a resistor is directly proportional to the:

- Square of the current in the resistor, $H \propto I^2$
- Resistance of the resistor $H \propto R$
- Time for which current flows through the conductor, $H \propto t$. So, $H = I^2Rt$
- Heating effect is desirable in devices like electric heater, electric iron, electric bulb, electric fuse, etc.
- Heating effect is undesirable in devices like computers, computer monitors (CRT), TV, refrigerators etc.
- In electric bulb, most of the power consumed by the filament appears a heat and a small part of it is radiated in form of light.

Filament of electric bulb is made up of tungsten because:

- it does not oxidize readily at high temperature.
- it has high melting point (3380°C).

The bulbs are filled with chemically inactive gases like nitrogen and argon to prolong the life of filament.

Practical Applications of the Heating Effects of Electric Current

- Electrical appliances like laundry iron, toaster, oven, kettle and heater are some devices based on Joule's Law of Heating.
- The concept of electric heating is also used to produce light, as in an electric bulb.
- Another application of Joule's Law of Heating is the fuse used in electric circuits.

Electric Fuse

It is a safety device that protects our electrical appliances in case of short circuit or overloading.

- Fuse is made up of pure tin or alloy of copper and tin.
- Fuse is always connected in series with live wire.
- Fuse has low melting point.
- Current capacity of fuse is slightly higher than that of the appliance.

Electric Power

- Electric power is the rate at which electrical energy is produced or consumed in an electric circuit

$$P = VI = I^2R$$

$$P = \frac{V^2}{R}$$

- The **S.I. unit** of power is **watt (W)**.
- One watt of power is consumed when 1 A of current flows at a potential difference of 1 V. The commercial unit of electric energy is **kilowatt hour (kWh)**, commonly known as a **unit**. **1 kWh = 3.6 MJ**

Class : 10th Physics
Chapter-12 : Electricity

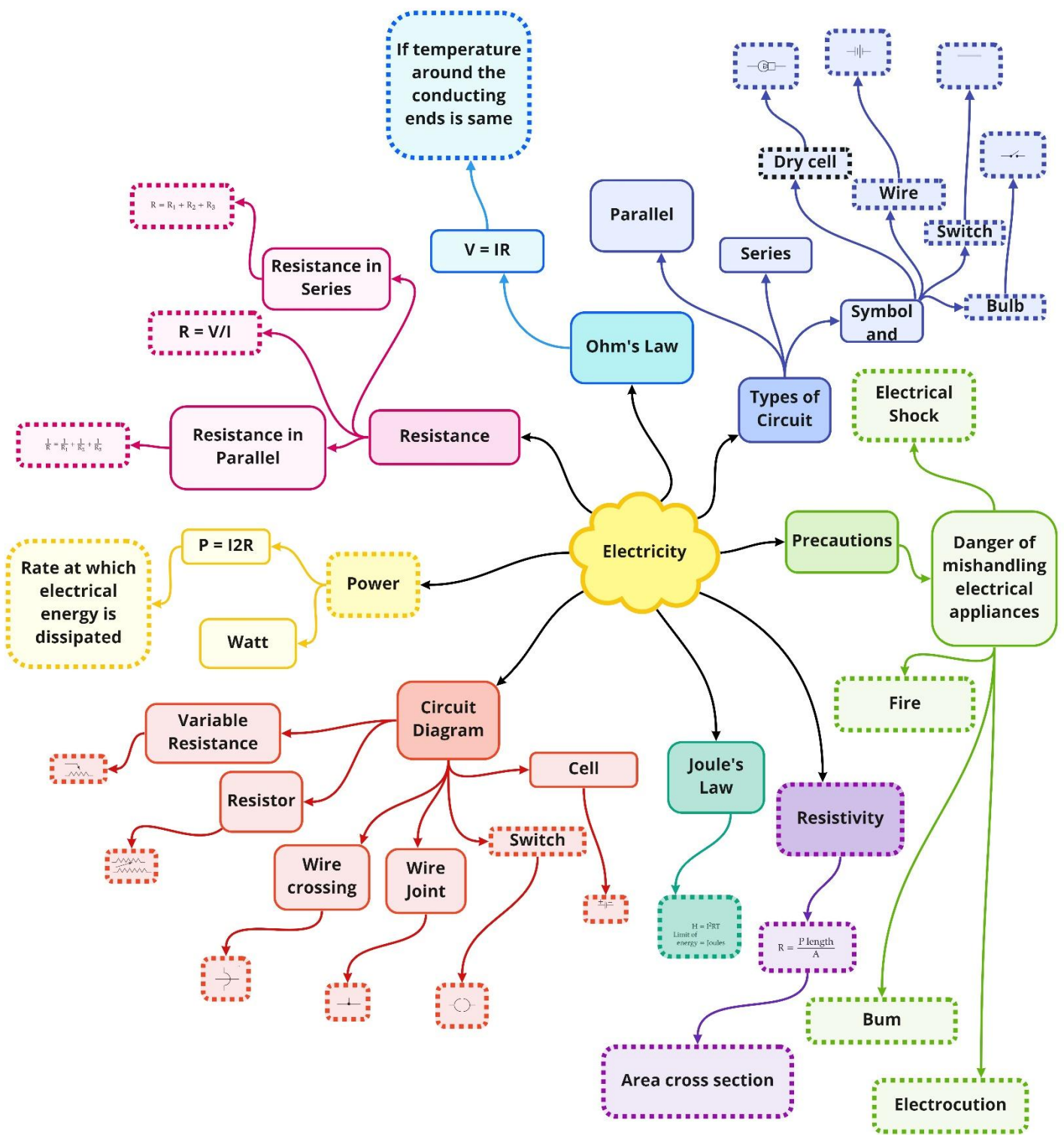

Important Questions

Multiple Choice Questions:

Which of the following represents voltage?

(a) $\frac{\text{Work done}}{\text{Current} \times \text{Charge}}$

(b) $\text{Work done} \times \text{Charge}$

(c) $\frac{\text{Work done} \times \text{Time}}{\text{Current}}$

(d) $\text{Work done} \times \text{Charge} \times \text{Time}$

2. Unit of electric power may also be expressed as

- (a) volt ampere
- (b) kilowatt hour
- (c) watt second
- (d) Joule second

3. Electrical resistivity of a given metallic wire depends upon

- (a) its length
- (b) its thickness
- (c) its shape
- (d) nature of the material

4. A cell, a resistor, a key and ammeter are arranged as shown in the circuit diagrams of Figure (i), (ii) and (iii). The current recorded in the ammeter will be

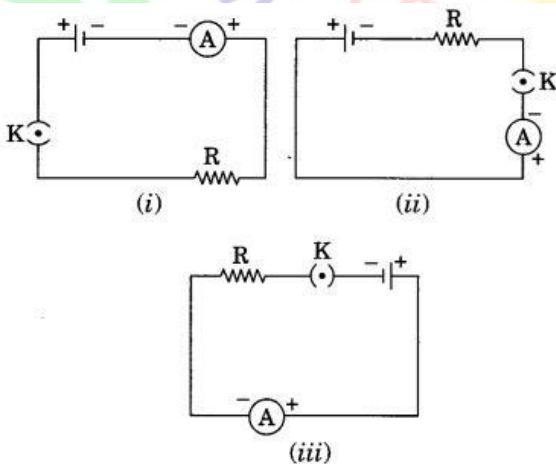

- (a) maximum in (i)
 - (b) maximum in (ii)
 - (c) maximum in (iii)
 - (d) the same in all the cases
5. The unit of e.m.f. of a cell is
- (a) dyne

- (b) volt
(c) ampere
(d) joule
6. Kilowatt hour is the unit of
(a) power
(b) energy
(c) impulse
(d) force
7. 1 kWh is equal to
(a) 3.6×10^6 MJ
(b) 3.6×10^5 MJ
(c) 3.6×10^2 MJ
(d) 3.6 MJ
8. Materials which allow larger currents to flow through them are called
(a) insulators
(b) conductors
(c) semiconductors
(d) alloys
9. Conventionally, the direction of the current is taken as
(a) the direction of flow of negative charge
(b) the direction of flow of atoms
(c) the direction of flow of molecules
(d) the direction of flow of positive charge
10. The unit of specific resistance is
(a) ohm
(b) ohm
(c) ohm-meter
(d) ohm per meter

Very Short Question:

1. Define electric potential.
2. State the relation between work (W), charge (q) and electric potential (V).
3. What is the S.I. unit of electrical potential?

4. Define 1 volt electric potential.
5. Is electric potential a scalar or a vector physical quantity?
6. What is meant by potential difference between two points?
7. Name the instrument used to measure the electric potential difference.
8. Write down the relation between the potential difference between two points A and B in a conductor, work done W in moving a unit charge from point B to A and the charge q .

Or

State the relation between work, charge and potential difference for an electric circuit.

Or

Express work done in an electric field in terms of charge and potential difference.

9. Mention the factor that maintains the flow of charge through a conductor.
10. Define electric current.

Short Questions:

1. Define electric current. State and define its SI unit.
2. List two differences between a voltmeter and ammeter.
3. What is an electric circuit? Distinguish between an open and a closed circuit.
4. What do the following symbols represent in a circuit? Write the name and one function of each.

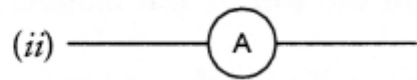

5. What do the following symbols represent in a circuit? Write the name and one function of each?

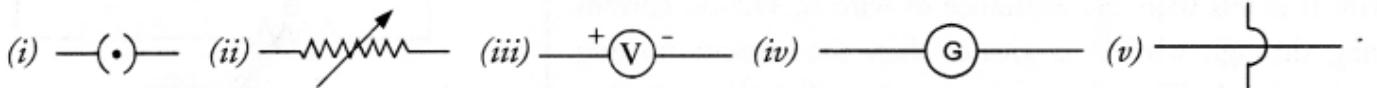

6. Express Ohm's law both by a mathematical formula and by a graph line.
7. List the factors on which the resistance of a conductor depends. Write the expression to show the relation of resistance with these factors.
8. What is likely to happen and how it would affect the value of resistance if we pass the current for a longer time?

Long Questions:

1. State Ohm's law. How can this law be verified experimentally? Does Ohm's law hold good under all conditions?
2. How will you infer with the help of an experiment that same voltage or potential

difference exists across three resistors connected in parallel arrangement to a battery?

Assertion Reason Questions:

- For two statements are given-one labelled Assertion (A) and the other labelled Reason (R). Select the correct answer to these questions from the codes (a), (b), (c) and (d) as given below:
 - Both A and R are true, and R is correct explanation of the assertion.
 - Both A and R are true, but R is not the correct explanation of the assertion.
 - A is true, but R is false.
 - A is false, but R is true.

Assertion: A current carrying wire should be charged.

Reason: The current in a wire is due to flow of free electrons in a definite direction.

- For two statements are given-one labelled Assertion (A) and the other labelled Reason (R). Select the correct answer to these questions from the codes (a), (b), (c) and (d) as given below:
 - Both A and R are true, and R is correct explanation of the assertion.
 - Both A and R are true, but R is not the correct explanation of the assertion.
 - A is true, but R is false.
 - A is false, but R is true.

Assertion: Good conductors of heat are also good conductors of electricity and vice versa.

Reason: Mainly electrons are responsible for conduction.

Case Study Questions:

- Read the following and answer any four questions from (i) to (v).

The rate of flow of charge is called electric current. The SI unit of electric current is Ampere (A). The direction of flow of current is always opposite to the direction of flow of electrons in the current. The electric potential is defined as the amount of work done in bringing a unit positive test charge from infinity to a point in the electric field. The amount of work done in bringing a unit positive test charge from one point to another point in an electric field is defined as potential difference.

$$V_{AB} = V_B - V_A = \frac{W_{BA}}{q}$$

The SI unit of potential and potential difference is volt.

- The 2C of charge is flowing through a conductor in 100ms, the current in the circuit is:

- a. 20A
b. 2A
c. 0.2A
d. 0.02A
- ii. Which of the following is true?
- a. Current flows from positive terminal of the cell to the negative terminal of the cell outside the cell.
b. The negative charge moves from lower potential to higher potential.
c. The direction of flow of current is same as the direction of flow of positive charge.
d. All of these.
- iii. The potential difference between the two terminals of battery, if 100 joules of work is required to transfer 20 coulombs of charge from one terminal of the battery to other is:
- a. 50V
b. -5V
c. 0.5V
d. 500V
- iv. The number of electrons flowing per second in a conductor if 1 A current is passing through it:
- a. 6.25×10^{20}
b. 6.25×10^{19}
c. 6.25×10^{18}
d. 6.25×10^{-19}
- v. The voltage can be written as:
- a. Work done \times charge \times time
b. $\frac{\text{Work done}}{\text{Current} \times \text{time}}$
c. $\frac{\text{Work done} \times \text{time}}{\text{Current}}$
d. Work done \times charge

2. Read the following and answer any four questions from (i) to (v).

The electrical energy consumed by an electrical appliance is given by the product of its power rating and the time for which it is used. The SI unit of electrical

energy is Joule. Actually, Joule represents a very small quantity of energy, and therefore it is inconvenient to use where a large quantity of energy is involved. So, for commercial purposes we use a bigger unit of electrical energy which is called kilowatt-hour. 1 kilowatt-hour is equal to 3.6×10^6 joules of electrical energy.

- i. The energy dissipated by the heater is E. When the time of operating the heater is doubled, the energy dissipated is:
 - a. Doubled
 - b. Half
 - c. Remains same
 - d. Four times
- ii. The power of a lamp is 60W. The energy consumed in 1 minute is:
 - a. 360J
 - b. 36J
 - c. 3600J
 - d. 3.6J
- iii. The electrical refrigerator rated 400W operates 8 hours a day. The cost of electrical energy is ₹ 5 per kWh. Find the cost of running the refrigerator for one day?
 - a. ₹ 32
 - b. ₹ 16
 - c. ₹ 8
 - d. ₹ 4
- iv. Calculate the energy transformed by a 5A current flowing through a resistor of 2Ω for 30 minutes?
 - a. 90kJ
 - b. 80kJ
 - c. 60kJ
 - d. 40kJ
- v. Which of the following is correct?
 - a. 1 watt hour = 3600J
 - b. 1 kWh = 36×10^6 J
 - c. Energy (in kWh) = power (in W) \times time (in hr)
 - d. Energy (in kWh) = $\frac{V(\text{volt}) \times I(\text{ampere}) \times t(\text{sec})}{100}$

✓ Answer Key-

☐ Multiple Choice Answers:

1. (a)
2. (a) volt ampere
3. (d) nature of the material
4. (d) the same in all the cases
5. (b) volt
6. (b) energy
7. (d) 3.6 MJ
8. (b) conductors
9. (d) the direction of flow of positive charge
10. (c) ohm-meter

☐ Very Short Answers:

1. Answer: Electric potential at a point in an electric field is defined as the work done in moving a unit positive charge from infinity to that point in the electric field.
2. Answer: $V = W/q$.
3. Answer: volt.
4. Answer: Electric potential is said to be 1 volt if 1 Joule of work is done in moving 1 coulomb charge from infinity to a point in the electric field.
5. Answer: Electric potential is a scalar physical quantity.
6. Answer: Work done per unit charge in moving a unit positive charge from one point to another point in an electric field is called potential difference between two points.
7. Answer: Voltmeter.
8. Answer:

$$V_A - V_B = dV = \frac{W}{q}. \quad \text{That is, potential difference} = \frac{\text{Work}}{\text{Charge}}$$

9. Answer: Potential difference across the ends of the conductor.
10. Answer: Electric current is defined as the amount of electric charge flowing through any cross-section of a conductor per unit time.

☐ Short Answers:

1. Answer: Electric current is defined as the amount of charge flowing through a cross-section of a conductor in unit time.

$$I = \frac{\text{Charge}}{\text{Time}} = \frac{Q}{t}$$

SI unit of electric current is ampere (A).

Electric current through a conductor is said to be 1 ampere if one coulomb charge flows through a cross-section of the conductor in one second.

2. Answer:

Ammeter	Voltmeter
<ol style="list-style-type: none"> 1. Ammeter measures electric current in the circuit. 2. Ammeter is connected in series in an electric circuit. 	<ol style="list-style-type: none"> 1. Voltmeter measures the potential difference between two points on a conductor. 2. Voltmeter is connected in parallel across the ends of a conductor or resistor.

3. Answer: electric circuit:

An electric circuit is a closed conducting path containing a source of electric energy (i.e., a cell or a battery) and a device or element or load (say, an electric bulb) utilizing the electric energy.

The direction of electric current is opposite to the direction of the flow of electrons in the conductor.

Open electric circuit: An electric circuit through which no electric current flows is known as open electric circuit.

The electric circuit shown in figure 10 (A) will be open circuit if the plug of the key is taken out or if the connecting wire breaks from any point.

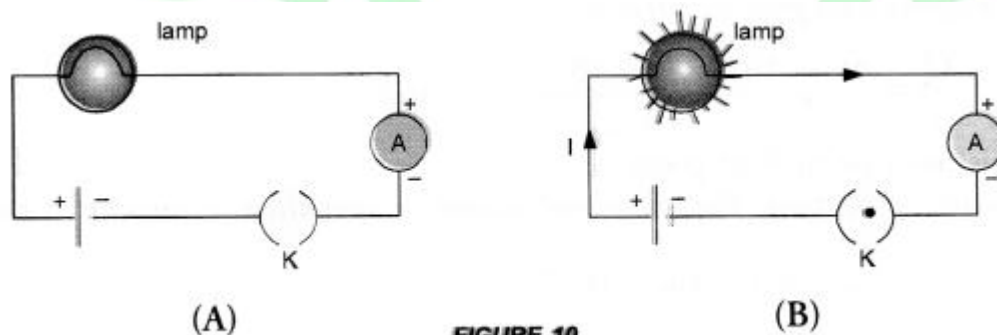

Closed circuit: An electric circuit through which electric current flows continuously is known as closed circuit (Figure 10 (B)).

4. Answer:

(i) It represents a battery. It maintains a potential difference across the circuit

element for the flow of current in the circuit.

(ii) It represents an ammeter. Ammeter is used to measure the electric current in the circuit.

5. Answer:

(i) It represents a closed plug key. It is used to make the closed electric circuit.

(ii) It represents a variable resistance. It is used to increase or decrease the electric current in the circuit.

(iii) It represents a voltmeter. It is used to measure the potential difference across a resistor in the circuit.

(iv) It represents a galvanometer. It is used to detect the presence of small current in the circuit.

(v) It represents wire crossing (not connected with each other). The wires are used to connect various components in the circuit.

6. Answer:

Mathematical formula of Ohm's law is

$$V = IR$$

For a graph line,

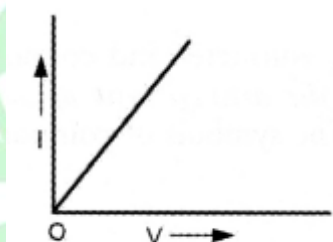

FIGURE 11

7. Answer: Resistance of a factor depends on its length (l) and area of cross section (A).

8. Answer: When current passes through a conductor for a longer time, the conductor is heated due to Joule's heating effect. Resistance of conductor increases with increase in temperature due to heating effect.

Long Answers:

1. Answer:

For Ohm's law: Ohm's law states that the electric current flowing through a conductor is directly proportional to the potential difference across the ends of the conductor, provided the temperature and other physical conditions of the conductor remain the same.

For experimental verification: Verify Ohm's law

Apparatus: A conductor of resistance R , an ammeter, a voltmeter, a battery, a

variable resistance (or rheostat used to change the current in the circuit), connecting wires, a key and sand paper.

Procedure:

- Connect the various components as shown in figure 12.

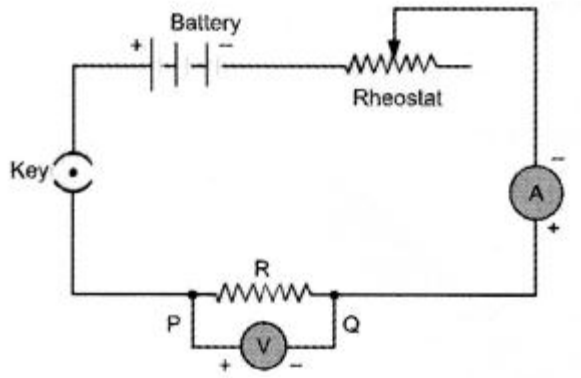

FIGURE 12

- Close the key, so that current begins to flow in the circuit.
- Note down the potential difference (V) across the conductor PQ of resistance R shown by the voltmeter and the corresponding current (I) shown by the ammeter.
- Now move the knob of rheostat so that the current in the circuit increases.
- Again note down the potential difference (V) across the conductor PQ of resistance R in the voltmeter and current in the circuit shown by ammeter.
- Repeat the experiment at least five times by increasing the current in the circuit by moving the knob of the rheostat in steps.

Observations:

S.No	Potential Difference (V)	Current (I)	V/I
1.			
2.			
3.			
4.			
5.			
6.			
7.			

Plot a graph between V and I by taking V along X-axis and I along Y-axis. We get a straight line passing through origin as shown in figure 11.

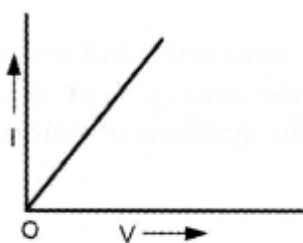

FIGURE 11

Conclusion: From the graph between V and I, we conclude that $I \propto V$, which is Ohm's law. Hence Ohm's law is verified experimentally.

Precautions: While verifying Ohm's law experimentally, the following precautions should be taken:

- Current should not be allowed to pass through the circuit continuously for a long time, which may cause the increase in temperature of the conductor. Therefore, the plug of the key must be taken out every time

after noting the readings of ammeter and voltmeter.

- Connections should be tight.
- The conductor used in the experiment should be such that its resistance is not changed with increase in temperature of the conductor.

Ohm's law holds good if the temperature of the conductor remains the same.

2. Answer:

Perform an activity to investigate the relation between potential difference across parallel combination of resistors and the potential difference across each individual resistors,

- Connect three resistors of resistances R_1 , R_2 and R_3 in parallel. One end of each resistor is joined at a common point 'a' and the other end of each resistor is connected at another common point 'b'.
- Connect the parallel combination of resistors with a battery, a plug key K and an ammeter A as shown in figure 22(A).

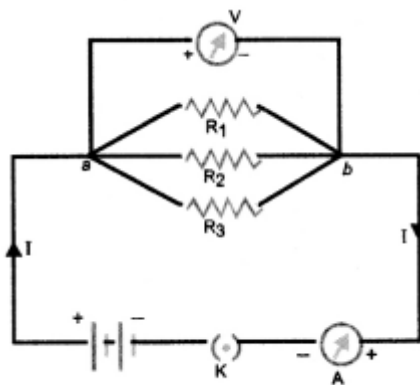

FIGURE 22(A)

- Now connect a voltmeter across the parallel combination of resistors between a and b points.
- Note the reading of voltmeter. Let it be V . This is the potential difference across the parallel combination of resistors.
- Now, disconnect the voltmeter and connect it across R_1 as shown in figure 22(B).

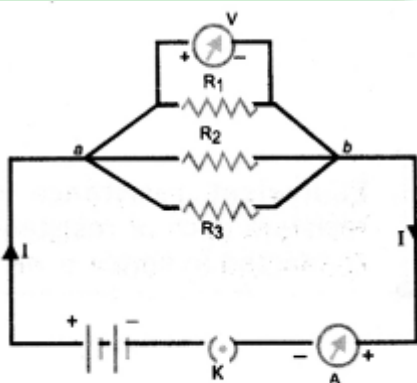

FIGURE 22(B)

- Note the reading of voltmeter. It is found to be V .

- Disconnect the voltmeter and connect it across R_2 . Note the reading of voltmeter. It is found to be V .
- Again, disconnect the voltmeter and connect it across R_3 . Note the reading of voltmeter. It is found to be V .

Conclusion : When resistors are connected in parallel to each other, potential difference across each resistor is equal to the potential difference across the parallel combination of resistors.

❓ Assertion Reason Answer:

1. (d) A is false, but R is true.

Explanation:

The current in a wire is due to flow of free electrons in a definite direction. But the number of protons in the wire at any instant is equal to number of electrons, and charge on electrons is equal and opposite to that of proton. Hence, net charge on the wire is zero.

2. (a) Both A and R are true, and R is correct explanation of the assertion.

Explanation:

Metals are good conductors of electricity. It is because of the presence of a large number of free electrons in metals. And for metals, electrons are the main cause for thermal conduction. That's why all good conductors of heat are also good conductors of electricity.

❓ Case study Answer:

1.
 - i. (a) 20 A

Explanation:

$$q = 2C, t = 100\text{ms} = 0.1\text{s}$$

$$I = \frac{q}{t} = \frac{2}{0.1} = 20\text{A}$$

- ii. (d) All of these.
- iii. (b) -5V

Explanation:

$$W = 100\text{J}, q = 20\text{C}$$

$$V = \frac{W}{q} = \frac{100}{20} = 5\text{V}$$

iv. (c) 6.25×10^{18}

Explanation:

$$I = 1\text{A}, t = 1\text{s}$$

$$q = It = 1 \times 1 = 1\text{C}$$

$$n = \frac{q}{e} = \frac{1}{1.6 \times 10^{-19}} = 6.25 \times 10^{18}$$

v. (c) $\frac{\text{Work done} \times \text{time}}{\text{Current}}$

Explanation:

$$V = \frac{W}{q} = \frac{W}{It}$$

2. i (a) Doubled

Explanation:

$$E \propto t$$

ii. (c) 3600J

Explanation:

Given: $P = 60\text{W}, t = 1\text{ min}$

$$E = 60 \times 1 \times 60 = 3600\text{J}$$

iii. (b) ₹ 16

Explanation:

Given: $P = 400\text{W}, t = 8\text{ hour}$

$$E = 400 \times 8 = 3200\text{Wh} = 3.2\text{kWh.}$$

$$\text{Cost} = 3.2 \times 5 = ₹ 16$$

iv. (a) 90kJ

Explanation:

Given: $I = 5\text{A},$

$$R = 2\Omega, t = 30\text{ min}$$

$$E = I^2Rt = 5 \times 5 \times 2 \times 30 \times 60$$

$$E = 90000\text{J} = 90\text{kJ}$$

v. (a) 1 watt hour = 3600J

Explanation:

1 watt hr = 3600J.

