

SCIENCE

(Physics)

Chapter 10: Light – Reflection and Refraction

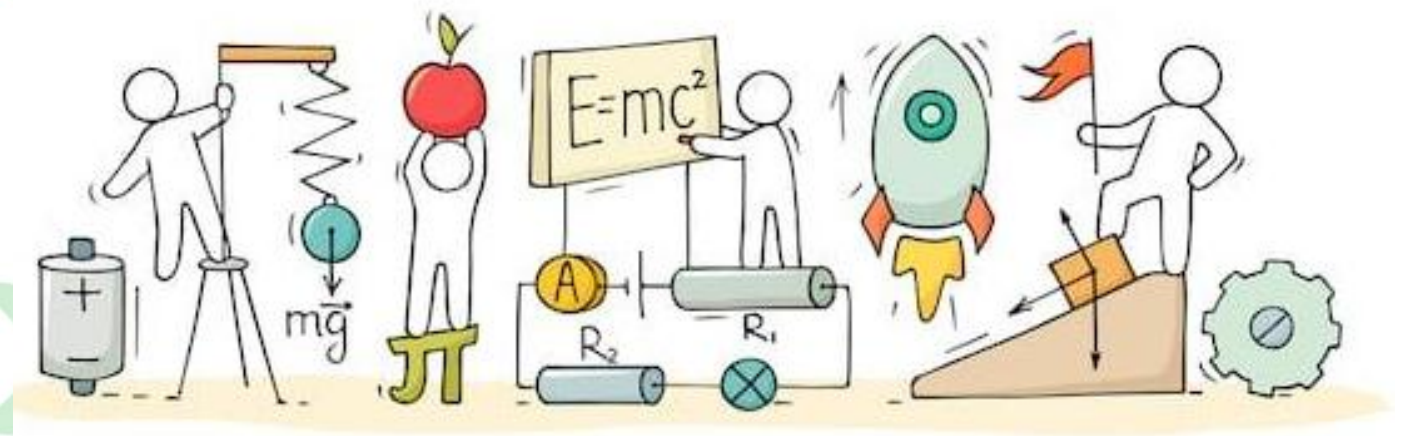

Light – Reflection and Refraction

Reflection of Light

- Reflection is the phenomenon of bouncing back of light into the same medium on striking the surface of any object.
- **Laws of Reflection**
 - **First law:** The incident ray, the normal to the surface at the point of incidence and the reflected ray, all lie in the same plane.
 - **Second law:** The angle of reflection (r) is always equal to the angle of incidence (i).
 $\angle i = \angle r$
- The image formed by a **plane mirror** is always
 - virtual and erect
 - of the same size as the object
 - as far behind the mirror as the object is in front of it
 - laterally inverted

Spherical mirrors are of two types:

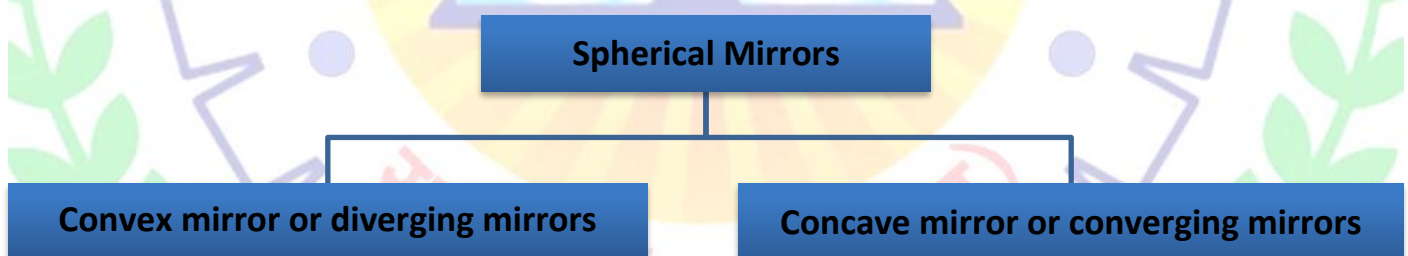

- **Convex mirrors or diverging mirrors** in which the reflecting surface is curved outwards.
- **Concave mirrors or converging mirrors** in which the reflecting surface is curved inwards.

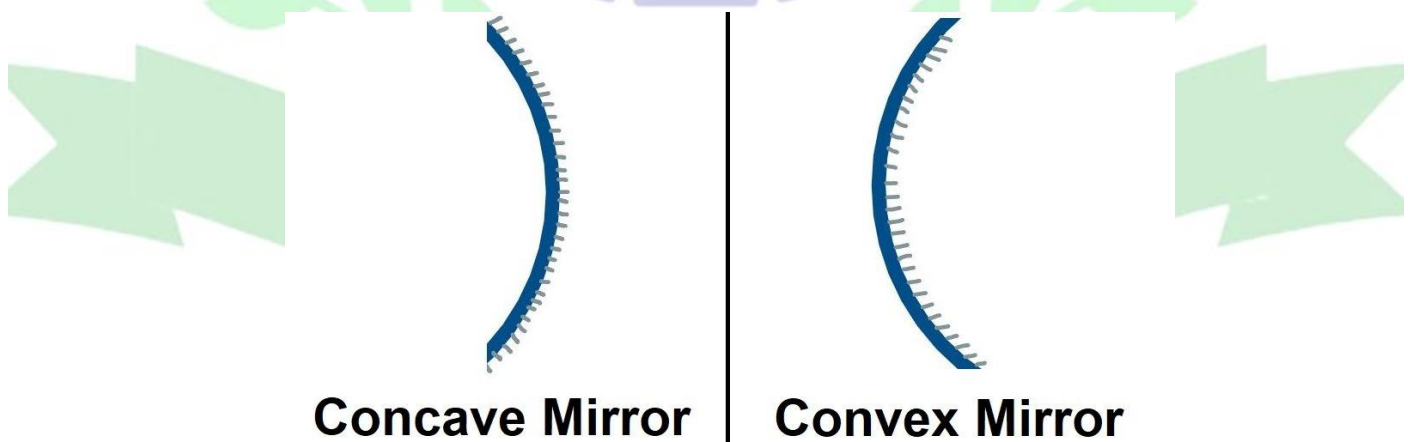

Some terms related to spherical mirrors:

- The **centre of curvature (C)** of a spherical mirror is the centre of the hollow sphere of glass, of which the spherical mirror is apart.

- The **radius of curvature (R)** of a spherical mirror is the radius of the hollow sphere of glass, of which the spherical mirror is a part.
- The **pole (P)** of a spherical mirror is the centre of the mirror.
- The **principal axis** of a spherical mirror is a straight line passing through the centre of curvature C and pole P of the spherical mirror.
- The **principal focus (F) of a concave mirror** is a point on the principal axis at which the rays of light incident on the mirror, in a direction parallel to the principal axis, actually meet after reflection from the mirror.
- The **principal focus (F) of a convex mirror** is a point on the principal axis from which the rays of light incident on the mirror, in a direction parallel to the principal axis, appear to diverge after reflection from the mirror.
- The **focal length (f)** of a mirror is the distance between its pole (P) and principal focus (F).
- For spherical mirrors of small aperture, $R = 2f$.

Sign Conventions for Spherical Mirrors

According to **New Cartesian Sign Conventions**,

- All distances are measured from the pole of the mirror.
- The distances measured in the direction of incidence of light are taken as positive and *viceversa*.
- The heights above the principal axis are taken as positive and *viceversa*.

Rules for tracing images formed by Spherical Mirrors

Rule 1: A ray which is parallel to the principal axis after reflection passes through the principal focus in case of a concave mirror or appears to diverge from the principal focus in case of a convex mirror.

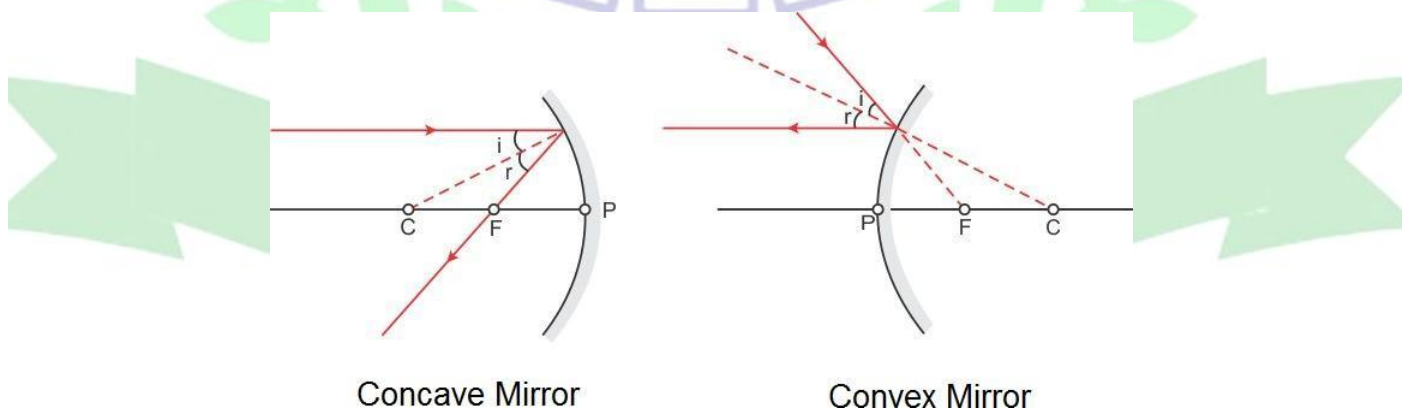

Rule 2: A ray passing through the principal focus of a concave mirror or a ray which is directed towards the principal focus of a convex mirror emerges parallel to the principal axis after reflection.

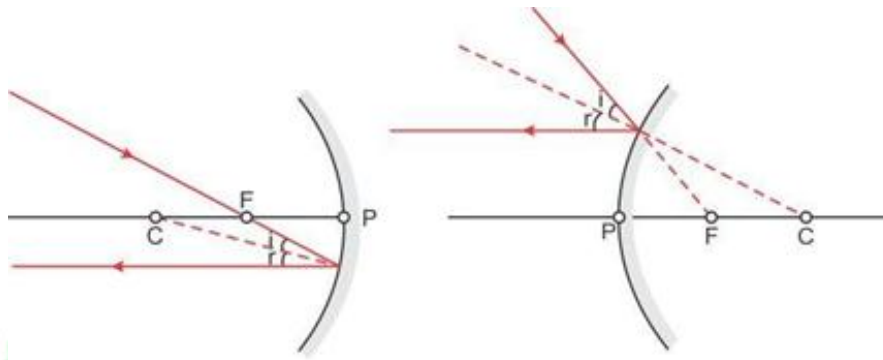

Concave Mirror

Convex Mirror

Rule 3: A ray passing through the centre of curvature of a concave mirror or directed towards the centre of curvature of a convex mirror is reflected back along the same path.

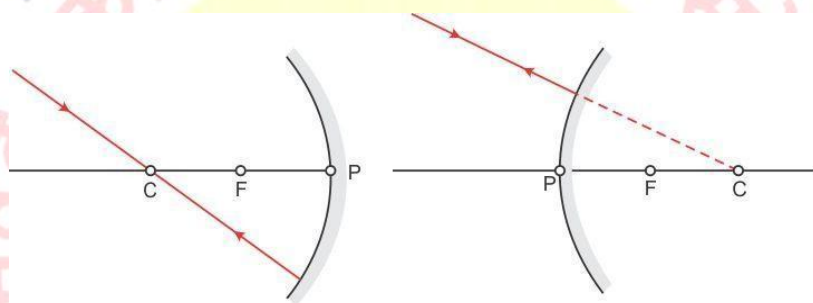

Concave Mirror

Convex Mirror

Rule 4: A ray incident obliquely towards the pole of a concave mirror or a convex mirror is reflected obliquely as per the laws of reflection.

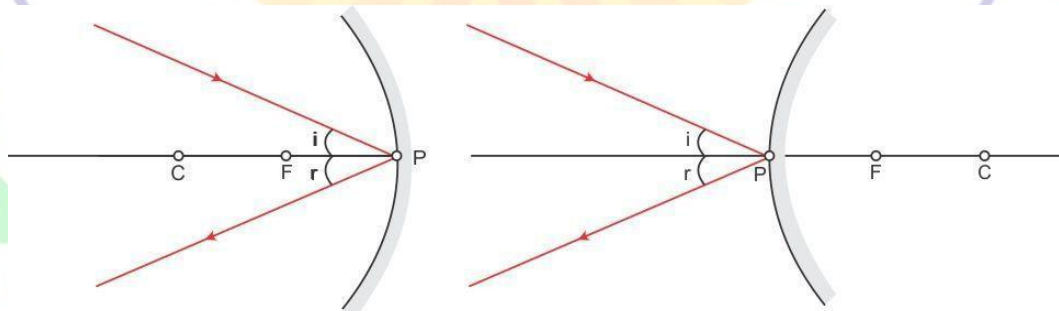
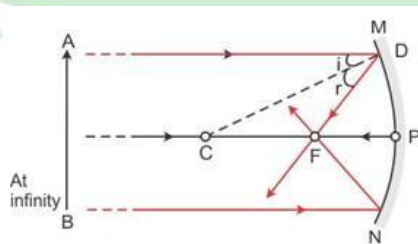
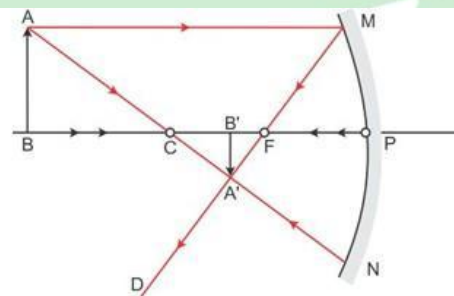

Image formation by a concave mirror

• Ray Diagrams



Object at infinity

Object beyond C

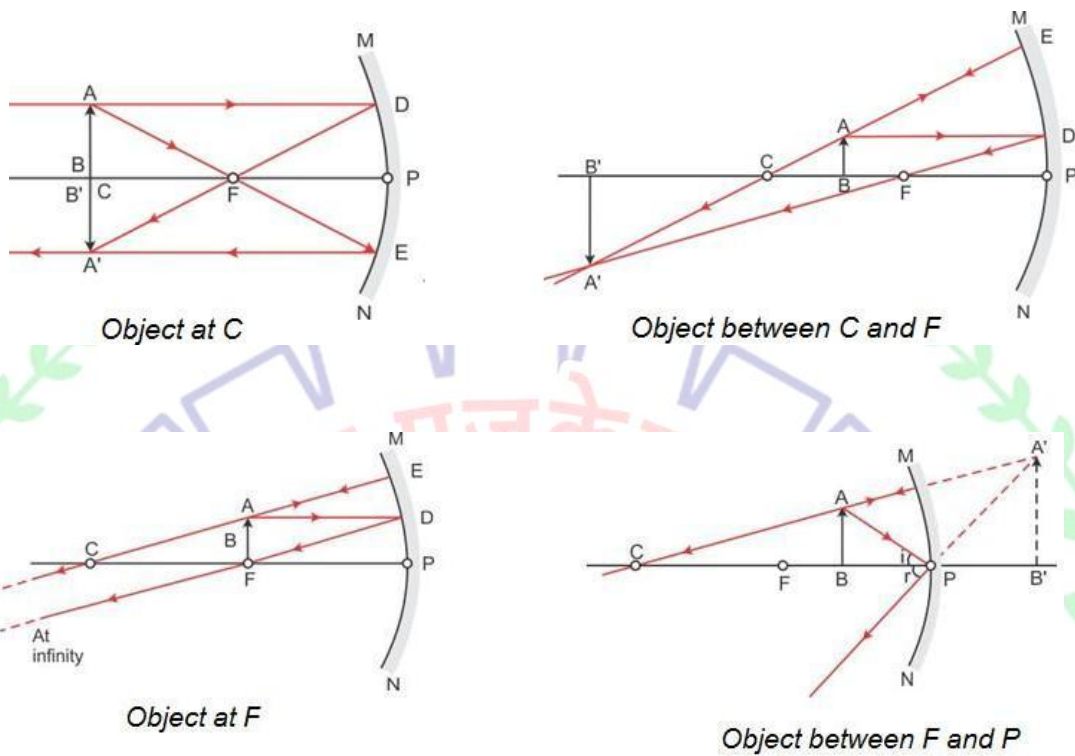

• Characteristics of images formed

Position of object	Position of image	Size of image	Nature of image
At infinity	At focus F	Highly diminished	Real and inverted
Beyond C	Between F and C	Diminished	Real and inverted
At C	At C	Equal to size of object	Real and inverted
Between C and F	Beyond C	Enlarged	Real and inverted
At F	At infinity	Highly enlarged	Real and inverted
Between F and P	Behind the mirror	Enlarged	Virtual and erect

Image formation by a convex mirror

• Ray Diagrams

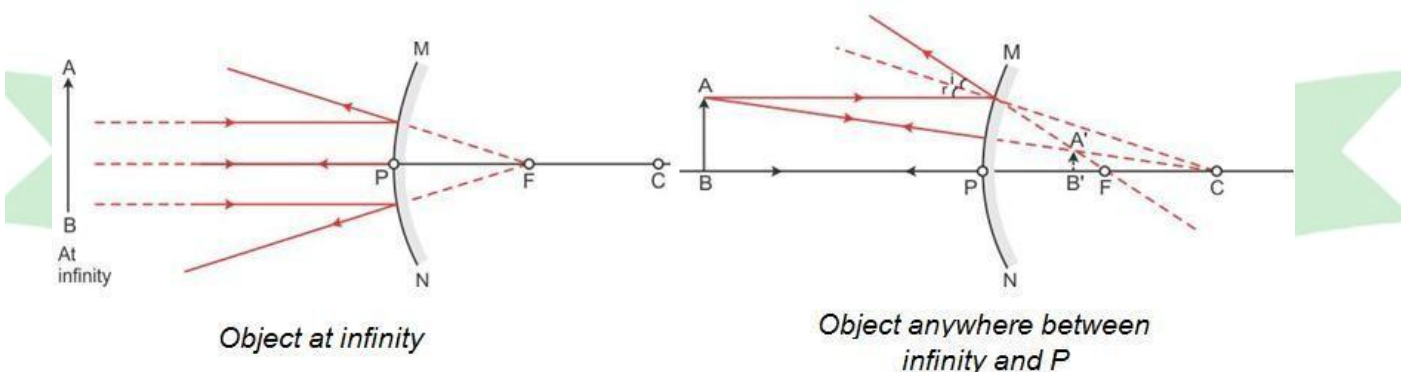

• Characteristics of images formed

Position of object	Position of image	Size of image	Nature of image
At infinity	At focus F behind the mirror	Highly diminished, point sized	Virtual and erect

Anywhere between infinity and the pole of the mirror	Between P and F behind the mirror	Diminished	Virtual and erect
--	-----------------------------------	------------	-------------------

Sign Convention for Reflection by Spherical Mirrors

While dealing with the reflection of light by spherical mirrors, we shall follow a set of sign conventions called the New Cartesian Sign Convention. In this convention, the pole (P) of the mirror is taken as the origin. The principal axis of the mirror is taken as the x-axis (X'X) of the coordinate system. The conventions are as follows:

- The object is always placed to the left of the mirror. This implies that the light from the object falls on the mirror from the left-hand side.
- All distances parallel to the principal axis are measured from the pole of the mirror.
- All the distances measured to the right of the origin (along + x-axis) are taken as positive while those measured to the left of the origin (along – x-axis) are taken as negative.
- Distances measured perpendicular to and above the principal axis (along + y-axis) are taken as positive.
- Distances measured perpendicular to and below the principal axis (along –y-axis) are taken as negative.

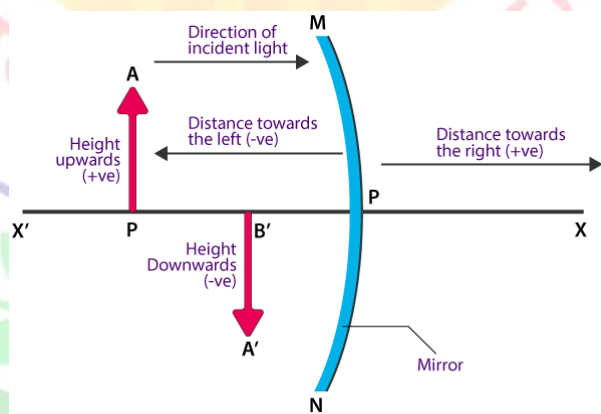

The New Cartesian Sign Convention for spherical mirrors

• Mirror Formula

The object distance (u), image distance (v) and focal length (f) of a spherical mirror are related as

$$\frac{1}{f} = \frac{1}{u} + \frac{1}{v}$$

• Linear Magnification (m)

The magnification produced by a spherical mirror indicates the extent to which an object's image is magnified in relation to the object size.

Magnification is defined as the ratio of the image's height to the object's height. The letter m is commonly used to represent it.

If h is the object's height and h' is the image's height, then the magnification m produced by a spherical mirror can be written as

$$m = \frac{\text{Height of the Image}}{\text{Height of the object}} = \frac{h'}{h}$$

m is **negative** for real images and **positive** for virtual images.

Refraction of Light

- The phenomenon of change in the path of a beam of light as it passes from one medium to another is called refraction of light.
- The **cause of refraction** is the change in the speed of light as it goes from one medium to another.
- **Laws of Refraction**
 - **First Law:** The incident ray, the refracted ray and the normal to the interface of two media at the point of incidence, all lie in the same plane.
 - **Second Law:** The ratio of the sine of the angle of incidence to the sine of the angle of refraction is constant for a given pair of media.

$$\frac{\sin i}{\sin r} = \text{constant} = {}^1n_2$$

This law is also known as **Snell's law**.

The constant, written as 1n_2 is called the **refractive index** of the second medium (in which the refracted ray lies) with respect to the first medium (in which the incident ray lies).

- **Absolute refractive index (n)** of a medium is given as

$$n = \frac{\text{speed of light in vacuum}}{\text{speed of light in the medium}} = \frac{c}{v}$$

- When a beam of light passes from medium 1 to medium 2, the refractive index of medium 2 with respect to medium 1 is called the **relative refractive index**, represented by 1n_2 , where

$${}^1n_2 = \frac{n_2}{n_1} = \frac{c/v_2}{c/v_1} = \frac{v_1}{v_2}$$

Similarly, the refractive index of medium 1 with respect to medium 2 is

$${}^2n_1 = \frac{n_1}{n_2} = \frac{c/v_1}{c/v_2} = \frac{v_2}{v_1}$$

$$\Rightarrow {}^1n_2 \times {}^2n_1 = 1$$

$$\text{or, } {}^1n_2 = \frac{1}{{}^2n_1}$$

- While going from a **rarer to a denser medium**, the ray of **light bends towards the normal**. While going from a **denser to a rarer medium**, the ray of **light bends away from the normal**.
- **Conditions for no refraction**
 - When light is incident normally on a boundary.
 - When the refractive indices of the two media are equal.
- In the case of a **rectangular glass slab**, a ray of light suffers **two refractions**, one at the air–glass interface and the other at the glass–air interface. The emergent ray is **parallel** to the direction of the incident ray.

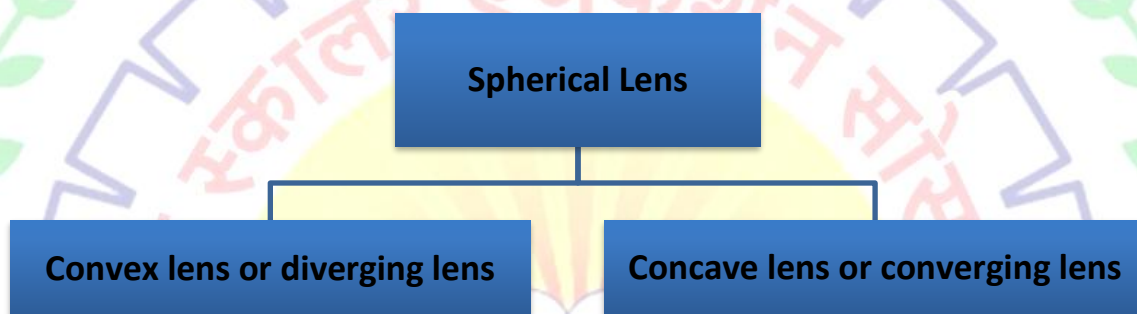

- **Convex lens or converging lens** which is thick at the centre and thin at the edges.
- **Concave lens or diverging lens** which is thin at the centre and thick at the edges.
- Some terms related to spherical lenses:
 - The central point of the lens is known as its **optical centre(O)**.
 - Each of the two spherical surfaces of a lens forms a part of a sphere. The centres of these spheres are called **centres of curvature** of the lens. These are represented as **C₁** and **C₂**.
 - The **principal axis** of a lens is a straight line passing through its two centres of curvature.
 - The **principal focus of a convex lens** is a point on its principal axis to which light rays parallel to the principal axis converge after passing through the lens.
 - The **principal focus of a concave lens** is a point on its principal axis from which light rays, originally parallel to the principal axis appear to diverge after passing through the lens.
 - The **focal length (f)** of a lens is the distance of the principal focus from the optical centre.
- **Sign Conventions for Spherical Lenses**
According to **New Cartesian Sign Conventions**,
 - All distances are measured from the optical centre of the lens.
 - The distances measured in the direction of incidence of light are taken as positive and *viceversa*.
 - The heights above the principal axis are taken as positive and *viceversa*.
- **Rules for tracing images formed by spherical lens**
Rule 1: A ray which is parallel to the principal axis, after refraction passes through the

principal focus on the other side of the lens in case of a convex lens or appears to diverge from the principal focus on the same side of the lens in case of a concave lens.

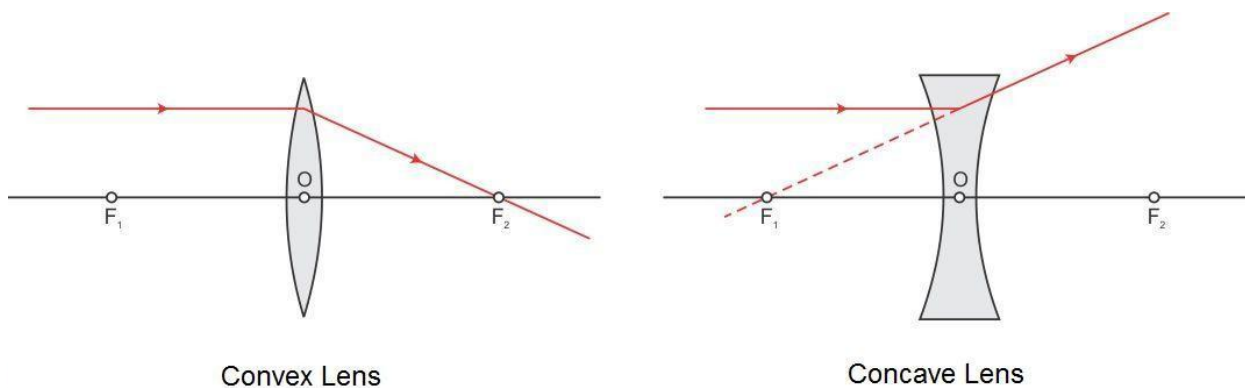

Rule 2: A ray passing through the principal focus of a convex lens or appearing to meet at the principal focus of a concave lens after refraction emerges parallel to the principal axis.

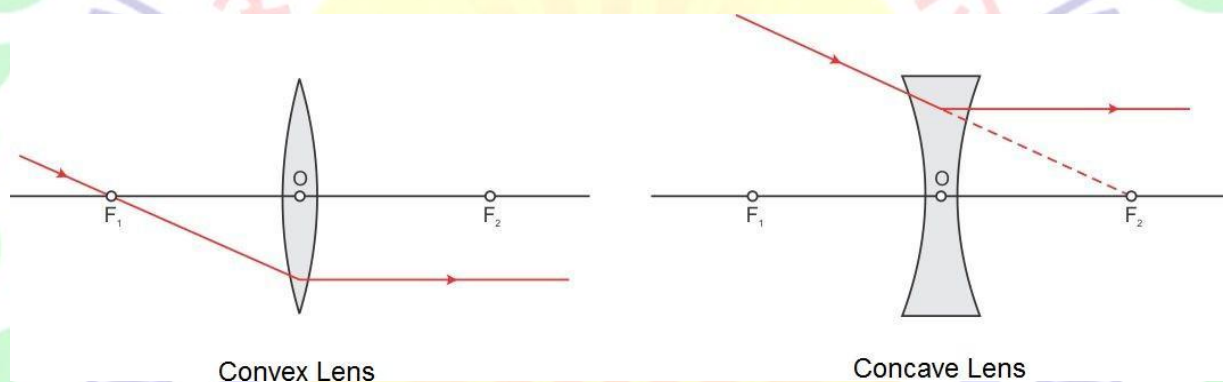

Rule 3: A ray passing through the optical centre of a convex lens or a concave lens emerges without any deviation.

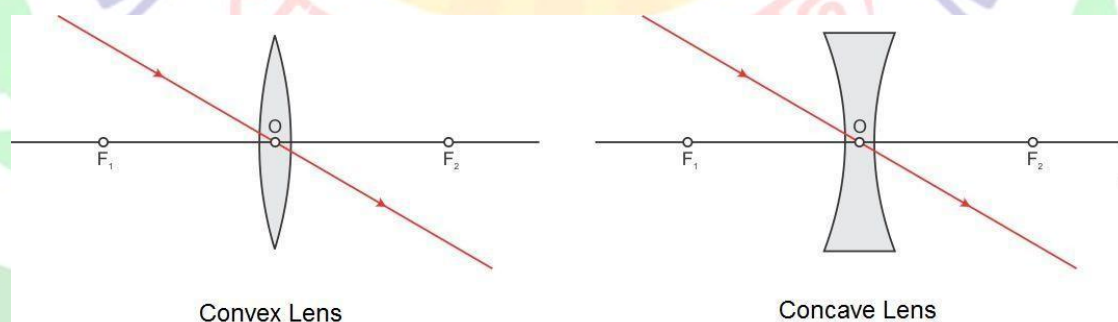
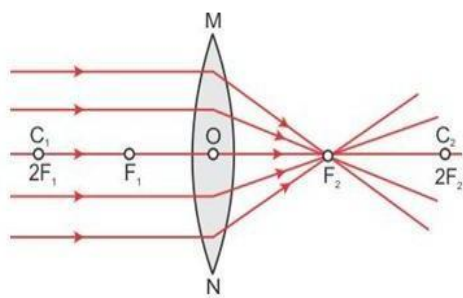
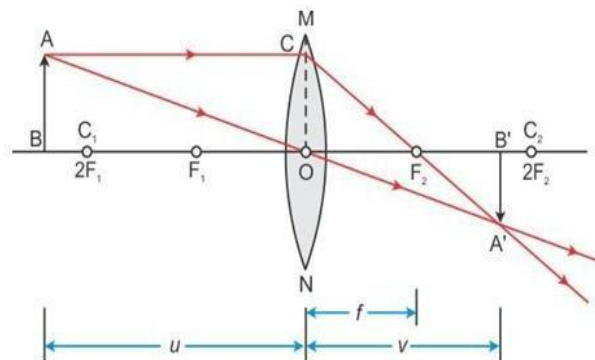
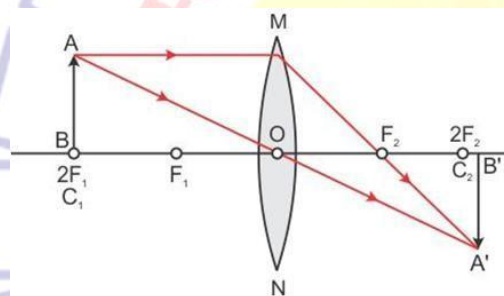
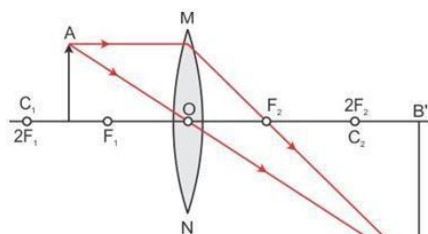
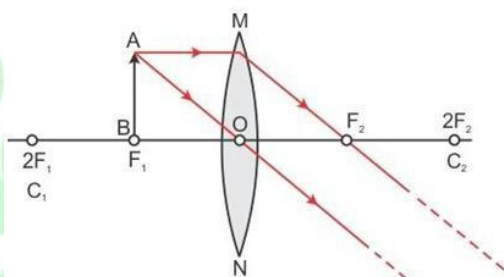
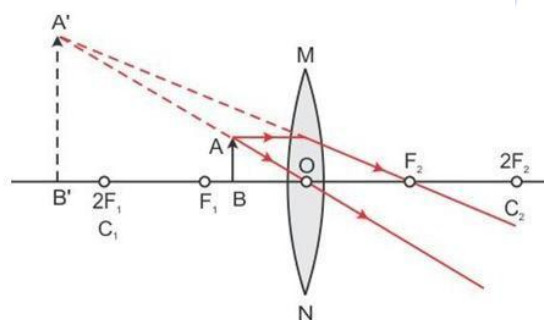

Image formation by a convex lens

- Ray Diagrams



Object at infinity

Object beyond $2F_1$ Object at $2F_1$ Object between F_1 and $2F_1$ Object at F_1 Object between F_1 and O

- Characteristics of images formed

Position of object	Position of image	Size of image	Nature of image
At infinity	At focus F_2	Highly diminished	Real and inverted
Beyond $2F_1$	Between F_2 and $2F_2$	Diminished	Real and inverted
At $2F_1$	At $2F_2$	Equal to size of object	Real and inverted
Between F_1 and $2F_1$	Beyond $2F_2$	Enlarged	Real and inverted
At focus F_1	At infinity	Highly enlarged	Real and inverted
Between F_1 and O	Beyond F_1 on the same side as the object	Enlarged	Virtual and erect

- Image formation by a concave lens

○ Ray Diagrams

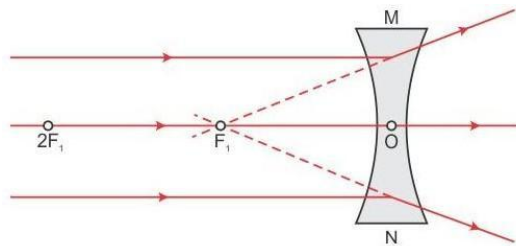

Object at infinity

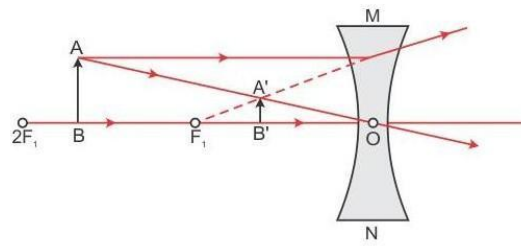

Object between infinity and optical centre

○ Characteristics of images formed

Position of object	Position of image	Size of image	Nature of image
At infinity	At focus F_1	Highly diminished	Virtual and erect
Between infinity and O	Between focus F_1 and O	Diminished	Virtual and erect

● Lens Formula

Object distance (u), image distance (v) and focal length (f) of a spherical lens are related as

$$\frac{1}{v} - \frac{1}{u} = \frac{1}{f}$$

- **Linear Magnification (m)** produced by a spherical lens is

$$m = \frac{\text{Height of the Image}}{\text{Height of the object}} = \frac{h'}{h}$$

m is **negative** for real images and **positive** for virtual images.

● Power of a lens

- Power of a lens is the reciprocal of the focal length of the lens. Its S.I. unit is **diopetre (D)**.

$$P \text{ (diopetre)} = \frac{1}{f \text{ (metre)}}$$

- Power of a **convex lens** is **positive** and that of a **concave lens** is **negative**.
- When several thin lenses are placed in contact with one another, the **power of the combination of lenses** is equal to the algebraic sum of the powers of the individual lenses.

$$P = P_1 + P_2 + P_3 + P_4 + \dots$$

Class : 10th Physics
Chapter-10 : Light—Reflection and Refraction

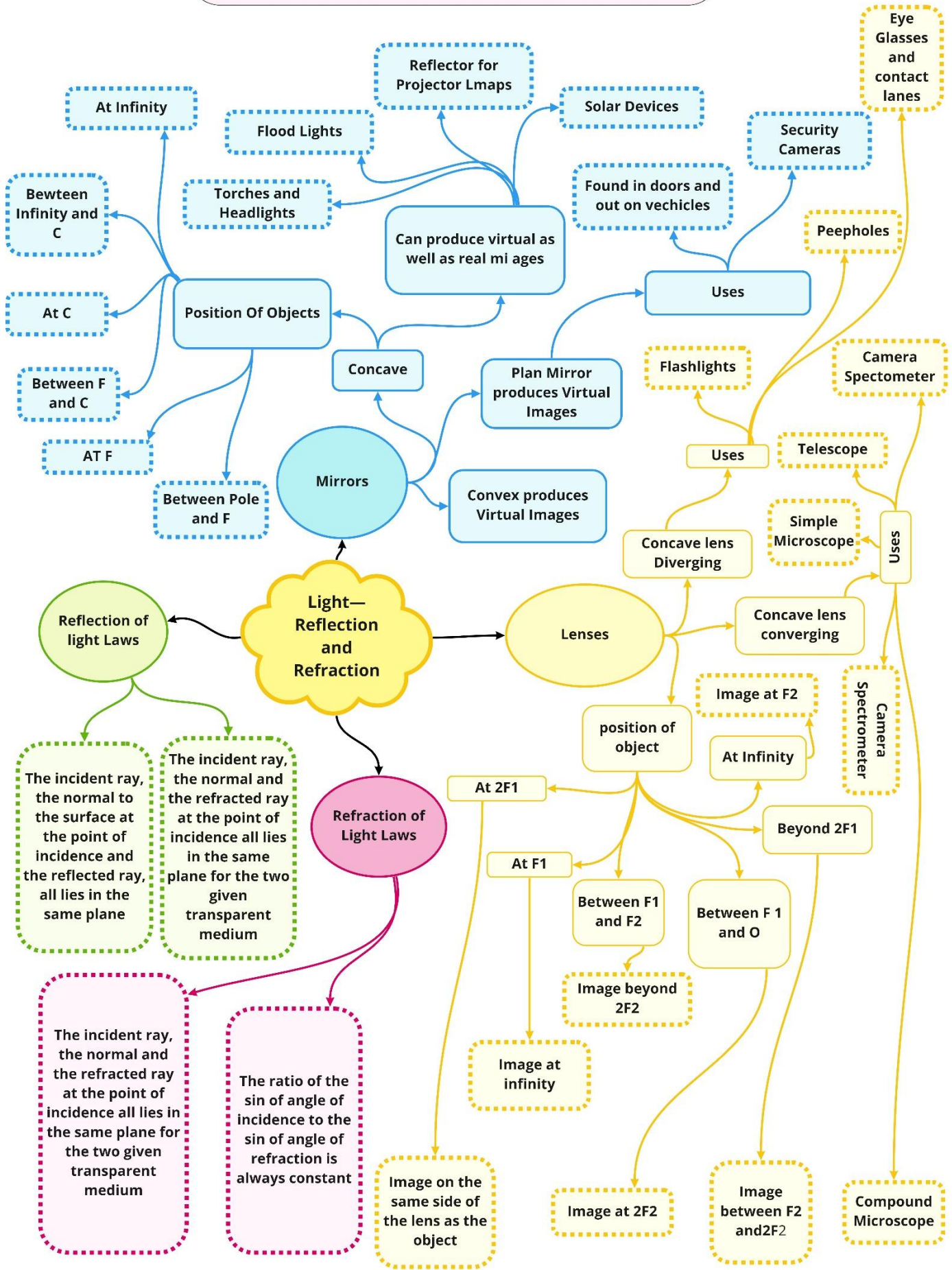

Important Questions

Multiple Choice Questions:

1. Which of the following can make a parallel beam of light when light from a point source is incident on it?

- (a) Concave mirror as well as convex lens
- (b) Convex mirror as well as concave lens
- (c) Two plane mirrors placed at 90° to each other
- (d) Concave mirror as well as concave lens

2. A 10 mm long awl pin is placed vertically in front of a concave mirror. A 5 mm long image of the awl pin is formed at 30 cm in front of the mirror. The focal length of this mirror is

- (a) -30 cm
- (b) -20 cm
- (c) -40 cm
- (d) -60 cm

3. Under which of the following conditions a concave mirror can form an image larger than the actual object?

- (a) When the object is kept at a distance equal to its radius of curvature
- (b) When object is kept at a distance less than its focal length
- (c) When object is placed between the focus and center of curvature
- (d) When object is kept at a distance greater than its radius of curvature

4. The diagrams showing the correct path of the ray after passing through the

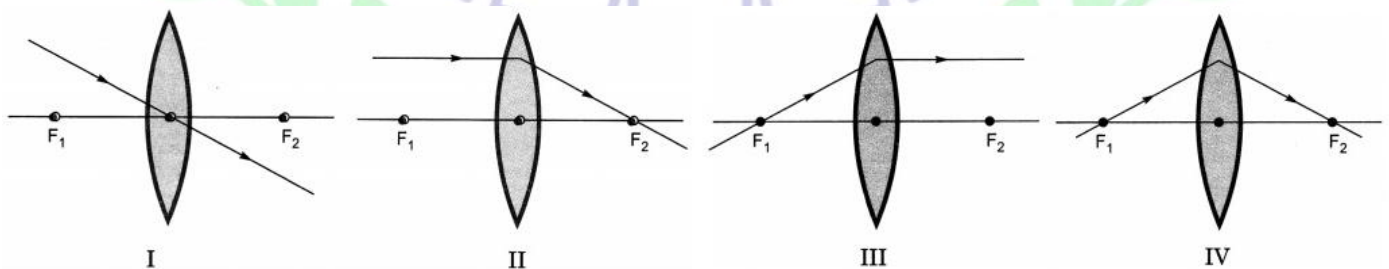

- (a) II and III only
- (b) I and II only
- (c) I, II and III
- (d) I, II and IV

5. A light ray enters from medium A to medium B as shown in figure. The refractive

index of medium B relative to A will be

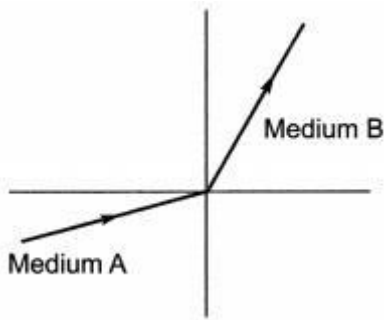

- (a) greater than unity
- (b) less than unity
- (c) equal to unity
- (d) zero

6. Beams of light are incident through the holes A and B and emerge out of box through the holes C and D respectively as shown in the figure. Which of the following could be inside the box?

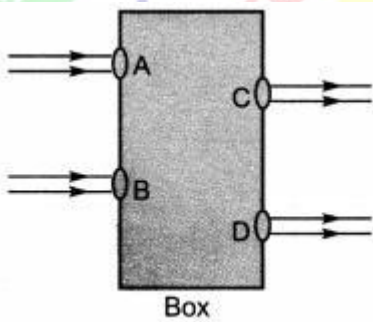

- a) A rectangular glass slab
- (b) A convex lens
- (c) A concave lens
- (d) A prism

7. A beam of light is incident through the holes on side A and emerges out of the holes on the other face of the box as show in the figure. Which of the following could be inside the box?

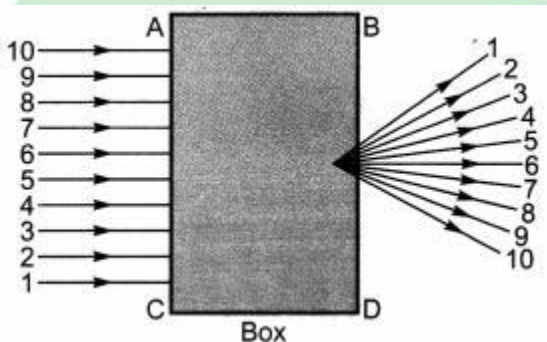

- (a) Concave lens
- (b) Rectangular glass slab

(c) Prism

(d) Convex lens

8. Which of the following statements is true?

(a) A convex lens has 4 dioptre power having a focal length 0.25 m

(b) A convex lens has -4 dioptre power having a focal length 0.25 m

(c) A concave lens has 4 dioptre power having a focal length 0.25 m

(d) A concave lens has -4 dioptre power having a focal length 0.25 m.

9. Magnification produced by a rear view mirror fitted in vehicles

(a) is less than one

(b) is more than one

(c) is equal to one

(d) can be more than or less than one depending upon the position of the object in front of it.

10. Rays from Sun converge at a point 15 cm in front of a concave mirror. Where should an object be placed so that size of its image is equal to the size of the object?

(a) 15 cm in front of the mirror

(b) 30 cm in front of the mirror

(c) between 15 cm and 30 cm in front of the mirror

(d) more than 30 cm in front of the mirror

Very Short Question:

1. Define reflection of light?

2. What is a reflector?

3. State laws of reflection.

4. What are the values of angle of incidence $\angle i$ and angle of reflection $\angle r$ for normal incidence of light on a plane mirror?

5. What is real image?

6. What is virtual image?

7. Mention the nature of image produced by a plane mirror.

8. Define center of curvature of a spherical mirror.

9. Define radius of curvature of a spherical mirror.

10. Define aperture of a spherical mirror.

Short Questions:

1. List two differences between real and virtual images.

2. State the laws of reflection of light.
3. With the ray diagram show that angle of incidence is equal to the angle of reflection when a ray is incident on the concave mirror.
4. An object is placed at the following distances from a concave mirror of focal length 15 cm.
 - (a) 10 cm
 - (b) 20 cm
 - (c) 30 cm
 - (d) 40 cm

Which position of the object will produce

- Virtual image
 - A diminished real image
 - An enlarged real image
 - An image of same size.
5. Draw ray diagram to show the formation of images when the object is placed in front of a concave mirror
 - (i) between its pole and focus point,
 6. State three uses of a concave mirror.
 7. State two uses of a convex mirror.
 8. Parallel rays of light incident on a concave mirror and a convex mirror as shown in figure,
 - (i) Redraw the reflected rays in both the cases,
 - (ii) Name the points where the reflected rays meet or appear to meet on the principal axis.

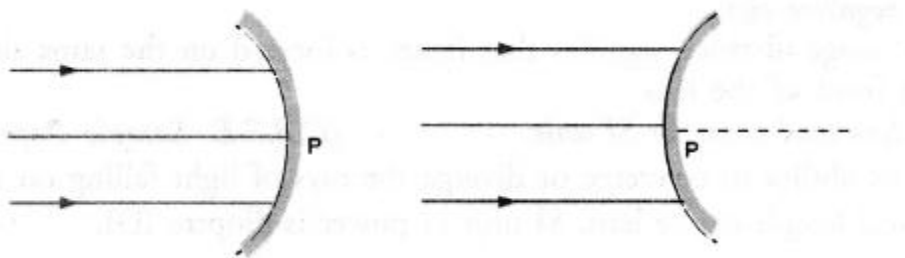

? Long Questions:

1. A thin converging lens forms a:
 - (i) real magnified image
 - (ii) virtual magnified image of an object placed in front of it.
- (a) Write the positions of the objects in each case.

(b) Draw labelled diagrams to show the image formation in each case.

(c) How will the following be affected on cutting this lens into two halves along the principal axis?

- focal length,
- intensity of the image formed by half lens.

2. For the given data showing object distance and focal length of three concave mirrors, answer the following questions:

S.No.	Object distance (cm)	Focal length (cm)
1.	30	20
2.	10	15
3.	20	10

- Out of the three in which case the mirror will form the image having same size as the object?
- Which mirror is being used as a make-up-mirror?
- Draw the ray diagram for part (1) and part (2)

? Assertion Reason Questions:

1. For two statements are given-one labelled Assertion (A) and the other labelled Reason (R). Select the correct answer to these questions from the codes (a), (b), (c) and (d) as given below:
- Both A and R are true, and R is correct explanation of the assertion.
 - Both A and R are true, but R is not the correct explanation of the assertion.
 - A is true, but R is false.
 - A is false, but R is true.

Assertion: Keeping a point object fixed, if a plane mirror is moved, the image will also move.

Reason: In case of a plane mirror, distance of object and its image is equal from any point on the mirror.

2. For two statements are given-one labelled Assertion (A) and the other labelled Reason (R). Select the correct answer to these questions from the codes (a), (b), (c) and (d) as given below:
- Both A and R are true, and R is correct explanation of the assertion.
 - Both A and R are true, but R is not the correct explanation of the assertion.
 - A is true, but R is false.
 - A is false, but R is true.

Assertion: The size of the mirror affects the nature of the image.

Reason: Small mirrors always form virtual images.

Case Study Questions:

1. Read the following and answer any four questions from (i) to (v).

When the rays of light travels from one transparent medium to another, the path of light is deviated. This phenomenon is called refraction of light. The bending of light depends on the optical density of medium through which the light pass.

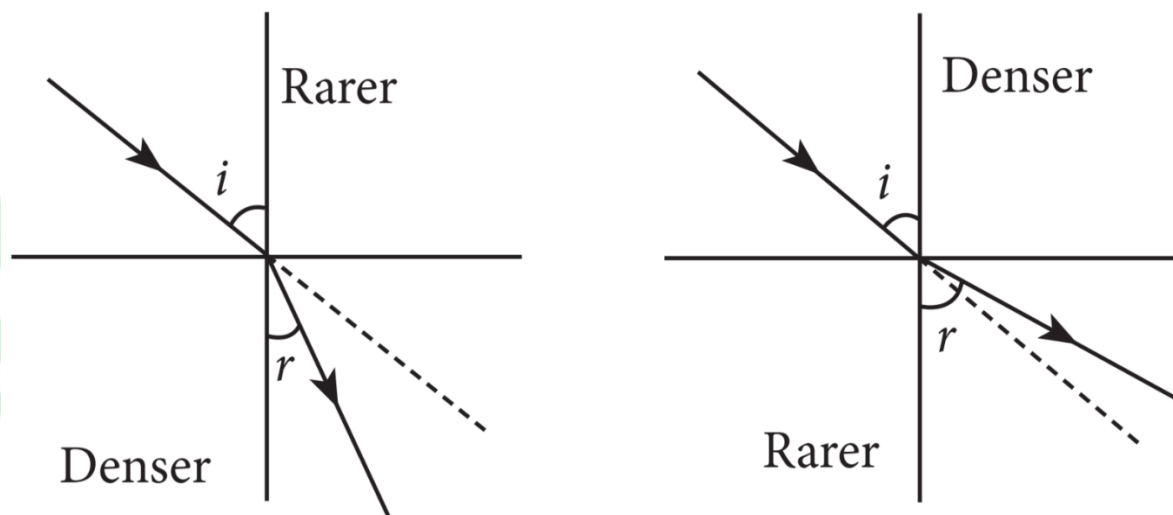

This speed of light varies from medium to medium. A medium in which the speed of light is more is optically rarer medium whereas in which the speed of light is less is optically denser medium. Whenever light goes from one medium to another, the frequency of light does not change however, speed and wavelength change. It concluded that change in speed of light is the basic cause of refraction.

- i. When light travels from air to glass, the ray of light bends:
 - a. Towards the normal.
 - b. Away from normal.
 - c. Anywhere.
 - d. None of these.
- ii. A ray of light passes from a medium A to another medium B. No bending of light occurs if the ray of light hits the boundary of medium B at an angle of:
 - a. 0°
 - b. 45°
 - c. 90°
 - d. 120°
- iii. When light passes from one medium to another, the frequency of light:
 - a. Increases
 - b. Decreases
 - c. Remains same

- d. None of these
- iv. When light passes from glass to water, the speed of light:
- Increases.
 - Decreases.
 - Remains same.
 - First increases then decrease.
- v. The bottom of pool filled with water appears to be due to refraction of light:
- Shallower
 - Deeper
 - At same depth
 - Empty
2. The lenses form different types of images when object placed at different locations. When a ray is incident parallel to the principal axis, then after refraction, it passes through the focus or appears to come from the focus. When a ray goes through the optical centre of the lens, it passes without any deviation. If the object is placed between focus and optical center of the convex lens, erect and magnified image is formed. As the object is brought closer to the convex lens from infinity to focus, the image moves away from the convex lens from focus to infinity. Also, the size of image goes on increasing and the image is always real and inverted. A concave lens always gives a virtual, erect, and diminished image irrespective to the position of the object.
- i. The location of image formed by a convex lens when the object is placed at infinity is
- At focus
 - At $2F$
 - At optical center
 - Between F and $2F$
- ii. When the object is placed at the focus of concave lens, the image formed is:
- Real and smaller
 - Virtual and inverted
 - Virtual and smaller
 - Real and erect
- iii. The size of image formed by a convex lens when the object is placed at the focus of convex lens is:
- Small
 - Point in size

- c. Highly magnified
d. Same as that of object
- iv. When the object is placed at $2F$ in front of convex lens, the location of image is:
a. At F
b. At $2F$ on the other side
c. At infinity
d. Between F and optical center
- v. At which location of object in front of concave lens, the image between focus and optical centre is formed:
a. Anywhere between centre and infinity
b. At F
c. At $2F$
d. Infinity

✓ Answer Key-

❓ Multiple Choice Answers:

1. (a) Concave mirror as well as convex lens
2. (b) -20 cm
3. (c) When object is placed between the focus and centre of curvature
4. (c) I, II and III
5. (a) greater than unity
6. (a) A rectangular glass slab
7. (d) Convex lens
8. (a) A convex lens has 4 dioptre power having a focal length 0.25 m
9. (a) is less than one
10. (b) 30 cm in front of the mirror

❓ Very Short Answers:

1. Answer: The process of returning or bouncing back the light to the same medium after striking the surface is called reflection of light.
2. Answer: A surface which reflects the light is called reflector.
3. Answer: Angle of incidence is equal to the angle of reflection. That is, $\angle i = \angle r$.
Incident ray, reflected ray and normal to the reflecting surface at the point of incidence lie in the same plane.

4. Answer: For normal incidence, $\angle i = 0$. Therefore, according to law of reflection $\angle r = \angle i = 0$.
5. Answer: When rays of light from an object actually meet at a point after refraction, then image formed is real.
6. Answer: When rays of light from an object do not meet at a point but appears to meet at a point, then image formed is virtual.
7. Answer: Image is virtual, erect and of the same size as that of the object.
8. Answer: The center of a hollow sphere of which the spherical mirror forms a part is called the center of curvature of the spherical mirror.
9. Answer: The radius of a hollow sphere of which the spherical mirror forms a part is called radius of curvature of the spherical mirror.
10. Answer: The part of spherical mirror exposed to the incident light is called the aperture of the spherical mirror.

? Short Answers:

1. Answer:

Real Image	Virtual Image
Real images are formed by a concave mirror	Convex mirror form a virtual image
Real images are formed due to the actual intersection of light rays	Virtual images are formed due to the imaginary intersection of light rays

2. Answer:

Angle of incidence is equal to the angle of reflection. That is, $\angle i = \angle r$.

Incident ray, reflected ray and normal to the reflecting surface at the point of incidence lie in the same plane.

3. Answer:

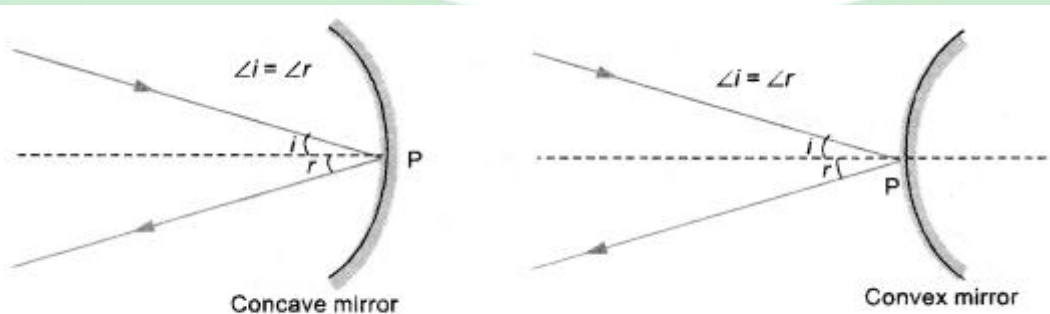

FIGURE 17

4. Answer:

Concave mirror forms virtual image if object is placed between the focus and pole of the mirror. Therefore, for the position of object at 10 cm mirror forms the required image.

A real and diminished image is formed when object lies beyond C i.e., beyond $2F$. So, for the position of object at 40 cm, mirror forms the required image.

An enlarged real image is formed when object lies between F and $2F$. So, for the position of object at 20 cm, mirror forms the required image.

An image of same size of the object is formed when object lies at C or $2F$. So, for the position of object at 30 cm, mirror forms the required image.

5. Answer:

(i)

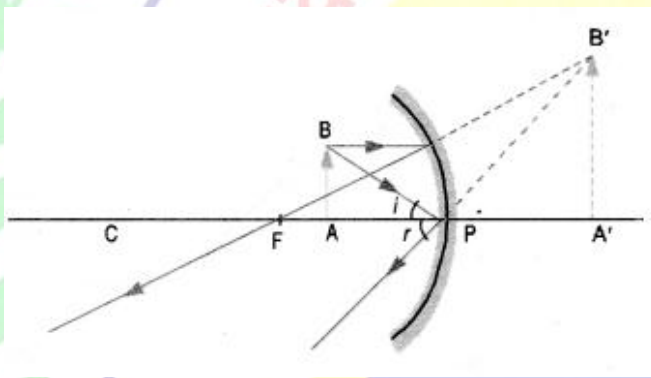

(ii)

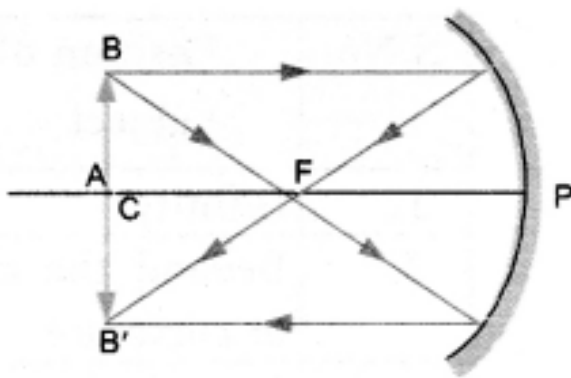

6. Answer:

Reflector: Concave mirrors are used in motor head lights, search lights and torches etc. to produce an intense parallel beam of light. A bulb is placed at the focus of concave mirror or concave reflecting surface. The beam of light from the bulb after reflecting from the concave mirror goes as a parallel beam (figure 24).

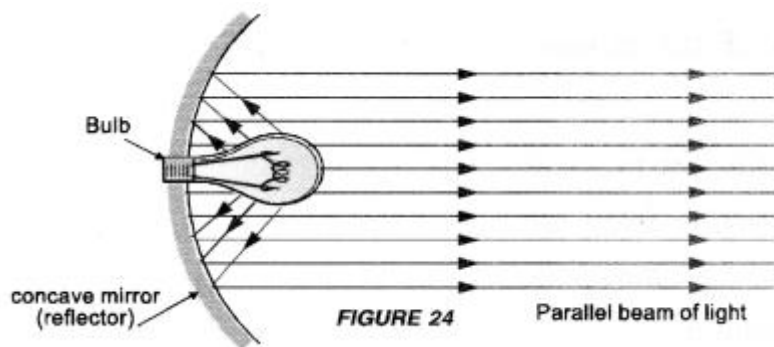

This parallel beam of – light illuminates the road ahead of the vehicle.

Shaving and make up mirror: When an object is placed close to a concave mirror (i.e between the pole and focus of the concave mirror), an erect and enlarged (large in

size) image of the object is formed. Because of this fact, concave mirror is used by men to see their enlarged faces while shaving. Similarly, a lady can see her face better with the help of a concave mirror while doing make up.

In solar cookers: When a parallel beam of sun light falls on a concave mirror, this beam is brought to the focus of the concave mirror. As a result of this, the temperature of an object (say a container containing un-cooked food) placed at this focus increases considerably. Hence the food in the container is cooked (figure 25).

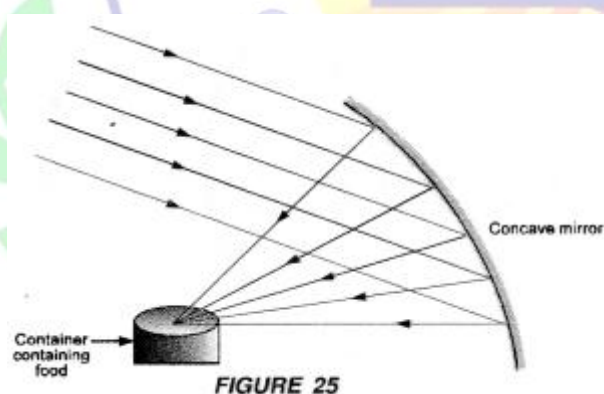

7. Answer:

Rear view or driver's mirror. Convex mirror is used as a rear view mirror in vehicles because this mirror forms an erect and diminished image of an object behind the vehicle. Since the image of the object formed is small in size, so the field of view is increased. It means, the driver of a vehicle can see the traffic over large area behind his vehicle. This mirror is also known as driver's mirror.

In street lights. Convex mirror is used in street lights to diverge light over a large area (figure 28).

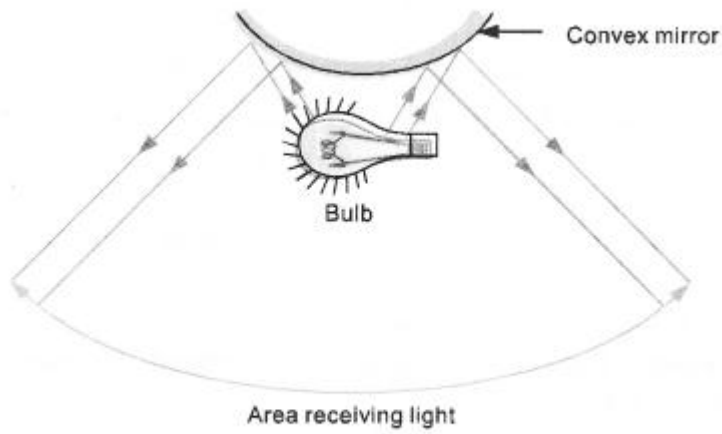
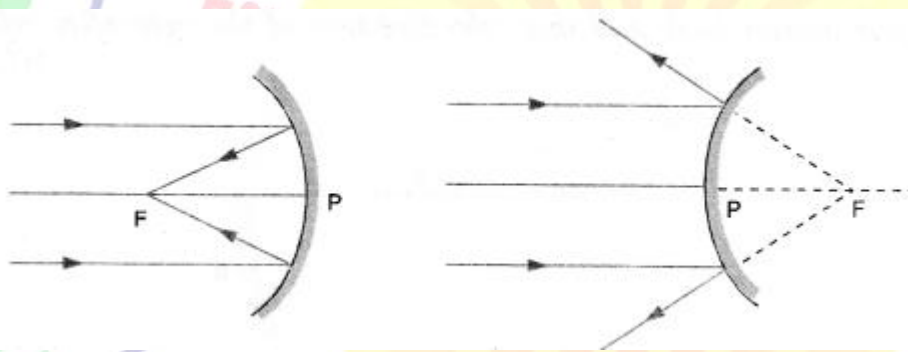

FIGURE 28

8. Answer:

(i) Reflected rays are shown in figures.



(ii) The point where the reflected rays of light meet or appear to meet on the principal axis is known as principal focus F of the concave mirror or convex mirror.

? Long Answers:

1. Answer:

(a)

- A converging or convex lens forms real and magnified image of an object, when the object is placed between F_1 and $2F_1$
- A converging lens forms a virtual magnified image of an object, when the object is placed between the focus and optical center of the converging lens.

(b)

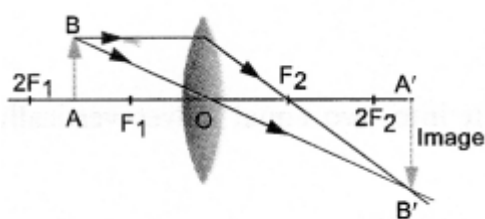

FIGURE 54

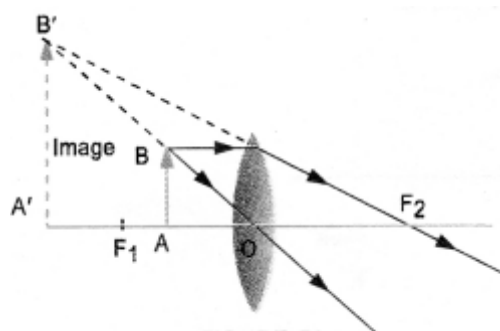

FIGURE 56

(c)

Focal length of each half will be equal to the focal length of the lens. If converging lens of focal length f is cut into two equal halves as shown in figure



then the focal length of each half = f .

Intensity of the image formed \propto (aperture of the lens)². Aperture of each cut half of the lens is $\frac{1}{2}$ times aperture of the lens. Hence, intensity of the image formed by half lens will decrease.

2. Answer:

i. Concave mirror forms the image having same size as the object if object is placed at the center of curvature

of the mirror i.e. object distance = $2f$ Therefore, for S.No. 3, concave mirror forms the required image.

ii. Concave mirror is used as a make-up mirror if the image of the face is magnified. This happens if the face or object is placed between F and $2F$. Therefore, for S. No. 2, concave mirror is used as a make-up mirror.

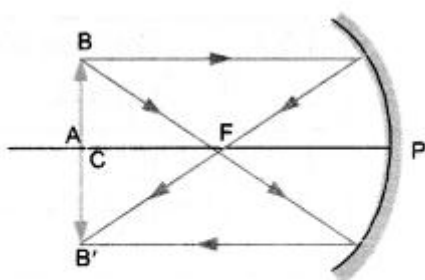

FIGURE 20

iii.

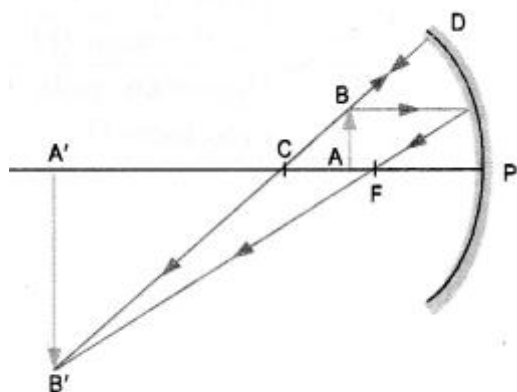

FIGURE 21

? Assertion Reason Answer:

1. (a) Both A and R are true, and R is correct explanation of the assertion.

Explanation:

The image formed in a plane mirror is at the same distance behind the mirror as the object is in the front of the mirror. Image and the object are at equal distances from a plane mirror.

2. (d) A is false, but R is true.

Explanation:

The size of the image does not affect the nature of the image, except that a bigger image as it gathers more tight rays due to wider aperture.

? Case Study Answer:

1. i (a) Towards the normal.

Explanation:

When, a ray of light travels from air to glass, it bends towards the normal.

- ii. (c) 90°

Explanation:

No bending of light occurs when light is incident normally or perpendicularly on a boundary of two media since angle of incidence and angle of refraction both are zero.

- iii. (c) Remains same

Explanation:

When light goes from one medium to other medium, its frequency does not change.

- iv. (a) Increases.

Explanation:

The speed of light increases when light passes from glass to water as water is optically rarer medium.

- v. (a) Shallower

Explanation:

The bottom of a pool of water appears to be less deep than it actually is due to refraction.

2. i (a) At focus

Explanation:

When an object is placed at infinity of convex lens, image will be formed at focus F.

- ii. (b) Virtual and inverted

Explanation:

Virtual and inverted image is formed, when object is placed at focus of the concave lens.

- iii. (c) Highly magnified

Explanation:

When object is placed at focus of a convex lens, highly enlarged or magnified image is formed.

- iv. (b) At 2 F on the other side

Explanation:

When an object is placed at distance 2F in front of a convex lens, then the image formed is at a distance 2F on the other of the lens.

- v. (a) Anywhere between centre and infinity

Explanation:

Image is formed between focus and optical centre when the object is placed anywhere between optical centre and infinity.