

CHEMISTRY

Chapter 4: Structure of the Atom

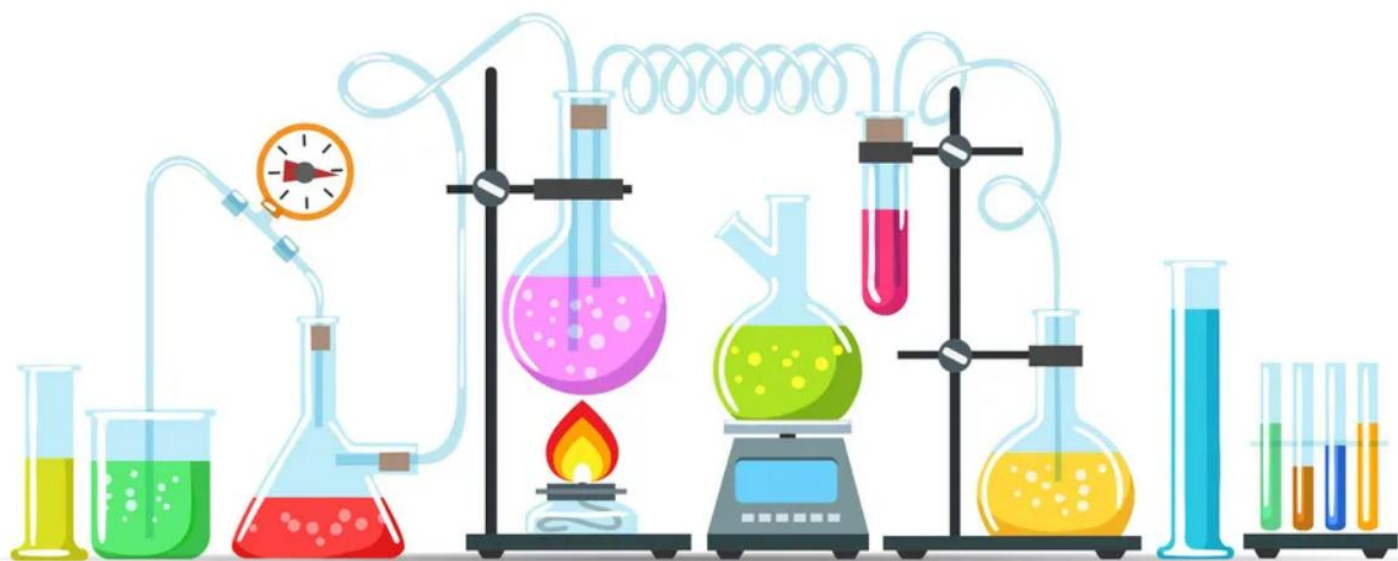

Structure of the Atom

Charged Particles in Matter

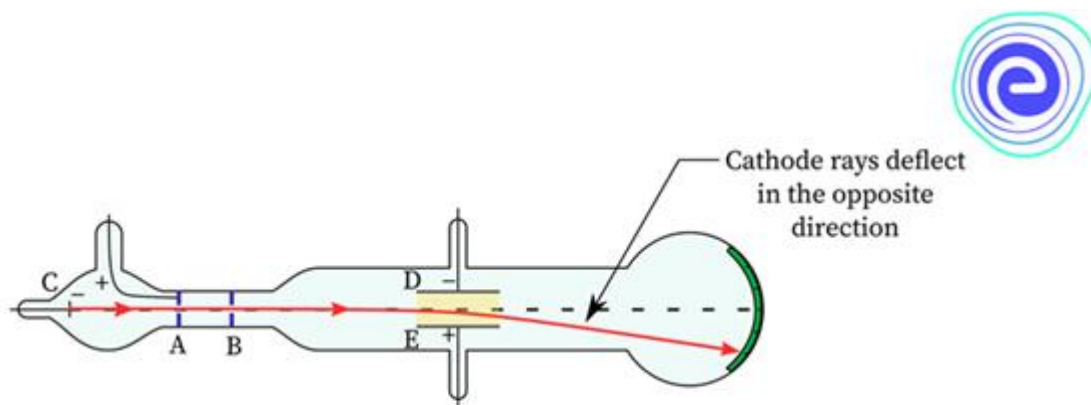

The phenomenon of static electricity and conduction of electricity through some substances hints at the presence of charged particles in matter.

Discovery of the Electron

- J.J. Thomson performed an experiment by passing electricity at a high voltage through a discharge tube containing a gas at a very low pressure. A green fluorescence was seen emitting out from the other end of the discharge tube.
- This fluorescence is the result of rays emitted from the cathode (negative plate) towards the anode (positive plate) in the discharge tube. Hence, these rays are called cathode rays.
- From his experiment, Thomson arrived at the conclusion that cathode rays are nothing but a stream of negatively charged particles. These negatively charged particles are called **electrons**.

Discovery of the Proton

- A German scientist, E. Goldstein in 1886, modified the discharge tube and passed electric current through it.
- He found that the positively charged rays were emitted from the anode in the discharge tube. These rays were called **canal rays**.
- When an electric field was applied, these rays deflected towards the negatively charged plate. Thus, Goldstein concluded that an atom contains positively charged particles along with electrons.
- These positively charged particles were named as **protons** by a British scientist, Ernest

Rutherford.

- Canal rays were also called **anode rays** since they were emitted from the anode (electrode connected to the positive terminal of high voltage source) in the gas discharge experiments using a perforated cathode.

Discovery of the Neutron

- In 1932, James Chadwick observed that when beryllium was exposed to α -particles, different kinds of particles were emitted.
- These particles had about the same mass as protons and carried no electrical charge. Hence, Chadwick named these particles **neutrons**.
- These were present in the nucleus along with protons.
- Neutrons are present in the nucleus of all the atoms except hydrogen.
- As protons and neutrons are both present in the nucleus, they are together known as **nucleons**

Properties of Electron, Proton and Neutron

Sub-atomic particle	Symbol	Location in the atom	Relative Charge	Relative mass	Actual mass	Absolute Mass
Electron	e^-	Outside the nucleus	-1	$\frac{1}{1840}$ a.m.u.	9.1×10^{-31} kg	9×10^{-28} grams
Proton	P^+	Inside the nucleus	+1	1 a.m.u.	1.673×10^{-27} kg	1.6×10^{-24} grams
Neutron	n	Inside the nucleus	0	1 a.m.u.	1.675×10^{-27} kg	1.6×10^{-24} grams

The Structure of an Atom

Thomson's Model of an Atom

- Thomson's model of an atom is popularly known as the plum pudding or Christmas pudding model of an atom.

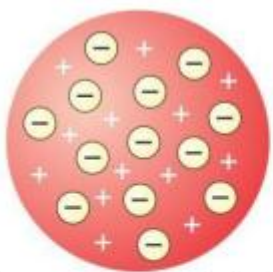

Thomson's model of an Atom



Plum pudding

- According to the Thomson's plum pudding model, an atom is a positively charged sphere in which the electrons are embedded.
- The negative charge of the electrons and the positive charge of the sphere is equal in magnitude. Thus, an atom as a whole is electrically neutral.
- But, his model could not explain the results of experiments carried out by other scientists such as Rutherford and Bohr.

Limitations of Thomson's Atomic Model

- Although Thomson's atomic model explained why an atom is electrically neutral, it could not explain the distribution of electrons in the atom.
- If we accept that electrons are embedded in the positive charge, then the opposite electric charges should cancel each other out and the charged sphere would be uncharged.

Thomson's model could not explain why different elements have different chemical properties.

Rutherford's Model of an Atom

In 1911, Earnest Rutherford, a scientist from New Zealand, overturned Thomson's atomic model by his gold foil experiment.

Rutherford's Scattering Experiment

- Rutherford selected a gold foil as he wanted a very thin layer.
- The gold foil used by Rutherford was 0.004 millimetres in thickness. That is, the foil was about 1000 atoms thick.
- In his experiment, fast moving α -particles (alpha particles) were made to fall on a thin gold foil.
- The α -particles are helium ions with a +2 charge. Their atomic mass is 4 u. Hence, a high velocity beam of α -particles has a lot of energy.
- These particles were studied by means of flashes of light they produced on striking a zinc sulphide screen.

- The α -particles are much heavier than the sub-atomic particles present in gold atoms.
- Hence, he expected the α -particles to pass through the gold foil with little deflection and strike the fluorescent screen.

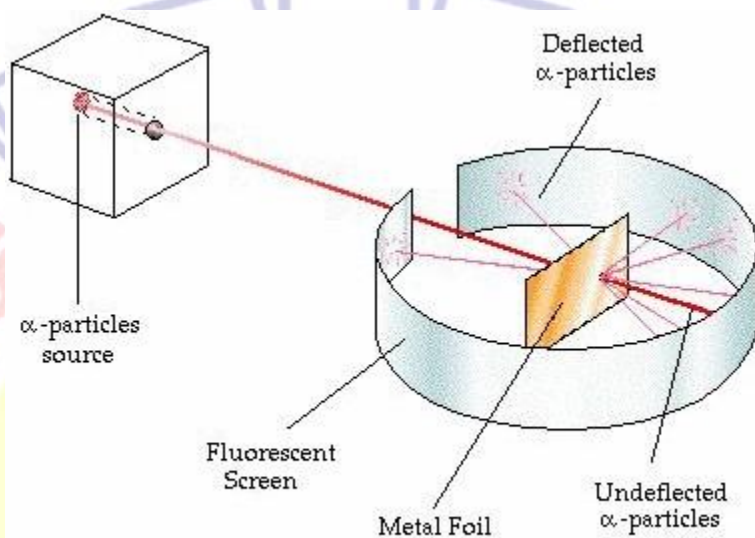

Rutherford's α -Particle Scattering Experiment

But the observations he made were quite unexpected.

Explanation of the Results of Rutherford's Gold Foil Experiment

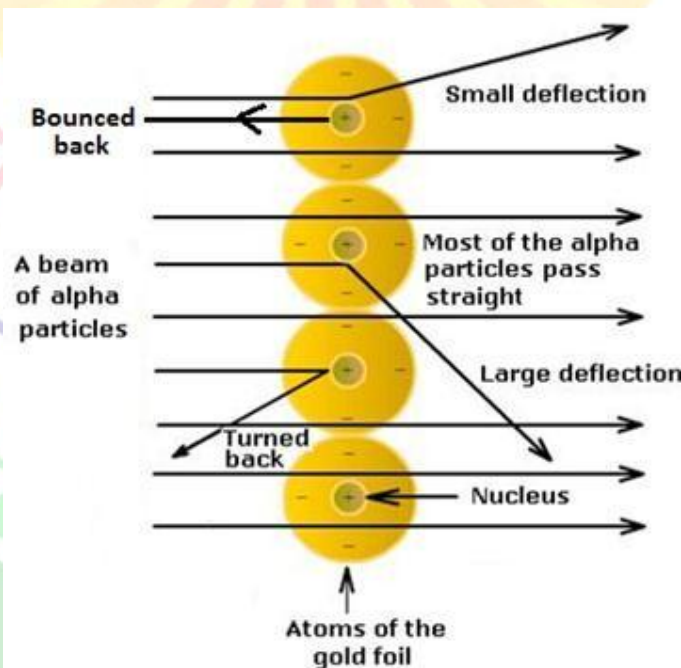

Deflection of α -particles from the Gold foil

- Rutherford postulated that the atom must contain large empty spaces as most of the α -particles passed through it without getting deflected.
- Some α -particles were deflected by the foil through small angles, while some were deflected through very large angles. Thus, Rutherford concluded that the positively

charged particles in an atom must be concentrated in a very small space.

- One out of every 12,000 particles were deflected through 180° showing a full rebound. Thus, Rutherford came to the conclusion that all the positive charges of the atom and most of the mass of the atom is concentrated in a very small volume within the atom.
- Rutherford named this small space inside the atom as the **nucleus of the atom** or the **atomic nucleus**.
- On the basis of these observations, Rutherford calculated that the atomic nucleus is 10^5 times smaller than the total area of the atom.
- The radius of the atom is 10^{-8} centimetres while the radius of the nucleus is 10^{-13} centimetres.
- Thus, we can say that the atom is relatively hollow with a heavy nucleus at its centre. The electrons arranged around the nucleus possess negligible mass.
- Based on his observations, he formulated the **Theory of atom**.

Rutherford's Atomic Model

- Based on the results of the α -particle scattering experiments, Rutherford put forth his atomic model.
- An atom contains a positively charged centre called the nucleus of the atom. Almost all the mass of the atom is concentrated in the nucleus.
- The electrons of the atom revolve around the nucleus in fixed, circular orbits.
- The size of the nucleus is many times smaller than the size of the atom. The nucleus of

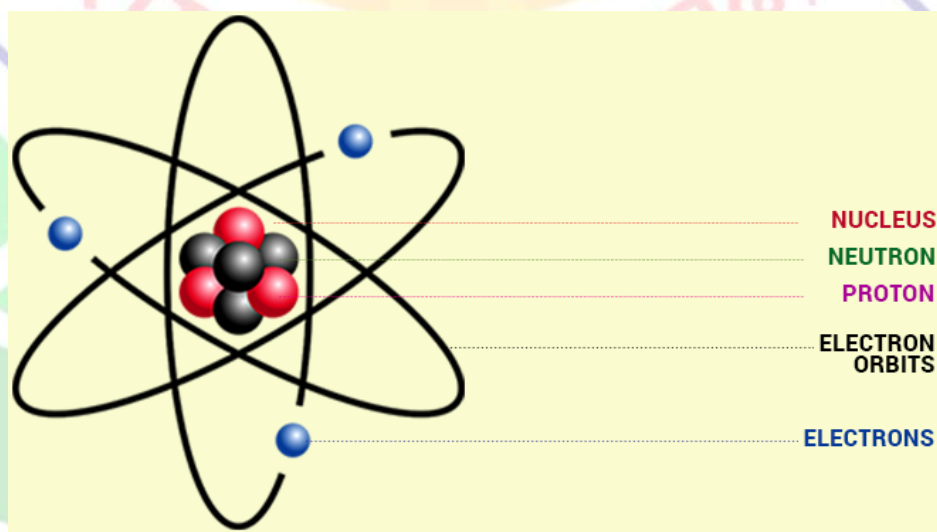

an atom is 10,000 times smaller than the atom.

Drawbacks of Rutherford's Model of an Atom

- Rutherford's atomic model could not explain how moving electrons could remain in their

orbits.

- Any charged particle during acceleration would radiate energy, and while revolving, it would lose its energy and eventually fall into the nucleus.
- This means that the atom would be highly unstable.
- But, matter is composed of stable atoms.
- Thus, the major drawback of Rutherford's atomic model was that it could not explain the stability of atoms.

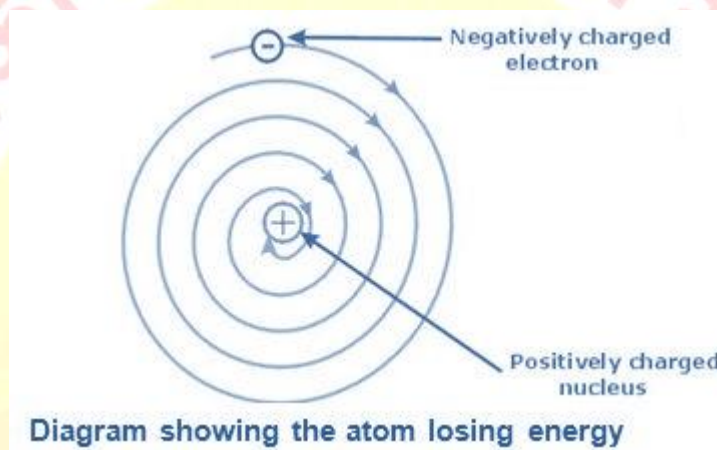

Bohr's Model of an Atom

- Niels Bohr, revised Rutherford's atomic model and put forth the following suggestions:
- Neils Bohr proposed that the electrons possess a specific amount of energy which allows them to revolve around the nucleus.

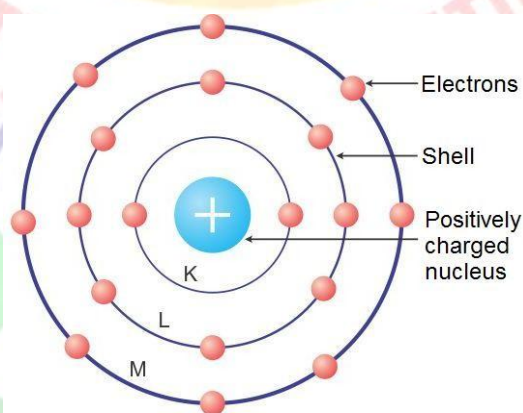

Niels Bohr's Atomic Model

- The electrons are confined to these energy levels. While revolving in these discrete orbits, the electrons do not radiate energy. Hence, these orbits are also known as **stationary orbits** or **stationary shells**. Smaller the size of the orbit, smaller is its energy.
- As we move away from nucleus, the energy of the orbit increases progressively.

- The transfer of an electron from one orbit to another is always accompanied with absorption or emission of energy.
- When an electron jumps from a lower energy level to a higher energy level, it **absorbs energy**.
- When an electron returns from a higher energy level to a lower energy level, it **emits energy**.

Distribution of Electrons in the Orbits

- According to Bohr's model, electrons occupy certain stable orbits or shells. Each shell has a definite energy.
- These orbits or shells are represented by the letters K, L, M, N... or the numbers 1, 2, 3, 4...
- The maximum number of electrons present in the shell is given by the formula $(2n^2)$, where n is the orbit number or shell number.
- The maximum number of electrons in different shells is as follows:
 - ✓ The first orbit or K shell will have $2 \times 1^2 = 2$ electrons.
 - ✓ The second shell will have $2 \times 2^2 = 8$ electrons.
 - ✓ The third shell will have $2 \times 3^2 = 18$ electrons.
 - ✓ The fourth shell will have $2 \times 4^2 = 32$ electrons and so on.
- The maximum number of electrons which can be accommodated in the outermost orbit is 8.
- The orbits or shells are filled in a step-wise manner.
- Electrons are not accommodated in a given shell unless the inner shells are filled.

Octet Rule

The Octet rule states that- 'The maximum number of electrons that the outermost shell of an electrically neutral and chemically stable atom can have is 8.'

Exception: If the atom has only one shell, it can hold only 2 electrons. For example, hydrogen and helium can have only 2 electrons (duplet).

Examples: (Distribution of electrons)

Electronic configuration

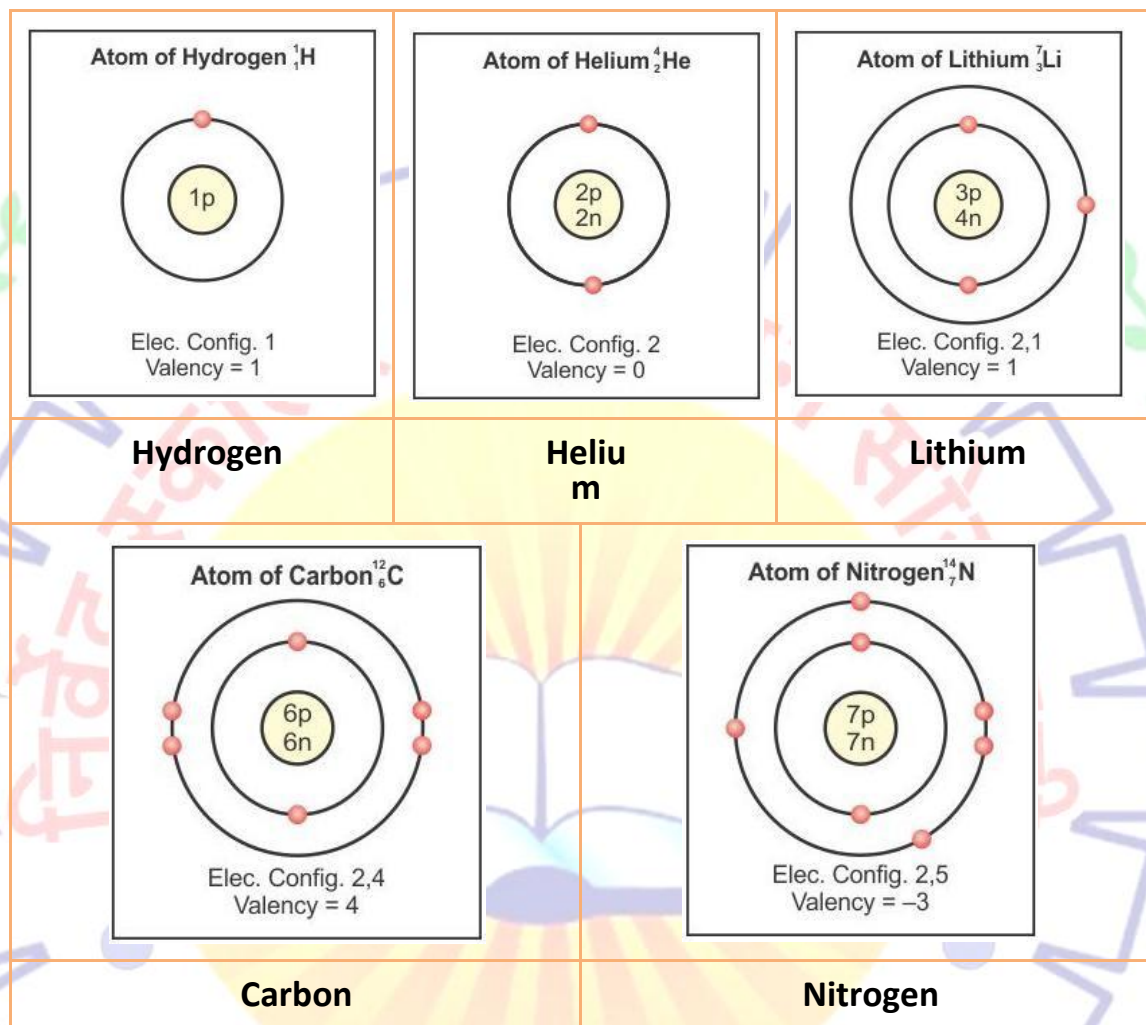

- The symbol of hydrogen is H and its atomic number is 1. The total number of electrons is 1. Therefore, the electronic configuration is also 1. Since it has only one electron, it will occupy the K shell.

K	L	M	N
1	-	-	-

- The symbol of helium is He and its atomic number is 2. Therefore, the electronic configuration is also 2. Both these electrons will occupy the K shell (**duplet**).

K	L	M	N
2	-	-	-

- The symbol of lithium is Li. The atomic number is 3. Therefore, the electronic configuration is (2, 1). This means that there are two electrons in the K shell and one electron in the L shell.

K	L	M	N
2	1	-	-

- The symbol of carbon is denoted by the capital letter C. The atomic number is 6. The number of electrons present in carbon atom is 6. Therefore, the electronic configuration is (2, 4). This means that there are 2 electrons in the K shell and 4 electrons in the L shell.

K	L	M	N
2	4	-	-

- The symbol of nitrogen is N and its atomic number is 7. The number of electrons is 7. Therefore, the electronic configuration is (2, 5). This means that there are two electrons in the K shell and 5 electrons are in the L shell.

K	L	M	N
2	5	-	-

- All noble gases except helium have eight electrons in the outermost shell. This arrangement is known as an **octet**.

Electronic Configuration of Elements

- The energy of every electron depends on the shell it occupies.
- Electrons in the K shell have minimum energy. Electrons in subsequent shells have higher energies.
- The arrangement of electrons of each element is called the electronic configuration of the element.

Valency

- The valency of an element represents the combining capacity of the element.
- It can also be defined as the number of electrons lost, gained or shared by its atom during a chemical combination.

Valence Shell

The outermost shell or orbit of an atom is known as the valence shell or valence orbit.

Valence Electrons

- The electrons present in the outermost valence shell of an atom are called valence electrons.
- The number of valence electrons varies from 1 to 8 for the atoms of different elements.
- The valence electrons of an atom determine the valency of that element.

Atomic Number and Atomic Mass Number

- The number of protons present in the nucleus of an atom is the atomic number of that atom. It is represented by the **symbol Z**.

$$\text{Atomic number (Z) = Number of protons (p)}$$

- All atoms of an element have the same atomic number. The number of protons and electrons in an atom is equal. Thus, the atom of an element is electrically neutral.
- Atomic mass number is defined as the sum of the number of protons and neutrons contained in the nucleus of an atom of that element. It is denoted by the **symbol A**.

$$\text{Atomic mass number (A) = Number of protons (p) + Number of neutrons (n)}$$

The atomic number, atomic mass number and symbol of an element are

written as - $\frac{\text{Mass number}}{\text{Atomic number}}X$ or $\frac{Z}{A}X$

Isotopes

- Atoms of the same element differing in the number of neutrons in their nuclei are known as **isotopes**. Thus, isotopes of an element have the same atomic number but different atomic mass numbers.
- Isotopes are identified by their mass numbers.
- For example, the isotopes of carbon are referred to as carbon-12, carbon-13 and carbon-14.
- Isotopes of an element have **similar chemical properties but different physical properties**.

Average Atomic Mass of Chlorine

The isotopes of chlorine, found in nature are in the ratio 3 : 1.

Examples of Isotopes		
Element	Number of Isotopes	
Hydrogen	Three	Protium (${}^1_1\text{H}$) Deuterium (${}^2_1\text{H}$) Tritium (${}^3_1\text{H}$)
Carbon	Three	${}^{12}_6\text{C}$ ${}^{13}_6\text{C}$ ${}^{14}_6\text{C}$
Oxygen	Two	${}^{16}_8\text{O}$ ${}^{17}_8\text{O}$
Uranium	Two	${}^{235}_{92}\text{U}$ ${}^{238}_{92}\text{U}$

So, in any sample of chlorine, ${}^{35}_{17}\text{Cl}$ will constitute 75% and ${}^{37}_{17}\text{Cl}$ will constitute 25%.

The proportion in which the isotopes are found in the nature is always constant. Therefore, in any sample of chlorine, the average atomic mass will be

Average atomic mass of chlorine

$$= (35 \times 75/100) + (37 \times 25/100)$$

$$= 105/4 + 37/4$$

$$= 142/4$$

$$= 35.5 \text{ u}$$

The average atomic mass of chlorine is equal to 35.5 u.

Radioactive Isotopes

- Isotopes can be stable or unstable depending on the presence of extra neutrons in their nuclei.
- The unstable isotopes which emit various types of radiations are known as radioactive isotopes.
- A few commonly used radioactive isotopes are carbon-14, arsenic-74, sodium-24, iodine-131, cobalt- 60 and uranium-235.

Applications of Isotopes

- Radioactive isotopes are used in nuclear reactors as a fuel. The nuclear reactors are used to generate electricity.
- Uranium-235 isotope is the fuel of choice for nuclear power plants.
- They are also used as diagnostic tools in medicine.
- Cobalt-60 is the isotope of choice for radiotherapy.
- Phosphorus-30 is used in the treatment of leukemia or blood cancer.
- Iodine-131 radioisotope, used as a 'tracer', is injected into the body to check the activity of the thyroid gland. It helps in detecting the amount of iodine taken up by the thyroid gland. It is an important tool in the diagnosis and treatment of diseases such as goitre.

Isobars

The atoms of different elements having different atomic numbers but the same mass number are known as isobars.

Examples of Isobars

Isobars	Number of protons	Number of neutrons	Mass number
Chlorine-37	17	20	37
Argon-37	18	19	37
Cerium-76	32	44	76
Selenium-76	34	42	76
Iron-58	26	32	58
Nickel-58	27	31	58

Class : 9th Science
Chapter- 4 : Structure Of The Atom

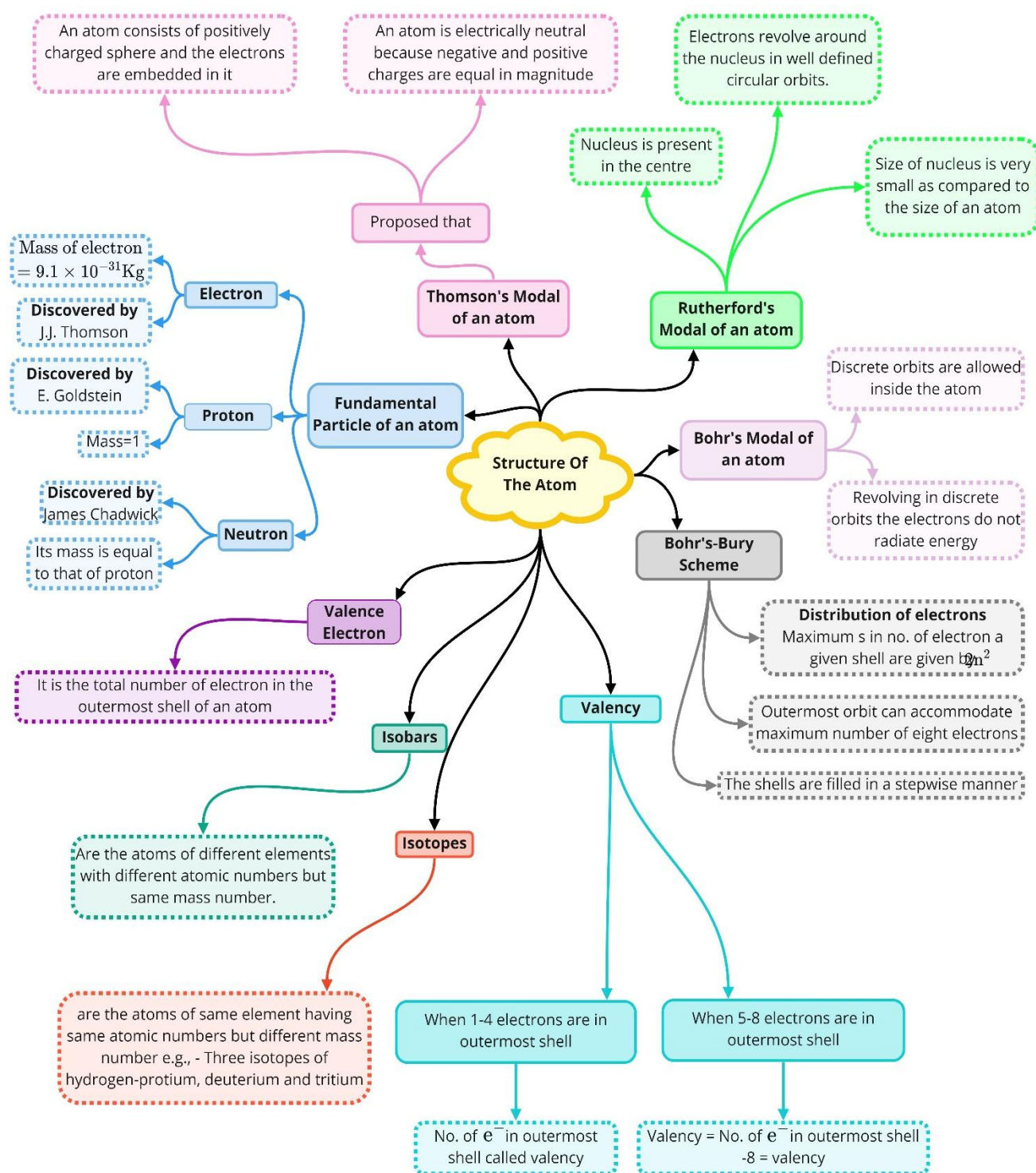

Important Question

➤ Multiple Choice Questions:

1. Who discovered the electron?

- (a) Rutherford
- (b) Chadwick
- (c) Thomson
- (d) Goldstein

2. Which isotope is used in the nuclear power plants to generate electricity?

- (a) Uranium 235
- (b) Iodine 131
- (c) Cobalt 60
- (d) Uranium 238

3. Why was the Thomson's Model of an atom failed?

- i. It could not explain the screening of negative charges from that of positive
- ii. It did not tell about the presence of electrons
- iii. It did not give an idea about the discrete energy levels
- iv. It explained the atom as a whole to be electrically neutral

Choose the correct option from the following:

- (a) Only (iii)
- (b) Both (i) & (iii)
- (c) Only (i)
- (d) Both (ii) & (iv)

4. What was the source of alpha particles in Rutherford scattering experiment?

- (a) Hydrogen nucleus
- (b) Argon nucleus
- (c) Helium nucleus
- (d) None of these

5. What property of an element determines its chemical behaviour?

- (a) Size of an element
- (b) Valency of an element

(c) Molar mass of the element

(d) None of these

6. Which of the following does not match the characteristics of an Isotope?

(a) Isotopes of some elements are radioactive

(b) Isotopes are the atoms of different elements

(c) Isotopes differ in number of neutrons

(d) Isotopes have similar chemical properties

7. Which of the two will be chemically more reactive, Sulphur(S) with atomic number 16 or Chlorine (Cl) with atomic number 17?

(a) Chlorine

(b) Sulphur

(c) Both are equally reactive

(d) Can't say

8. Which of the following elements does not exhibit the electrovalency?

(a) Sodium

(b) Calcium

(c) Carbon

(d) Chlorine

9. Which of the following statements is incorrect about the structure of an atom?

i. The whole mass of an atom is concentrated in the nucleus

ii. The atom is an indivisible particle

iii. The atom as a whole is neutral

iv. All the atoms are stable in their basic state

Choose the right option among the following:

(a) (i) and (iii)

(b) only (ii)

(c) (ii) and (iv)

(d) none of these

10. Which scientist gave the concept of fixed energy levels around the nucleus?

(a) Ernest Rutherford

(b) Neils Bohr

- (c) J.J.Thomsan
(d) None of these

11. What prevents an atom from being collapsed?

- (a) The nuclear forces
(b) Movement of electrons in discrete energy levels
(c) The electron-electron repulsions
(d) All of these

12. Which of the following pairs are isobars?

- (a) ${}_{17}\text{Cl}^{35}$ & ${}_{17}\text{Cl}^{37}$
(b) ${}_{18}\text{Ar}^{40}$ & ${}_{20}\text{Ca}^{40}$
(c) ${}_{6}\text{C}^{12}$ & ${}_{6}\text{C}^{14}$
(d) None of these

13. Which of the following is an incorrect statement in reference with observation in Rutherford's α -particle scattering experiment?

- (a) Some of the α -particles rebound after hitting the gold foil
(b) Some of the particles deflected from their path
(c) Some of the particles not pass through the gold foil
(d) Most of the particles pass straight through the gold foil

14. Which radioactive element is used in the treatment of cancer?

- (a) Iodine-131
(b) Uranium-234
(c) Plutonium-239
(d) Cobalt-60

15. Why do most of the elements try to participate in the chemical combinations?

- i. To gain more electrons
ii. To achieve Inert Gas configuration
iii. To complete their octet
iv. To complete their inner shells

Choose the correct option among the following

- (a) Both (i) & (iii)
(b) Both (ii) & (iii)

- (c) Only (ii)
 (d) Both (i) & (iv)

➤ Very Short Question:

1. Draw the atomic structure of hydrogen atom.
2. Why are some elements chemically inert?
3. Why is atom electrically neutral?
4. What is the charge and mass of α -particles?
5. What are valence electrons?
6. An atom has atomic number 12, what is its valency and name the element?
7. Find the number of neutrons in ${}^{27}_{13}\text{X}$.
8. Where is the mass of atom concentrated?
9. Name two elements with same number of protons and neutrons?
10. Draw the atomic structure of sodium atom.

➤ Short Questions:

1. Name the scientist who discovered protons and neutrons in an atoms.
2. What is the contribution of Bohr and Bury together in the structure of atom's explanation?
3. Draw the atomic structure of (i) an atom with same number of sub-atomic particles, (ii) an atom with same number of electrons in L and M shell.
4. What is an octate? Why would atoms want to complete their octate?
5. Find the valency of ${}^{14}_7\text{N}$ and ${}^{35}_{17}\text{Cl}$.
6. Pick up the isotopes among the following and state reason.



7. Pick up atoms which have same number of neutrons from the following:



8. What are nucleons? What is the name given to those atoms which have same number of nucleons in it?

➤ Long Questions:

1. Give an activity to understand the implications of Rutherford's a scattering experiment by a gold foil.

2. What are isotopes? State its characteristics, give uses of isotopes?
3. Explain Rutherford's α -particle scattering experiment and give its observation and conclusion drawn.

➤ Assertion Reason Questions:

1. For two statements are given- one labelled Assertion (A) and the other labelled Reason (R). Select the correct answer to these questions from the codes (a), (b), (c) and (d) as given below:
 - a. Both Assertion and Reason are correct, and reason is the correct explanation for assertion.
 - b. Both Assertion and Reason are correct, and Reason is not the correct explanation for Assertion.
 - c. Assertion is true but Reason is false.
 - d. Both Assertion and Reason are false.

Assertion: No. of electrons always equal to the proton no. of atom.

Reason: Atom is always made-up of proton and electron.

2. For two statements are given- one labelled Assertion (A) and the other labelled Reason (R). Select the correct answer to these questions from the codes (a), (b), (c) and (d) as given below:
 - a. Both Assertion and Reason are correct, and reason is the correct explanation for assertion.
 - b. Both Assertion and Reason are correct, and Reason is not the correct explanation for Assertion.
 - c. Assertion is true but Reason is false.
 - d. Both Assertion and Reason are false.

Assertion: No. of electrons always equal to the proton no. of atom.

Reason: Atoms are always made up of proton, electron, and neutron.

➤ Case Study Questions:

1. Dalton's atomic theory suggested that the atom was indivisible and indestructible. But the discovery of two fundamental particles (electrons and protons) inside the atom, led to the failure of this aspect of Dalton's atomic theory. It was then considered necessary to know how electrons and protons are arranged within an atom. For explaining this, many scientists proposed various atomic models. J.J. Thomson was the first one to propose a model for the structure of an atom.

J.J. Thomson (1856- 1940) was a British physicist, He was awarded the Nobel Prize in Physics for his work on the discovery of electrons. Thomson proposed the model of an atom to be similar to that of a Christmas pudding. The electrons, in a sphere of positive charge. We can also think of a watermelon, the positive charge in the atom is spread all over like the red edible part of the watermelon, while the electrons are studded in the positively charged sphere, like the seeds in the watermelon. Thomson proposed that: An atom consists of a positively charged sphere and the electrons are embedded in it. The negative and positive charges are equal in magnitude. So, the atom as a whole is electrically neutral.

(i) Identify the correct statement

Statement 1 – Dalton’s atomic theory suggested that the atom was indivisible and indestructible.

Statement 2 – Electrons and protons are present inside the atom.

Statement 3 – J.J. Thomson was the first one to propose a model for the structure of an atom.

Statement 4 – Protons are positively charged particle.

- (a) Only 2
- (b) Both 3 & 4
- (c) Both 1 & 2
- (d) All of the above

(ii) According to Dalton’s Atomic Theory, matter consists of indivisible _____

- (a) Molecules
- (b) Atoms
- (c) Ions
- (d) Mixtures

(iii) Who was the first to propose atomic theory?

- (a) J.J. Thomson
- (b) John Dalton
- (c) E. Rutherford
- (d) Neilsbhore

(iv) “Atom is indivisible and indestructible” why this aspect of Dalton’s atomic theory leads to the failure?

(vi) Explain the J.J. Thomson’s model for the structure of an atom?

2. Rutherford (1871-1937) was known as the 'Father' of nuclear physics. He is famous for his work on radioactivity and the discovery of the nucleus of an atom with the gold foil experiment. Ernest Rutherford was interested in knowing how the electrons are arranged within an atom. Rutherford designed an experiment for this. In this experiment, fast moving alpha (α)-particles were made to fall on a thin gold foil. On the basis of his experiment, Rutherford put forward the nuclear model of an atom, which had the following features:

- There is a positively charged centre in an atom called the nucleus. Nearly all the mass of an atom resides in the nucleus.
- The electrons revolve around the nucleus in circular paths.
- The size of the nucleus is very small as compared to the size of the atom.

Drawbacks of Rutherford's model of the atom: The revolution of the electron in a circular orbit is not expected to be stable. Any particle in a circular orbit would undergo acceleration. During acceleration, charged particles would radiate energy. Thus, the revolving electron would lose energy and finally fall into the nucleus. If this were so, the atom should be highly unstable and hence matter would not exist in the form that we know. We know that atoms are quite stable.

(i) Which of the following scientist was known as the 'Father of nuclear physics?'

- (a) J.J. Thomson
- (b) John Dalton
- (c) E. Rutherford
- (d) Neilsbhone

(ii) Positively charged centre in an atom is termed as

- (a) Nucleus
- (b) Molecule
- (c) Atom
- (d) Protons

(iii) Identify the correct statement

Statement 1 – Positively charged centre in an atom called the nucleus.

Statement 2 – The electrons revolve around the nucleus in circular paths.

Statement 3 – Nearly all the mass of an atom resides in the nucleus.

Statement 4 – The size of the nucleus is very small as compared to the size of the atom.

- (a) Only 2
- (b) Both 3 & 4

- (c) Both 1 & 2
- (d) All of the above

(iv) Write the features of Rutherford's nuclear model of an atom?

(v) Define Nucleus.

✓ Answer Key-

➤ Multiple Choice Answers:

1. (c) Thomson
2. (a) Uranium 235
3. (b) Both (i) & (iii)
4. (c) Helium nucleus
5. (b) Valency of an element
6. (b) Isotopes are the atoms of different elements
7. (a) Chlorine
8. (c) Carbon
9. (c) (ii) and (iv)
10. (b) Neils Bohr
11. (b) Movement of electrons in discrete energy levels
12. (b) $^{18}\text{Ar}40$ & $^{20}\text{Ca}40$
13. (a) Some of the α -particles rebound after hitting the gold foil
14. (d) Cobalt-60
15. (b) Both (ii) & (iii)

➤ Very Short Answers:

1. Answer:

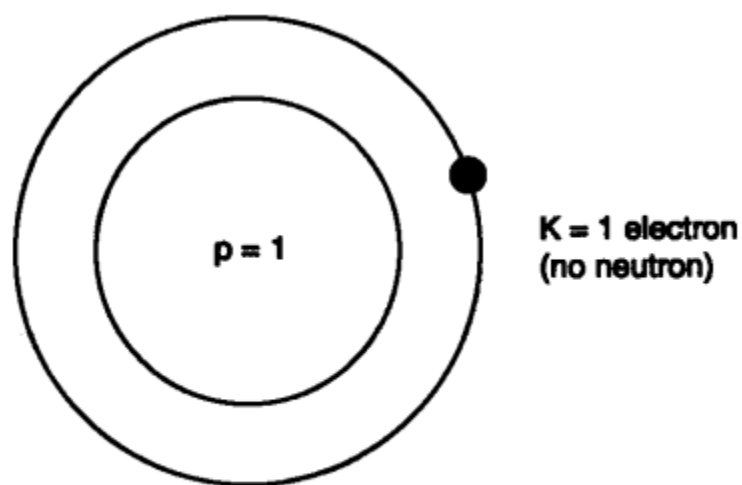

Hydrogen atom

2. Answer: Because their outermost shell is completely filled.
3. Answer: It has same number of protons and electrons, (positive charge = negative charge).
4. Answer: Charge is + 2
Mass is 4 a.m.u.
5. Answer: Electrons present in the outermost shell of an atom are called valence electrons.
6. Answer: Atomic number = 12
 \therefore Protons = Electrons = 12 Electrons Configuration = K L M -2 8 2
 \therefore Valency = 2
 Element is magnesium.
7. Answer: Mass number = 27
 $\therefore p + n = 27$ $p = 13$, (Atomic No. = Number of protons)
 $\therefore 13 + n = 27$
 $\therefore n = 14$
 \therefore Neutron = 14
8. Answer: Mass of an atom is concentrated in nucleus.
9. Answer: Carbon (Protons = Neutrons = 6)
Oxygen (Protons = Neutrons = 8)
10. Answer:

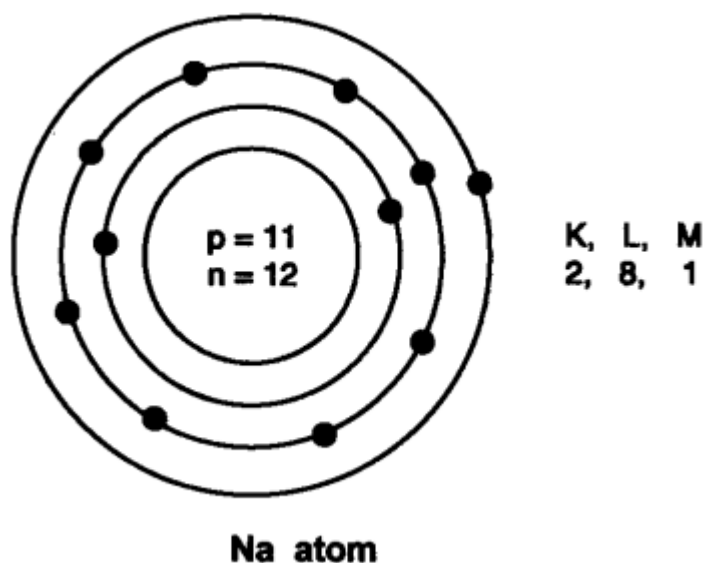

➤ Short Answer:

1. Answer: Protons were discovered by E. Goldstein in 1866 and neutrons were discovered by J. Chadwick in 1932.
2. Answer: Both Bohr and Bury gave the distribution of electrons into different atoms by giving the formula $2n^2$, where n = shell number.
3. Answer: (i) An atom with same number of sub-atomic particles is ${}^{24}\text{He}$
 No. of protons = 2
 No. of electrons = 2

No. of neutrons = 2

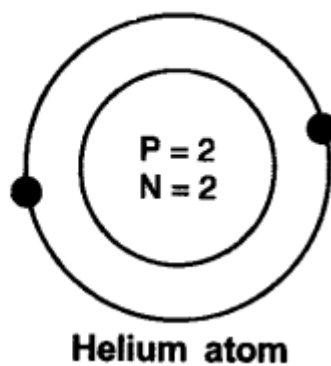

(ii) An atom with L and M shell filled \rightarrow K L M- 2 8 8

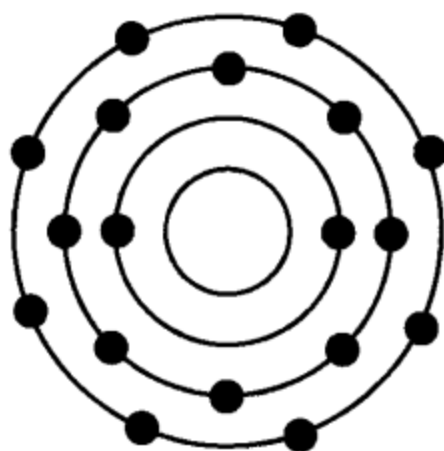

Argon

4. Answer: When the outermost shell of an atom i.e., L, M or N are completely filled with 8 electrons in the shell, it is said an octate. Atoms would want to complete their octate because they want to become stable.
5. Answer: The atomic number of nitrogen = 7, No. of protons = 7, No. of electrons = 7
 Electronic configuration = K L M = 2 5 –
 Valency = 3
 Because either it will gain three electrons or share 3 electrons to complete its octate.
 The atomic number of chlorine = 17, p = 17, e=17
 Electronic configuration = K L M= 2 8 7
 Valency = 1
 Because it will gain 1 electron to complete its octate.
6. Answer: The isotopes are $^{35}_{17}\text{X}$ and $^{37}_{17}\text{X}$ as both the atoms show same atomic number but different mass number.
7. Answer:

$^{23}_{11}\text{Y}$ and $^{24}_{12}\text{Y}$ – have same number of neutrons, 12 in each.

$^{28}_{14}\text{Y}$ and $^{27}_{13}\text{Y}$ – have same number of neutrons, 14 in each.

8. Answer: Protons and neutrons present in the nucleus are called nucleons Isobaric elements have same number of nucleons in it.

<i>E.g.,</i>	Element	Protons	Neutrons	(Protons + Neutrons)
	Argon	18	22	40
	Calcium	20	20	40
	Potassium	19	21	40

➤ Long Answer:

1. Answer: To understand the implications of Rutherford's α -particle scattering experiment:

Activity: Let a child stand in front of a wall with his eyes closed. Let him throw stones at the wall from a distance. He will hear sound for each strike of stone on the wall. This is like a nucleus of the atom. But if a blind-folded child has to throw stones at a barbed-wire fence, most of the stones would not hit the fencing and no sound would be heard.

This is because there are lots of gap in the fence which allows the stone to pass through them. This is like empty space in an atom through which α -particles will pass through.

Based on the above activity and similar reasoning Rutherford concluded the α -particle scattering experiment as:

- Most of the space inside the atom is empty as α -particles passed through the foil.
- Very few particles deflected from their path, this show that positive charge occupies less space.
- A very small fraction of α -particles are deflected by 180° , this shows that all the positive charge and mass of the gold atom were concentrated in a very small volume within the atom.

2. Answer: Atoms of same element with same atomic number but different mass number are isotopes.

Characteristics:

- Physical properties of the isotopes are different e.g. mass, density.
- Chemical properties of the isotopes are same due to same number of electrons.

Uses:

- Uranium isotope is used as a fuel in nuclear reactor (U-235).
- Cobalt isotope is used for treatment of cancer (Co-60).
- Iodine isotope is used in the treatment of goitre.

3. Answer: Rutherford's α -particle scattering experiment:

Fast moving α -particles were made to fall on a thin gold foil. Particles have + 2 charge and $4u$ mass, and considerable amount of energy.

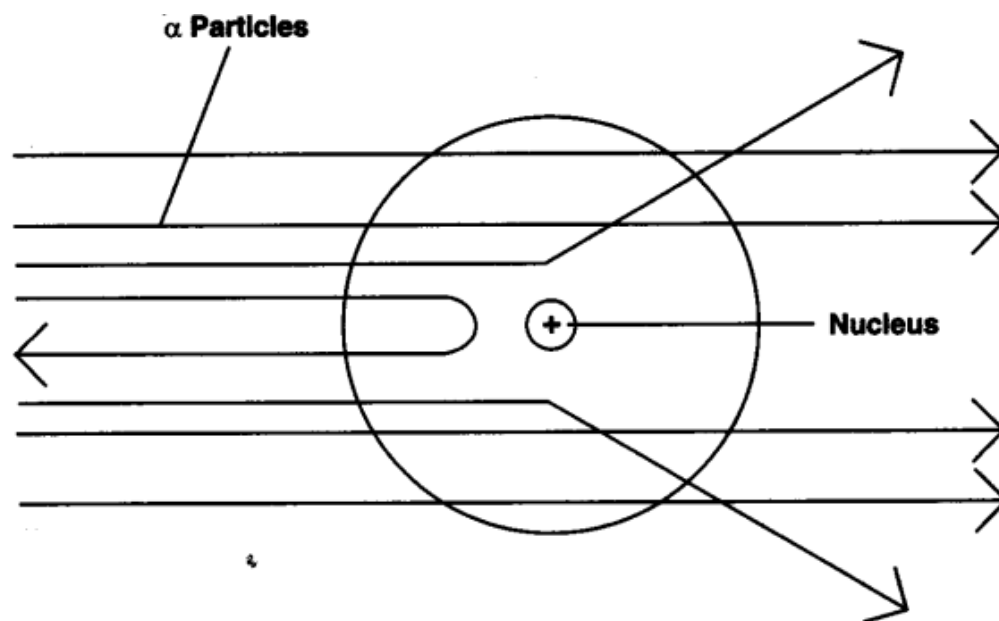

Observations:

- Most of the α -particles passed straight through the foil.
- Some of the α -particles were deflected by small angles by the foil.
- One out of every 12000 particles rebounded.

Conclusion from observation:

- Most of the space inside the foil is empty.
- Positive charge of atom occupies very less space.
- Mass of the atom is concentrated in the centre with all positive charge concentrated in small volume within the atom.

➤ Assertion Reason Answer:

1. (c) Assertion is true but Reason is false.
2. (b) Both Assertion and Reason are correct, and Reason is not the correct explanation for Assertion.

➤ Case Study Answers:

1.

(i) (d) All of the above

(ii) (b) Atoms

(iii) (b) John Dalton

(iv) Dalton's atomic theory suggested that the atom was indivisible and indestructible. But the discovery of two fundamental particles (electrons and protons) inside the atom, led to the failure of this aspect of Dalton's atomic theory.

(v) Thomson was the first one to propose a model for the structure of an atom:

Postulate 1: An atom consists of a positively charged sphere with electrons embedded in it.

Postulate 2: An atom as a whole is electrically neutral because the negative and positive charges are equal in magnitude

Thomson atomic model is compared to watermelon. Where he considered:

- Watermelon seeds as negatively charged particles.
- The red part of the watermelon as positively charged.

2.

(i) c

(ii) a

(iii) d

(iv) Rutherford put forward the nuclear model of an atom, which had the following features:

- There is a positively charged centre in an atom called the nucleus. Nearly all the mass of an atom resides in the nucleus.
- The electrons revolve around the nucleus in circular paths.
- The size of the nucleus is very small as compared to the size of the atom.

(v) There is a positively charged centre in an atom called the nucleus. Nearly all the mass of an atom resides in the nucleus.