

# MATHEMATICS

## QUESTION BANK

*for*

## CLASS – VIII

**CHAPTER WISE COVERAGE IN THE FORM  
MCQ WORKSHEETS AND PRACTICE QUESTIONS**

Prepared by

***M. S. KUMARSWAMY, TGT(MATHS)***

***M. Sc. Gold Medallist (Elect.), B. Ed.***

**Kendriya Vidyalaya GaCHIBOWLI**

ISAMPAL  
DEPUTY COMMISSIONER



केन्द्रीय विद्यालय संगठन, क्षेत्रीय कार्यालय,  
के. कामराज मार्ग, बेंगलूर-560 042  
KENDRIYA VIDYALAYA SANGATHAN  
REGIONAL OFFICE  
K. KAMARAJA ROAD, BANGALORE- 560042

F. DO-DC./2013-KVS(BGR)

Dated:05.09.2013

Dear Shri M.S.Kumarswamy,

It has been brought to my notice the good work done by you with regard to making question bank and worksheets for classes VI to X in Mathematics. I am pleased to look at your good work. Mathematics is one discipline which unfortunately and wrongly perceived as a phobia. May be lack of motivation from teachers and inadequate study habits of students is responsible for this state of affairs. Your work in this regard assumes a great significance. I hope your own students as well as students of other Vidyalayas will benefit by your venture. You may mail the material to all the Kendriya Vidyalayas of the region for their benefit. Keep up the good work.

**May God bless!**

**Yours sincerely,**

(Isampal)

Shri M.S.Kumarswamy  
TGT (Maths)  
Kendriya Vidyalaya  
Donimalai

Copy to: the principals, Kendriya Vidyalayas, Bangalore Region with instructions to make use of the materials prepared by Mr. M.S.Kumarswamy being forwarded separately.

**DEDICATED**  
**TO**  
**MY FATHER**  
**LATE SHRI. M. S. MALLAYYA**

**MCQ WORKSHEET-I**  
**CLASS VIII: CHAPTER - 1**  
**RATIONAL NUMBERS**

1. Associative property is not followed in \_\_\_\_\_.  
(a) whole numbers      (b) integers      (c) natural numbers      (d) rational numbers
2. \_\_\_\_\_ is the identity for the addition of rational numbers.  
(a) 1      (b) 0      (c) -1      (d)  $\frac{1}{2}$
3. \_\_\_\_\_ is the multiplicative identity for rational numbers.  
(a) 1      (b) 0      (c) -1      (d)  $\frac{1}{2}$
4. The additive inverse of  $\frac{7}{5}$  is  
(a) 1      (b) 0      (c)  $-\frac{7}{5}$       (d)  $\frac{7}{5}$
5. Zero has \_\_\_\_\_ reciprocal.  
(a) 1      (b) 2      (c) 3      (d) no
6. The numbers \_\_\_\_\_ and \_\_\_\_\_ are their own reciprocals  
(a) 1 and 0 (b) 1 and -1      (c) -1 and 0      (d) none of these.
7. The reciprocal of -5 is \_\_\_\_\_.  
(a) 5      (b) 1      (c)  $-\frac{1}{5}$       (d)  $\frac{1}{5}$
8. Reciprocal of  $\frac{1}{x}$ , where  $x \neq 0$  is \_\_\_\_\_.  
(a) 1      (b) x      (c) 0      (d) none of these
9. The product of two rational numbers is always a \_\_\_\_\_.  
(a) whole numbers      (b) integers      (c) natural numbers      (d) rational numbers
10. Simplify:  $\frac{-4}{5} \times \frac{3}{7} \times \frac{15}{16} \times \left(\frac{-14}{9}\right)$   
(a) 1      (b) 0      (c) 2      (d)  $\frac{1}{2}$
11. The sum of the rational numbers  $\frac{-5}{16}$  and  $\frac{7}{12}$  is  
(a)  $\frac{-7}{48}$       (b)  $\frac{-11}{30}$       (c)  $\frac{13}{48}$       (d)  $\frac{1}{3}$
12. What number should be added to  $\frac{7}{12}$  to get  $\frac{4}{15}$  ?  
(a)  $-\frac{19}{60}$       (b)  $-\frac{11}{30}$       (c)  $\frac{51}{60}$       (d)  $\frac{1}{20}$

**MCQ WORKSHEET-II**  
**CLASS VIII: CHAPTER - 1**  
**RATIONAL NUMBERS**

1. The reciprocal of a positive rational number is \_\_\_\_\_.  
(a) negative                      (b) positive      (c) zero                      (d) none of these
  
2. What number should be subtracted from  $-\frac{3}{5}$  to get  $-2$ ?  
(a)  $-\frac{7}{5}$       (b)  $-\frac{13}{5}$       (c)  $\frac{13}{5}$                       (d)  $\frac{7}{5}$
  
3. Which of the rational numbers  $\frac{-11}{28}$ ,  $\frac{-5}{7}$ ,  $\frac{9}{-14}$ ,  $\frac{29}{-42}$  is the greatest?  
(a)  $\frac{-11}{28}$       (b)  $\frac{-5}{7}$                       (c)  $\frac{9}{-14}$                       (d)  $\frac{29}{-42}$
  
4. Which of the rational numbers  $\frac{-5}{16}$ ,  $\frac{-13}{24}$ ,  $\frac{3}{-4}$ ,  $\frac{7}{-12}$  is the smallest?  
(a)  $\frac{-5}{16}$       (b)  $\frac{-13}{24}$                       (c)  $\frac{3}{-4}$                       (d)  $\frac{7}{-12}$
  
5. Simplify:  $\frac{2}{3} + \frac{-4}{5} + \frac{7}{15} + \frac{-11}{20}$   
(a)  $\frac{-1}{5}$       (b)  $\frac{-13}{60}$                       (c)  $\frac{-4}{15}$                       (d)  $\frac{-7}{30}$
  
6. Rational number  $\frac{3}{40}$  is equal to:  
(a) 0.75      (b) 0.12                      (c) 0.012                      (d) 0.075
  
7. A rational number between 3 and 4 is:  
(a)  $\frac{3}{2}$       (b)  $\frac{4}{3}$                       (c)  $\frac{7}{2}$                       (d)  $\frac{7}{4}$
  
8. A rational number between  $\frac{3}{5}$  and  $\frac{4}{5}$  is:  
(a)  $\frac{7}{5}$       (b)  $\frac{7}{10}$                       (c)  $\frac{3}{10}$                       (d)  $\frac{4}{10}$
  
9. A rational number between  $\frac{1}{2}$  and  $\frac{3}{4}$  is:  
(a)  $\frac{2}{5}$       (b)  $\frac{5}{8}$                       (c)  $\frac{4}{3}$                       (d)  $\frac{1}{4}$
  
10. The multiplicative inverse of  $\frac{3}{40}$  is:  
(a) 1      (b) 0                      (c) any number                      (d) none of these

**PRACTICE QUESTIONS**  
**CLASS VIII: CHAPTER - 1**  
**RATIONAL NUMBERS**

1. Find  $\frac{3}{7} + \left(\frac{-6}{11}\right) + \left(\frac{-8}{21}\right) + \frac{5}{22}$
2. Find  $\frac{-4}{5} \times \frac{3}{7} \times \frac{15}{16} \times \left(\frac{-14}{9}\right)$
3. Find using distributive property: (i)  $\left\{\frac{7}{5} \times \left(\frac{-3}{12}\right)\right\} + \left\{\frac{7}{5} \times \frac{5}{12}\right\}$  (ii)  $\left\{\frac{9}{16} \times \frac{4}{12}\right\} + \left\{\frac{9}{16} \times \frac{-3}{9}\right\}$
4. Find  $\frac{2}{5} \times \frac{-3}{7} - \frac{1}{14} - \frac{3}{7} \times \frac{3}{5}$
5. Simplify:  $\frac{-4}{5} \times \frac{3}{7} \times \frac{15}{16} \times \left(\frac{-14}{9}\right)$
6. Multiply  $\frac{6}{13}$  by the reciprocal of  $\frac{-7}{16}$ .
7. What number should be added to  $\frac{7}{12}$  to get  $\frac{4}{15}$  ?
8. What number should be subtracted from  $-\frac{3}{5}$  to get  $-2$ ?
9. Is  $\frac{8}{9}$  the multiplicative reciprocal of  $-1\frac{1}{8}$  ? Why or why not?
10. Is 0.3 the multiplicative reciprocal of  $3\frac{1}{3}$  ? Why or why not?
11. Write any 3 rational numbers between  $-2$  and  $0$ .
12. Find any ten rational numbers between  $-\frac{5}{6}$  and  $\frac{5}{8}$
13. Find three rational numbers between  $\frac{1}{4}$  and  $\frac{1}{2}$
14. Find ten rational numbers between  $\frac{1}{4}$  and  $\frac{1}{2}$
15. Represent these numbers on the number line. (i)  $\frac{7}{4}$  (ii)  $-\frac{5}{6}$  (iii)  $\frac{4}{7}$  (iv)  $\frac{9}{4}$
16. Represent  $\frac{-2}{11}, \frac{-5}{11}, \frac{-9}{11}$  on the number line
17. Find five rational numbers between. (i)  $\frac{2}{3}$  and  $\frac{4}{5}$  (ii)  $-\frac{3}{2}$  and  $\frac{5}{3}$  (iii)  $\frac{1}{4}$  and  $\frac{1}{2}$
18. Write five rational numbers greater than  $-2$
19. Find ten rational numbers between  $\frac{3}{5}$  and  $\frac{3}{4}$ .
20. Write.
  - (i) The rational number that does not have a reciprocal.
  - (ii) The rational numbers that are equal to their reciprocals.
  - (iii) The rational number that is equal to its negative.

**ASSIGNMENT QUESTIONS**  
**CLASS VIII: CHAPTER - 1**  
**RATIONAL NUMBERS**

1. Simplify: (i)  $\frac{-2}{5} - \left(\frac{-3}{10}\right) - \left(\frac{-4}{15}\right)$  (ii)  $\frac{5}{3} - \frac{7}{6} + \left(\frac{-2}{3}\right)$  (iii)  $\frac{-3}{2} + \left(\frac{5}{4} - \frac{7}{4}\right)$
2. Verify that  $(x \times y)^{-1} = x^{-1} \times y^{-1}$  when  $x = \frac{-2}{3}$  and  $y = \frac{-3}{5}$
3. If you subtract  $\frac{1}{2}$  from a number and multiply the result by  $\frac{1}{2}$ , you get  $\frac{1}{8}$ . What is the number?
4. Three consecutive integers are such that when they are taken in increasing order and multiplied by 2, 3, and 4 respectively, they add up to 74. Find these numbers.
5. Represent the following rational numbers on the number line  
(a)  $-\frac{1}{4}$  (b)  $-1\frac{1}{5}$  (c)  $-3\frac{8}{5}$
6. Represent the following rational numbers on the number line  
(a)  $-\frac{7}{10}$  (b)  $-5\frac{3}{5}$ .
7. Find two rational numbers between (i)  $-2$  and  $2$ . (ii)  $-1$  and  $0$ .
8. Insert six rational numbers between (i)  $-\frac{1}{3}$  and  $-\frac{2}{3}$  (ii)  $\frac{1}{4}$  and  $\frac{1}{2}$ .
9. Arrange the following numbers in ascending order:  $\frac{4}{-9}$ ,  $\frac{-5}{12}$ ,  $\frac{7}{-18}$ ,  $\frac{-2}{3}$
10. Arrange the following numbers in descending order:  $-\frac{5}{6}$ ,  $-\frac{7}{12}$ ,  $\frac{-13}{28}$ ,  $\frac{23}{-24}$
11. Represent  $4\frac{2}{3}$  on the number line.
12. What number should be added to  $\frac{-7}{8}$  to get  $\frac{4}{9}$ ?
13. The sum of two rational numbers is  $\frac{-1}{2}$ . If one of the numbers is  $\frac{5}{6}$ , find the other.
14. What number should be subtracted from  $\frac{-2}{3}$  to get  $\frac{-1}{2}$ ?
15. Divide the sum of  $\frac{13}{5}$  and  $\frac{-12}{7}$  by the product of  $\frac{-31}{7}$  and  $\frac{-1}{2}$ .
16. The product of two rational numbers is  $\frac{-16}{9}$ . If one of the numbers is  $\frac{-4}{3}$ , find the other.
17. Find three rational numbers between 4 and 5.
18. Find three rational numbers between  $\frac{2}{3}$  and  $\frac{3}{4}$ .
19. Find the HCF of  $\frac{9}{10}$ ,  $\frac{12}{25}$ ,  $\frac{18}{35}$ ,  $\frac{21}{40}$ .

20. After reading  $\frac{7}{9}$  of a book, 40 pages are left. How many pages are there in the book?
21. A drum full of rice weights 4016 kg. If the empty drum weights 1334 kg, find the weight of rice in the drum.
22. Raju earns Rs16000/month. He spends  $\frac{1}{4}$  of his income on food;  $\frac{3}{10}$  of the remainder on house rent and  $\frac{5}{21}$  of the remainder on education of children. How much money is still left with him?
23. Divide the sum of  $2\frac{1}{4}$  and  $5\frac{1}{5}$  by the product of  $2\frac{1}{4}$  and  $\frac{2}{3}$
24. Divide the difference of  $\frac{12}{7}$  and  $\frac{13}{4}$  by the product of  $\frac{4}{5}$  and  $\frac{25}{2}$ .
25. A tin holds  $16\frac{1}{2}$  litres of oil. How many such tins will be required to hold  $313\frac{1}{2}$  litres of oil?
26. Salma bought  $2\frac{1}{2}$  kg onions at Rs. 12 per Kg. and  $1\frac{3}{8}$  Kg. tomatoes at Rs.  $16\frac{8}{11}$  per Kg. How much money did she give to the shopkeeper?
27. A designer needs  $\frac{3}{5}$  th of a metre of cloth to make a fancy dress for children taking part in a dance performance. If 200 children are taking part, how much cloth will the designer need?
28. Find a rational number between  $\frac{1}{2}$  and  $\frac{1}{4}$  such that its denominator is 8.
29. Which number should be subtracted from  $\frac{11}{12}$  so that we obtain  $\frac{-3}{4}$ ?
30. What number should be added to  $\frac{15}{16}$  so that we get the rational number  $\frac{77}{48}$ .
- .....



**MCQ WORKSHEET-I**  
**CLASS VIII: CHAPTER - 2**  
**LINEAR EQUATION IN ONE VARIABLE**

1. The solution of  $2x - 3 = 7$  is  
(a) 2      (b) -2      (c) 5      (d) -5
  2. Which of the following is not a linear equation  
(a)  $2x + 5 = 1$       (b)  $x - 1 = 0$       (c)  $y + 1 = 0$       (d)  $5x + 3$
  3. Solve  $2y + 9 = 4$   
(a) 2      (b) -2      (c) 5      (d) none of these
  4. Solve :  $\frac{x}{3} + \frac{5}{2} = \frac{-3}{2}$   
(a) 12      (b) -12      (c) 15      (d) none of these
  5. Solve:  $\frac{15}{4} - 7x = 9$   
(a)  $\frac{3}{4}$       (b)  $-\frac{3}{4}$       (c) 1      (d) none of these
  6. Solve:  $x - 2 = 7$   
(a) 5      (b) -9      (c) 5      (d) 9
  7. Solve:  $y + 3 = 10$   
(a) 7      (b) -7      (c) 13      (d) -13
  8. Solve:  $6 = z + 2$   
(a) 4      (b) -4      (c) 8      (d) -8
  9. Solve:  $6x = 12$   
(a) 2      (b) -2      (c) 3      (d) none of these
  10. Solve:  $\frac{x}{5} = 10$   
(a) 15      (b) 50      (c) -50      (d) none of these
  11. Solve:  $\frac{2x}{3} = 18$   
(a) 9      (b) 27      (c) -9      (d) none of these
  12. The present age of Sahil's mother is three times the present age of Sahil. After 5 years their ages will add to 66 years. Find the present ages of Sahil.  
(a) 12      (b) 14      (c) 16      (d) 20
- .....

**MCQ WORKSHEET-II**  
**CLASS VIII: CHAPTER - 2**  
**LINEAR EQUATION IN ONE VARIABLE**

1. Solve:  $7x - 9 = 12$   
(a) 2      (b) -2      (c) 3      (d) none of these
2. Find the solution of  $2x + 3 = 7$   
(a) 2      (b) -2      (c) 3      (d) none of these
3. Solve:  $8x = 20 + 3x$   
(a) 4      (b) -4      (c) 2      (d) none of these
4. Solve:  $\frac{2}{3}x + 1 = \frac{7}{3}$   
(a) 2      (b) -2      (c) 3      (d) none of these
5. Solve:  $\frac{x}{4} + \frac{x}{6} = x - 7$   
(a) 12      (b) -12      (c) 3      (d) none of these
6. Find the solution of  $\frac{3x+5}{2x+1} = \frac{1}{3}$   
(a) 2      (b) -2      (c) 3      (d) none of these
7. Find the solution of  $\frac{x+6}{4} + \frac{x-3}{5} = \frac{5x-4}{8}$   
(a) 8      (b) -8      (c) 4      (d) none of these
8. Solve:  $8x + 3 = 27$   
(a) 3      (b) -3      (c) 2      (d) none of these
9. Solve:  $5x - 7 = 2x + 8$   
(a) 5      (b) -9      (c) 5      (d) 9
10. The perimeter of a rectangle is 13 cm and its width is  $2\frac{3}{4}$  cm. Find its length in cm.  
(a)  $3\frac{3}{4}$       (b)  $-3\frac{3}{4}$       (c)  $2\frac{3}{4}$       (d) none of these
11. Bansi has 3 times as many two-rupee coins as he has five-rupee coins. If he has in all a sum of Rs 77, how many coins of each denomination does he have?  
(a) 7, 21      (b) 3, 9      (c) 6, 18      (d) 5, 15
12. The sum of three consecutive multiples of 11 is 363. Find these multiples.  
(a) 117, 121, 125      (b) 110, 121, 132      (c) 110, 99, 154      (d) 154, 88, 121

**MCQ WORKSHEET-III**  
**CLASS VIII: CHAPTER - 2**  
**LINEAR EQUATION IN ONE VARIABLE**

1. The difference between two whole numbers is 66. The ratio of the two numbers is 2 : 5. What are the two numbers?  
(a) 110, 44      (b) 120, 54      (c) 140, 74      (d) none of these
  2. Sum of two numbers is 95. If one exceeds the other by 15, find the numbers.  
(a) 55, 35      (b) 50, 45      (c) 40, 25      (d) none of these
  3. Two numbers are in the ratio 5:3. If they differ by 18, what are the numbers?  
(a) 45, 27      (b) 50, 32      (c) 40, 22      (d) none of these
  4. Three consecutive integers add up to 51. What are these integers?  
(a) 117, 121, 125      (b) 110, 121, 132      (c) 110, 99, 154      (d) none of these
  5. The sum of three consecutive multiples of 8 is 888. Find the multiples.  
(a) 120, 136, 400      (b) 110, 121, 132      (c) 110, 99, 154      (d) none of these
  6. Solve:  $2x - 3 = x + 2$   
(a) 5      (b) -9      (c) 5      (d) 9
  7. Solve:  $3x = 2x + 18$   
(a) 18      (b) -18      (c) 14      (d) none of these
  8. Solve:  $5t - 3 = 3t - 5$   
(a) 1      (b) -1      (c) 2      (d) none of these
  9. Solve:  $5x + 9 = 5 + 3x$   
(a) 2      (b) -2      (c) 3      (d) none of these
  10. Solve:  $4z + 3 = 6 + 2z$   
(a)  $\frac{3}{2}$       (b)  $-\frac{3}{2}$       (c) 2      (d) none of these
  11. Solve:  $2x - 1 = 14 - x$   
(a) 5      (b) -9      (c) 5      (d) 9
  12. Solve:  $8x + 4 = 3(x - 1) + 7$   
(a) 1      (b) -1      (c) 0      (d) none of these
- .....

**PRACTICE QUESTIONS**  
**CLASS VIII: CHAPTER - 2**  
**LINEAR EQUATION IN ONE VARIABLE**

1. Find the solution of  $\frac{3x+5}{2x+1} = \frac{1}{3}$
2. Find the solution of  $\frac{x+6}{4} + \frac{x-3}{5} = \frac{5x-4}{8}$
3. Solve:  $\frac{x}{4} + \frac{x}{6} = x - 7$
4. Solve:  $\frac{2}{3}x + 1 = \frac{7}{3}$
5. Solve:  $\frac{x}{3} + \frac{5}{2} = \frac{-3}{2}$
6. Solve:  $\frac{15}{4} - 7x = 9$
7. Solve:  $x = \frac{4}{5}(x+10)$
8. Solve:  $\frac{2x}{3} + 1 = \frac{7x}{15} + 3$
9. Solve:  $2y + \frac{5}{3} = \frac{26}{3} - y$
10. Solve:  $3m - 5m - \frac{8}{5}$
11. Solve:  $5x + \frac{7}{2} = \frac{3}{2}x - 14$
12. The perimeter of a rectangular swimming pool is 154 m. Its length is 2 m more than twice its breadth. What are the length and the breadth of the pool?
13. The base of an isosceles triangle is  $\frac{4}{3}$  cm. The perimeter of the triangle is  $4\frac{2}{15}$  cm.  
What is the length of either of the remaining equal sides?
14. Sum of two numbers is 95. If one exceeds the other by 15, find the numbers.
15. Two numbers are in the ratio 5:3. If they differ by 18, what are the numbers?
16. Three consecutive integers add up to 51. What are these integers?
17. The sum of three consecutive multiples of 8 is 888. Find the multiples.
18. Three consecutive integers are such that when they are taken in increasing order and multiplied by 2, 3 and 4 respectively, they add up to 74. Find these numbers.
19. The ages of Rahul and Haroon are in the ratio 5:7. Four years later the sum of their ages will be 56 years. What are their present ages?
20. The number of boys and girls in a class are in the ratio 7:5. The number of boys is 8 more than the number of girls. What is the total class strength?

21. Fifteen years from now Ravi's age will be four times his present age. What is Ravi's present age?
22. A rational number is such that when you multiply it by  $\frac{5}{2}$  and add  $\frac{2}{3}$  to the product, you get  $-\frac{7}{12}$ . What is the number?
23. Lakshmi is a cashier in a bank. She has currency notes of denominations Rs 100, Rs 50 and Rs 10, respectively. The ratio of the number of these notes is 2:3:5. The total cash with Lakshmi is Rs 4,00,000. How many notes of each denomination does she have?
24. I have a total of Rs 300 in coins of denomination Re 1, Rs 2 and Rs 5. The number of Rs 2 coins is 3 times the number of Rs 5 coins. The total number of coins is 160. How many coins of each denomination are with me?
25. The organisers of an essay competition decide that a winner in the competition gets a prize of Rs 100 and a participant who does not win gets a prize of Rs 25. The total prize money distributed is Rs 3,000. Find the number of winners, if the total number of participants is 63.
26. Deveshi has a total of Rs 590 as currency notes in the denominations of Rs 50, Rs 20 and Rs 10. The ratio of the number of Rs 50 notes and Rs 20 notes is 3:5. If she has a total of 25 notes, how many notes of each denomination she has?

27. Solve:  $\frac{6x+1}{3} + 1 = \frac{x-3}{6}$

28. Solve:  $5x - 2(2x - 7) = 2(3x - 1) + \frac{7}{2}$

29. Solve:  $\frac{3x-2}{4} - \frac{2x+3}{3} = \frac{2}{3} - x$

30. Solve:  $\frac{3x+2}{7} + \frac{4(x+1)}{5} = \frac{2}{3}(2x+1)$

31. Solve:  $x - \frac{x-1}{2} = 1 - \frac{x-2}{3}$

32. Solve:  $\frac{x}{2} - \frac{3x}{4} + \frac{5x}{6} = 21$

33. Solve:  $x + 7 - \frac{8x}{3} = \frac{17}{6} - \frac{5x}{2}$

34. Solve:  $\frac{3x+4}{2-6x} = \frac{-2}{5}$

35. Solve:  $\frac{7x+4}{x+2} = \frac{-4}{3}$

Assignment Questions  
CLASS VIII: CHAPTER - 2  
LINEAR EQUATION IN ONE VARIABLE

1. A train is moving at the speed of  $x$  km/hour. What distance will it cover in 15 hours if it stops for 1 hour at two stations.
2. 48 sweets are to be distributed among three friends  $A$ ,  $B$  and  $C$  in such a way that  $B$  gets 5 sweets more than  $A$  and  $C$  gets 7 sweets more than  $A$ . Form an equation.
3. I guessed a number ( $x$ ) then added 10 to it. Give the expression for double of it.
4. Find  $x$  if  $2x + 5 = x + 25$ .
5. Ratio of three angles of a triangle is  $1 : 2 : 3$ . Find the angles.
6. Perimeter of the top of a table in the conference hall is 32cm. If the length of the table is 3 times its breadth, how long is the table?
7. Preeti has three more dolls than Renu. If there are 11 dolls in all, how many dolls does each have.
8. Ankit covered  $\frac{1}{2}$  of the distance by metro train,  $\frac{1}{3}$  of the distance by bus and rest of 6 km by car for moving from Dwarka to South Extension. Find the total distance covered?
9. Sum of two numbers is 30. If one number is twice the other, form an equation for finding the numbers.
10. If  $3(x + 4) = x + 38$  find  $x$ .
11. Ratio of three sides of a triangle are  $1 : 3 : 5$  and perimeter of the triangle is 270m. Find the sides.
12. Two numbers are in the ratio 4:7. If the sum of numbers is 143, find the numbers.
13. Sides of a rectangle are in the ratio 14:3. If the perimeter of the rectangle is 170 cms, find the length and breadth.
14. Find three consecutive odd numbers whose sum is 147.
15. If father is twice as old as his son and also 29 years older than his son. What is the age of father?
16. If you subtract  $\frac{1}{2}$  from a number and multiply the result by  $\frac{1}{2}$ , you get  $\frac{1}{8}$ . What is the number?
17. The perimeter of a rectangular swimming pool is 154 metres. Its length is 2 m more than twice its breadth. What are the length and breadth of the pool
18. The base of an isosceles triangle is  $\frac{4}{3}$  cms. The Perimeter of the triangle is  $4\frac{2}{15}$  cm. Find the length of other two sides of the triangle
19. Sum of two numbers is 95. If one exceeds the other by 15 find the numbers
20. Two numbers are in the ration 5:3. If they differ by 18, find these numbers

21. Three consecutive integers add up to 51. What are these integers?
22. The sum of three consecutive multiples of 8 is 888. Find the multiple
23. Three consecutive integers are as such when they are taken in increasing order and multiplied by 2, 3, and 4 respectively, they add up to 74. Find these numbers
24. The ages of Rahul and Haroon are in the ratio of 5:7. Four years from now sum of their ages will be 56 years. Find their present age.
25. Baichung's father is 26 years younger than Baichung's grandfather and 29 years older than Baichung. The sum of their ages is 135. Find their ages
26. Lakshmi is a cashier in a bank. She has notes of denominations of Rs.100, 50 and 10 respectively. The ratio of number of these notes is 2:3:5 respectively. The total cash with Lakshmi is 4,00,000. How many notes of each denomination does she have?
27. Lakshmi is a cashier in a bank. She has notes of denominations of Rs.100, 50 and 10 respectively. The ratio of number of these notes is 2:3:5 respectively. The total cash with Lakshmi is 4,00,000. How many notes of each denomination does she have?
28. The organizers in an essay competition decide that winner will get a prize of Rs. 100 and a participation who doesn't win gets a prize of Rs. 25. The total prize money distributed is Rs. 3,000. Find the number of winners if the total number of participants is 63.
29. Sum of the digits of a two digit number is 9. When we interchange the digits the new number is 27 greater than the earlier number. Find the number
30. One of the digits of a two digit number is three times the other digit. If you interchange the digits and add the resulting number to original number you get 88 as final result. Find the numbers.
31. Sahoo's mother's present age is six times Sahoo's present age. Five year from now Sahoo's age will be one-third of his mother's age. Find their current age
32. Half of a herd of deer are grazing in the field and three fourths of the remaining are playing nearby. The rest 9 are drinking water from the pond. Find the total number of deer in the herd
33. A man's age is three times his son's age. Ten years ago his age was five times his son's age. Find their current age
34. If in a rational number denominator is greater than numerator by 8. If you increase the numerator by 17 and decrease the denominator by 1, you get  $\frac{3}{2}$  as result. Find the number
35. The perimeter of a rectangular swimming pool is 154 m. Its length is 2m more than twice its breadth. What are the length and breadth of the pool?
36. Two numbers are in the ratio 8:3. If sum of the numbers is 143, find the numbers
37. Four-fifths of a number is 10 more than two-thirds of the number. Find the number
38. If 10 be added to four times a certain number, the result is 5 less than five times the number. Find the number

39. The width of a rectangle is two-thirds its length. If the perimeter is 180m, find the dimensions of the rectangle
40. Rakhi's mother is four times as old as Rakhi. After 5years, her mother will be three times as she will be then. Find their present ages
41. The length of a rectangle exceeds its breadth by 7cm. If the length is decreased by 4cm and the breadth is increased by 3cm, the area of the new rectangle is the same as the area of original rectangle. Find the length and breadth of the original rectangle
42. The difference between ages of two cousins is 10years. 15yearsago, if the elder one was twice as old as the younger one, find their present ages.
43. Find three consecutive even numbers whose sum is 234
44. Twenty four is divided into two parts such that 7times the first part added to 5times the second part makes 146. Find each part
45. Three numbers are in ratio 4:5:6. If the sum of the largest and the smallest equals the sum of the third and 55, find the numbers
46. The altitude of a triangle is five-thirds the length of its corresponding base. If the altitude be increased by 4 cm , and the base decreased by 2cm, the area of the triangle remains the same. Find the base and altitude of the triangle
47. A streamer goes downstream from point A to B in 9hrs. From B to A, upstream, it takes 10h. If the speed of the stream is 1km/hr, what will be the speed of streamer in still water? Also find distance between the points A and B.
48. Divide 150 into three parts, such that the second number is five-sixths the first and the third number is four-fifths the second
49. The ages of Sonu and Monu are in the ratio 5:7. If Sonu were 9yearsolder and Monu 9years younger, the age of Sonu would have been twice the age of Monu. Find their ages
50. Two years ago, Dalip was three times as old as his son and two years hence, twice his age will be equal to five times that of his son. Find their present ages. Check your solution
51. The distance between two stations is 425km. Two trains start simultaneously from these stations on parallel tracks to cross each other. The speed of one of them is greater than that of the other by 5km/h. If the distance between the two trains after 3h of their start is 20km, find the speed of each train. Check your solution
52. The length of a rectangle exceeds its breadth by 9cm. If the length and breadth are each increased by 3cm, the area of the new rectangle will be 84cm<sup>2</sup>more than that of the given rectangle. Find the length and breadth of the given rectangle. Check your solution.
53. The digit in the tens place of a two-digit number is three times that in the units place. If the digits are reversed, the new number will be 36 less than the original number. Find the original number
54. A motor boat covers a certain distance downstream in a river in 5 hours. It covers the same distance upstream in 6 hours. The speed of water is 2 km/hr . Find the speed of the boat in still water.



55. Three prizes are to be distributed in a quiz contest. The value of the second prize is five sixths the value of the first prize and the value of the third prize is four – fifths that of the second prize. If the total value of three prizes is Rs. 150, find the value of each prize.
56. Each side of a triangle is increased by 10 cm. If the ratio of the perimeters of the new triangle and the given triangle is 5 : 4, find the perimeter of the given triangle
57. The difference between two positive integers is 36. The quotient, when one integer is divided by the other is 4. Find the two integers.
58. Amina thinks of a number and subtracts  $\frac{5}{2}$  from it. She multiplies the result by 8. The final result is 3 times her original number. Find the number
59. A positive number is 5 times another number. If 21 is added to both the numbers then one of the new numbers becomes twice of another new numbers. Find the original numbers.
60. Sum of the digits of a two digit number is 9. When we interchange the digits the new number is 27 greater than the earlier number. Find the number.
- .....

**MCQ WORKSHEET-I**  
**CLASS VIII: CHAPTER - 3**  
**UNDERSTANDING QUADRILATERALS**

1. A simple closed curve made up of only \_\_\_\_\_ is called a polygon .  
(a) curves                      (b) line segments                      (c) lines                      (d) closed curves
  2. A polygon with minimum number of sides is  
(a) Pentagon                      (b) Square                      (c) triangle                      (d) angle
  3. Polygons that have no portions of their diagonals in their exteriors are called  
(a) Squares                      (b) triangles                      (c) convex                      (d) concave
  4. Polygons that have any portions of their diagonals in their exteriors are called  
(a) Squares                      (b) triangles                      (c) convex                      (d) concave
  5. All the sides of a regular polygon are \_\_\_\_\_.  
(a) Parallel                      (b) equal in length                      (c) not parallel                      (d) not equal
  6. All the angles of a regular polygon are of \_\_\_\_\_.  
(a)  $90^\circ$                       (b)  $60^\circ$                       (c) equal measure (d) equal length
  7. Sum of all interior angles of a polygon with (n) sides is given by  
(a)  $(n - 2) \times 180^\circ$                       (b)  $n - 2 \times 180^\circ$                       (c)  $(n + 2) \times 180^\circ$                       (d)  $n + 2 \times 180^\circ$
  8. Maximum number of right angles in a right angled triangle are  
(a) 2                      (b) 1                      (c) 3                      (d) 0
  9. Sum of all interior angles of a parallelogram is  
(a)  $180^\circ$                       (b)  $360^\circ$                       (c)  $540^\circ$                       (d)  $240^\circ$
  10. The angle sum of all interior angles of a convex polygon of sides 7 is  
(a)  $180^\circ$                       (b)  $540^\circ$                       (c)  $630^\circ$                       (d)  $900^\circ$
  11. Each exterior angle of a regular hexagon is of measure  
(a)  $120^\circ$                       (b)  $80^\circ$                       (c)  $100^\circ$                       (d)  $60^\circ$
  12. The number of sides in a regular polygon is 15 , then measure of each exterior angle is  
(a)  $24^\circ$                       (b)  $36^\circ$                       (c)  $20^\circ$                       (d)  $18^\circ$
  13. How many diagonals does have in a convex quadrilateral?  
(a) 2                      (b) 1                      (c) 3                      (d) none of these
  14. How many diagonals does have in a regular hexagon?  
(a) 2                      (b) 1                      (c) 3                      (d) none of these
  15. How many diagonals does have in a traingle?  
(a) 2                      (b) 1                      (c) 0                      (d) none of these
- .....

**MCQ WORKSHEET-II**  
**CLASS VIII: CHAPTER - 3**  
**UNDERSTANDING QUADRILATERALS**

1. The measure of each interior angle of a regular polygon is  $140^\circ$ , then number of sides that regular polygon has \_\_\_\_\_

- (a) 15                      (b) 12                      (c) 9                      (d) 10

2. Which of the following polygons is convex polygon ?



3. Which of the following is concave polygon?



4. The value of (x) in the following figure is

- (a)  $120^\circ$                       (b)  $80^\circ$   
 (c)  $100^\circ$                       (d)  $60^\circ$

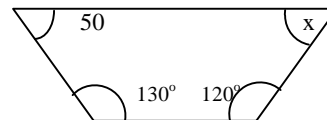

5. A quadrilateral which has 2 pairs of equal adjacent sides but unequal opposite sides is called \_\_\_\_\_.

- (a) parallelogram      (b) rhombus      (c) kite      (d) square

6. The value of x in the following figure is

- (a)  $100^\circ$                       (b)  $90^\circ$   
 (c)  $108^\circ$                       (d)  $120^\circ$

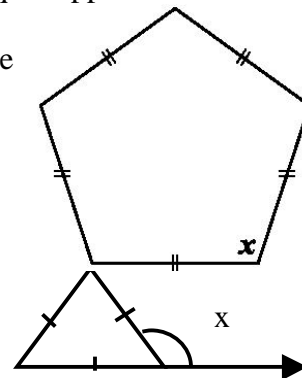

7. The value of x in the following figure is

- (a)  $120^\circ$                       (b)  $180^\circ$                       (c)  $60^\circ$                       (d)  $100^\circ$

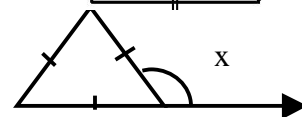

8. A parallelogram each of whose angles measures  $90^\circ$  is \_\_\_\_\_.

- (a) rectangle                      (b) rhombus                      (c) kite                      (d) trapezium

9. A parallelogram whose all sides are equal is called

- (a) square                      (b) rhombus                      (c) rectangle                      (d) trapezium

10. The diagonals of a rhombus bisect each other at \_\_\_\_\_ angles.

- (a) acute                      (b) right                      (c) obtuse                      (d) reflex

11. Diagonals of a rectangle:

- (a) equal to each other                      (b) not equal  
 (c) one is double of the other                      (d) none of these

12. The diagonals of a square bisect each other at \_\_\_\_\_ angle.

- (a) acute                      (b) right                      (c) obtuse                      (d) reflex

**MCQ WORKSHEET-III**  
**CLASS VIII: CHAPTER - 3**  
**UNDERSTANDING QUADRILATERALS**

1. The value of  $x$  in the following figure is:  
(a)  $60^\circ$                       (b)  $70^\circ$                       (c)  $180^\circ$                       (d)  $90^\circ$
2. Minimum possible interior angle in a regular polygon is \_\_\_\_\_.  
(a)  $70^\circ$                       (b)  $60^\circ$                       (c)  $90^\circ$                       (d)  $120^\circ$
3. Maximum possible exterior angle in a regular polygon is \_\_\_\_\_.  
(a)  $70^\circ$                       (b)  $60^\circ$                       (c)  $90^\circ$                       (d)  $120^\circ$
4. How many sides does a heptagon have ?  
(a) 2                              (b) 4                              (c) 7                              (d) 5
5. Name the closed figure with 4 sides ?  
(a) Hexagon    (b) Triangle                      (c) Pentagon    (d) Quadrilateral
6. How many diagonals does a regular Hexagon has ?  
(a) 2                              (b) 9                              (c) 3                              (d) 5
7. What is the number of sides in Hexagon ?  
(a) 4                              (b) 7                              (c) 6                              (d) 5
8. What is the sum of the measures of angles of a convex quadrilaterals?  
(a)  $180^\circ$                       (b)  $90^\circ$                       (c)  $360^\circ$                       (d)  $45^\circ$
9. If the three angles of a quadrilateral are  $120^\circ$ ,  $130^\circ$ ,  $10^\circ$  then what is the fourth angle ?  
(a)  $30^\circ$                       (b)  $100^\circ$                       (c)  $40^\circ$                       (d)  $90^\circ$
10. The opposite angles of a parallelogram are \_\_\_\_\_.  
(a) Unequal                      (b) equal                      (c) complementary                      (d) supplementary
11. The perimeter of parallelogram PQRS is:  
(a) 12 cm                      (b) 7 cm                      (c) 38 cm                      (d) 19 cm
12. The diagonals of a square are \_\_\_\_\_ each other .  
(a) equal to                      (b) unequal to  
(c) perpendicular bisectors of                      (d) none of these
13. A parallelogram with sides of equal length is called \_\_\_\_\_.  
(a) trapezium                      (b) square                      (c) rectangle                      (d) rhombus
14. How many measurements can determine a quadrilateral uniquely?  
(a) 2                              (b) 3                              (c) 4                              (d) 5
15. Diagonals of a parallelogram \_\_\_\_\_ each other.  
(a) bisect                      (b) equal to                      (c) perpendicular to                      (d) none of these

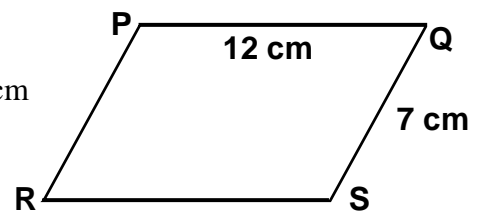

**PRACTICE QUESTIONS**  
**CLASS VIII: CHAPTER - 3**  
**UNDERSTANDING QUADRILATERALS**

- How many diagonals does each of the following have?  
 (a) A convex quadrilateral (b) A regular hexagon (c) A triangle
- What is the sum of the measures of the angles of a convex quadrilateral? Will this property hold if the quadrilateral is not convex? (Make a non-convex quadrilateral and try!)
- What is a regular polygon? State the name of a regular polygon of (i) 3 sides (ii) 4 sides (iii) 6 sides
- Find the angle measure  $x$  in the figures.

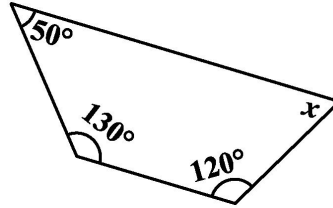

- Find the angle measure  $x$  in the figures.

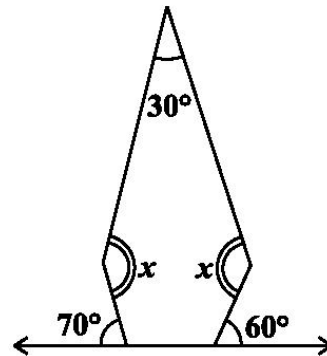
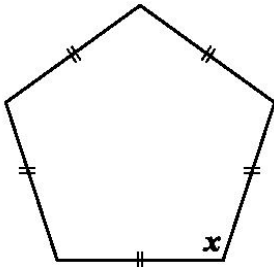

- Find the angle measure  $x$  in the figures.
- Find the angle measure  $x$  in the figures.

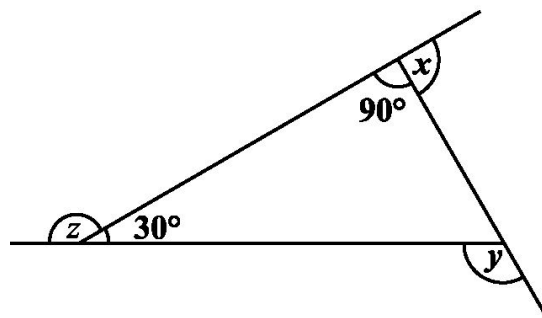
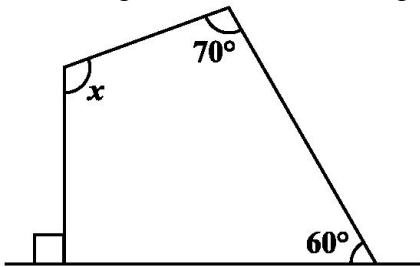

- Find the angle measure  $x$  in the figures.
- Find the angle measure  $x$  in the figures.

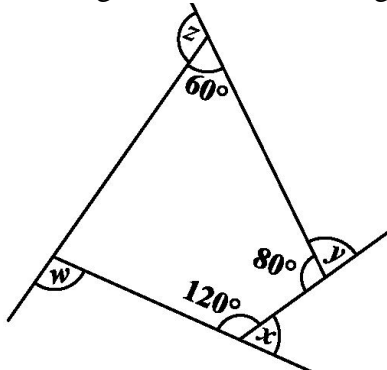

10. Find the angle measure  $x$  in the figure:

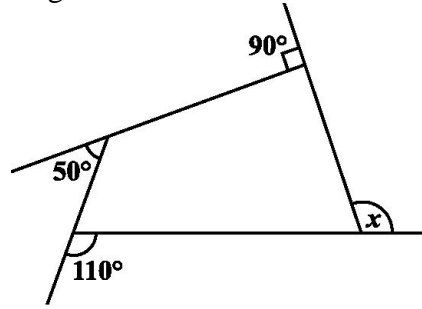

- 11. Find the number of sides of a regular polygon whose each exterior angle has a measure of  $45^\circ$ .
- 12. Find the measure of each exterior angle of a regular polygon of (i) 9 sides (ii) 15 sides
- 13. How many sides does a regular polygon have if the measure of an exterior angle is  $24^\circ$ ?
- 14. How many sides does a regular polygon have if each of its interior angles is  $165^\circ$ ?
- 15. Find the perimeter of the parallelogram PQRS

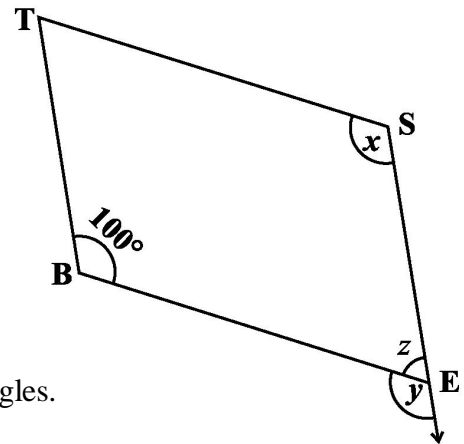
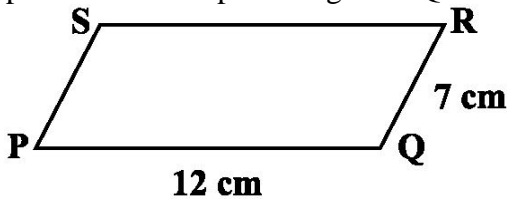

16. In Fig, BEST is a parallelogram. Find the values  $x$ ,  $y$  and  $z$ .

17. In a parallelogram RING, if  $m\angle R = 70^\circ$ , find all the other angles.

18. In Fig HELP is a parallelogram. (Lengths are in cms). Given that  $OE = 4$  and  $HL$  is 5 more than  $PE$ ? Find  $OH$ .

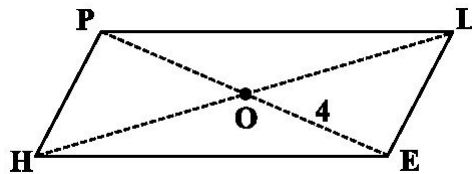

19. RENT is a rectangle. Its diagonals meet at  $O$ . Find  $x$ , if  $OR = 2x + 4$  and  $OT = 3x + 1$ .

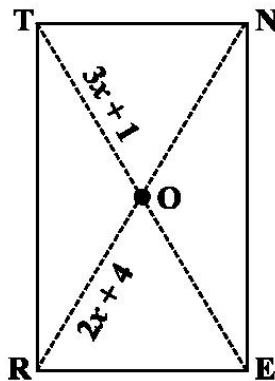

20. Find the number of sides of a regular polygon whose each exterior angle has a measure of  $15^\circ$ .



**ASSIGNMENT QUESTIONS**  
**CLASS VIII: CHAPTER - 3**  
**UNDERSTANDING QUADRILATERALS**

1. Two adjacent angles of a parallelogram are as 2 : 3. Find the measure of each of its angles.
2. ABCD is a parallelogram in which  $\angle A = 75^\circ$ . Find the measure of each of the angles  $\angle B$ ,  $\angle C$  and  $\angle D$ .
3. The external angle of a regular polygon is  $20^\circ$ . How many sides does it have ? What is the measure of each interior angle? What is the total measure of its angles.
4. Is it possible to have a regular polygon with measure of each exterior angle as  $580^\circ$  ? Why? can it be an interior angle of a regular polygon ?
5. Find the measure of each exterior angle of a (i) Regular octagon (ii) Regular Decagon
6. Find the perimeter of a parallelogram with sides 9cm and 5cm.
7. Find the perimeter of a rhombus whose diagonals are 16cm and 12cm
8. The adjacent angles of a parallelogram are in the ratio 5:4 . Find all the angles.
9. If one of the angles of a parallelogram is a right angle, prove that it is a rectangle.
10. If all the angles of a parallelogram are equal. Prove that it is a rectangle.
11. Find the length of the diagonal of a rectangle whose length is 15cm and breadth is 8cm.
12. The measure of two adjacent angles of a quadrilateral are 110 and 50 and the other two acute angles are equal. Find the measure of each angle.
13. The five angles of a pentagon are in the ratio 5 : 6 : 7: 8 :10. Find all the angles.
14. GOAL is a quadrilateral in which  $GO \parallel AL$ . If  $\angle G = \angle O = 40^\circ$ . What are the measures of  $\angle A$  and  $\angle L$ .
15. ABCD is a rhombus whose diagonals AC and BD intersect at a point O. If side AB = 10cm and diagonal BD = 16 cm, find the length of diagonal AC.
16. One of the diagonals of a rhombus is equal to one of its sides. Find the angles of the rhombus.
17. The diagonals of a rhombus ABCD intersect at O. If  $\angle ADC = 120^\circ$  and  $OD = 6$  cm, find (i)  $\angle OAD$  (ii) side AB (iii) perimeter of the rhombus ABCD.
18. ABCD is a trapezium where AB parallel to CD. measure of  $\angle A = \angle B = 45^\circ$ . Prove that  $AD=BC$ .
19. Three angles of a quadrilateral are in the ratio 3:4:5. The difference of the least and the greatest of these angles is 45. Find all the four angles of the quadrilateral.

20. In the below figure, ABCD is a quadrilateral. Find  $x$ .

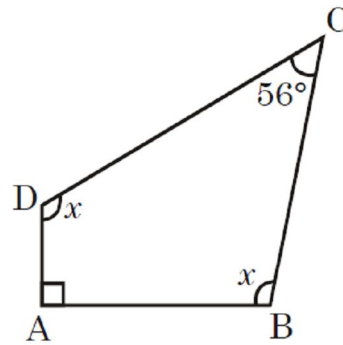
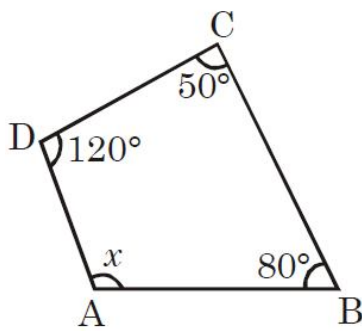

21. In the above right sided figure, ABCD is a quadrilateral. Find  $x$ .

22. In the below figure. Find  $x$ .

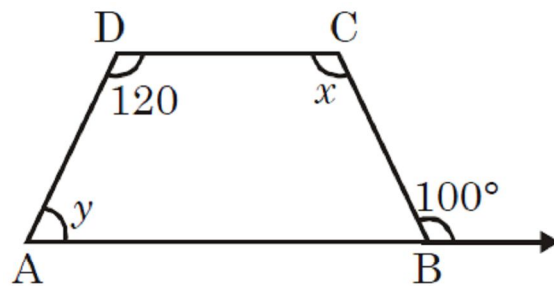
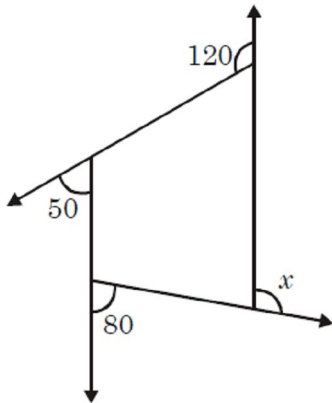

23. In the above right sided figure, ABCD is a quadrilateral in which  $AB \parallel CD$ . Find  $x$  and  $y$ .

24. In the below figure, find  $x$

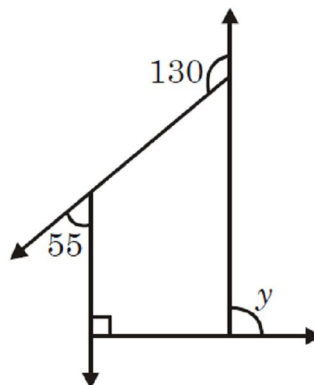
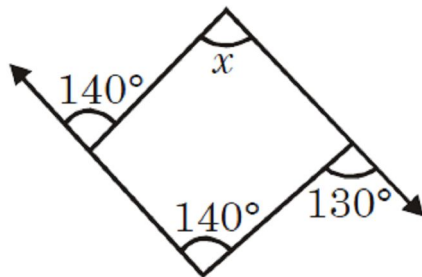

25. In the above right sided figure, find the value of  $y$ .

26. What is the measure of each exterior angle of a regular polygon of 10 sides?

27. How many sides does a regular polygon has if each of its interior angle is  $160^\circ$ ?

28. If the total angle sum of a polygon is  $108^\circ$  then how many sides does polygon has?

29. ABCD is a parallelogram. The perimeter is 144 cm and  $BC = 20$  cm then find  $AB$ .

30. The ratio of two adjacent sides of a parallelogram is 5:4. Its perimeter is 18 cm then, what is the length of the adjacent sides.

31. PQRS is a parallelogram and diagonals PR and SQ bisect at O. If  $PO = 3.5$  cm and  $OQ = 4.1$  cm. What is the length of the diagonals.



32. In the below figure,  $ABCD$  is a parallelogram. What is the value of  $x$ ?

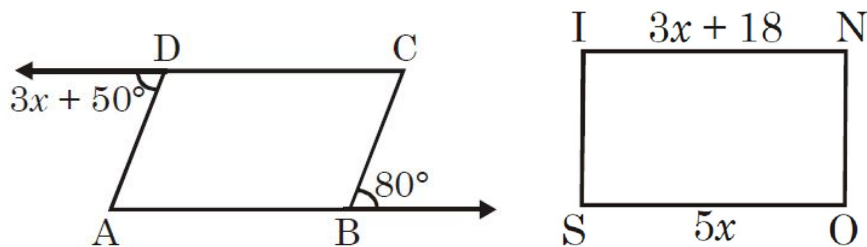

33. In the above right figure,  $SONI$  is a rectangle. What is the length of  $IN$  ?

34. In a parallelogram  $ABCD$ ,  $\angle B = \angle C$ . What is the degree measure of  $\angle B$  and  $\angle C$ .

35. In a parallelogram  $ABCD$  the point of intersection of both diagonals  $AC$  and  $BD$  is  $O$ . If  $AC = 16$  cm and  $BD = 12$  cm then what is  $OA$  and  $OD$ .

36.  $ABCD$  is a rhombus. If  $AB = 4$  cm then what is the perimeter of  $ABCD$ ?

37.  $PQRS$  is a rhombus. If  $PO = 4$  cm and  $OQ = 3$  cm then what is  $PR + SQ$ ?

38.  $PQRS$  is a rhombus with  $PQ = 10$  cm. If  $OQ = 6$  cm then what is the length of the diagonal  $PR$ ?

39. In a rhombus  $RSTU$  if  $\angle R = 120^\circ$ , then what is the measure of  $S$ .

40.  $ABCD$  is a rhombus in which  $AO = 4$ cm and  $OB = 3$  cm. What is the length of the side of the rhombus?

.....

**PRACTICE QUESTIONS**  
**CLASS VIII: CHAPTER - 4**  
**PRACTICAL GEOMETRY**

1. Construct a quadrilateral PQRS where  $PQ = 4$  cm,  $QR = 6$  cm,  $RS = 5$  cm,  $PS = 5.5$  cm and  $PR = 7$  cm.
2. Construct the Quadrilateral ABCD where  $AB = 4.5$  cm,  $BC = 5.5$  cm,  $CD = 4$  cm,  $AD = 6$  cm and  $AC = 7$  cm.
3. Construct Quadrilateral JUMP where  $JU = 3.5$  cm,  $UM = 4$  cm,  $MP = 5$  cm,  $PJ = 4.5$  cm and  $PU = 6.5$  cm
4. Construct Parallelogram MORE where  $OR = 6$  cm,  $RE = 4.5$  cm and  $EO = 7.5$  cm
5. Construct Rhombus BEST where  $BE = 4.5$  cm and  $ET = 6$  cm
6. Construct a quadrilateral ABCD, given that  $BC = 4.5$  cm,  $AD = 5.5$  cm,  $CD = 5$  cm the diagonal  $AC = 5.5$  cm and diagonal  $BD = 7$  cm.
7. Construct quadrilateral LIFT where  $LI = 4$  cm,  $IF = 3$  cm,  $TL = 2.5$  cm,  $LF = 4.5$  cm and  $IT = 4$  cm
8. Construct Rhombus BEND where  $BN = 5.6$  cm and  $DE = 6.5$  cm
9. Construct a quadrilateral MIST where  $MI = 3.5$  cm,  $IS = 6.5$  cm,  $\angle M = 75^\circ$ ,  $\angle I = 105^\circ$  and  $\angle S = 120^\circ$ .
10. Construct Quadrilateral PLAN where  $PL = 4$  cm,  $LA = 6.5$  cm,  $\angle P = 90^\circ$ ,  $\angle A = 110^\circ$  and  $\angle N = 85^\circ$
11. Construct Parallelogram HEAR where  $HE = 5$  cm,  $EA = 6$  cm and  $\angle R = 85^\circ$
12. Construct a quadrilateral ABCD, where  $AB = 4$  cm,  $BC = 5$  cm,  $CD = 6.5$  cm and  $\angle B = 105^\circ$  and  $\angle C = 80^\circ$ .
13. Draw a square of side 4.5 cm.
14. Construct the kite EASY if  $AY = 8$  cm,  $EY = 4$  cm and  $SY = 6$  cm. Which properties of the kite did you use in the process?
15. Construct a rhombus whose diagonals are 5.2 cm and 6.4 cm long.
16. Construct a rectangle with adjacent sides of lengths 5 cm and 4 cm.
17. Construct a square READ with  $RE = 5.1$  cm.
18. Construct a parallelogram OKAY where  $OK = 5.5$  cm and  $KA = 4.2$  cm.
19. Is it possible to construct a rhombus ABCD where  $AC = 6$  cm and  $BD = 7$  cm? Justify your answer.
20. Construct Quadrilateral TRUE where  $TR = 3.5$  cm,  $RU = 3$  cm,  $UE = 4$  cm,  $\angle R = 75^\circ$  and  $\angle U = 120^\circ$

**MCQ WORKSHEET-I**  
**CLASS VIII: CHAPTER - 5**  
**DATA HANDLINGS**

Following bar graph shows marks obtained by a student in 2005–06 and 2006–07 subject wise. Read and answer the questions from Q1 – Q10

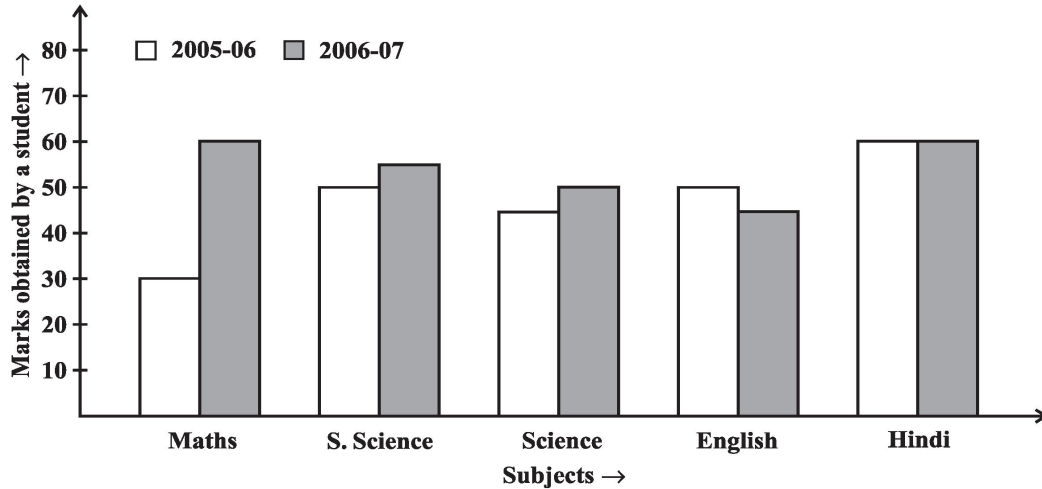

- In which subject has the performance improved the most?  
(a) Maths      (b) Science      (c) S. Science      (d) none of these
- In which subject has the performance deteriorated?  
(a) English      (b) Science      (c) S. Science      (d) none of these
- In which subject is the performance at par?  
(a) Hindi      (b) Science      (c) S. Science      (d) none of these
- Find the marks obtained in Maths by a student in 2005–06 ?  
(a) 30      (b) 40      (c) 50      (d) 60
- Find the marks obtained in Maths by a student in 2006–07 ?  
(a) 30      (b) 40      (c) 50      (d) 60
- Find the marks obtained in Hindi by a student in 2005–06 ?  
(a) 30      (b) 40      (c) 50      (d) 60
- Find the marks obtained in Hindi by a student in 2006–07 ?  
(a) 30      (b) 40      (c) 50      (d) 60
- Find the marks obtained in S. Science by a student in 2005–06 ?  
(a) 30      (b) 40      (c) 50      (d) 60
- Find the total marks obtained by a student in 2005–06?  
(a) 230      (b) 235      (c) 240      (d) none of these
- Find the total marks obtained by a student in 2006–07?  
(a) 230      (b) 270      (c) 240      (d) none of these

**MCQ WORKSHEET-II**  
**CLASS VIII: CHAPTER - 5**  
**DATA HANDLINGS**

Frequency Distribution of Daily Income of 550 workers of a factory is given below. Study the following frequency distribution table and answer the questions from Q1 – Q10.

Class Interval (Daily Income in Rupees)	Frequency (Number of workers)
100-125	45
125-150	25
150-175	55
175-200	125
200-225	140
225-250	55
250-275	35
275-300	50
300-325	20
<b>Total</b>	<b>550</b>

- What is the size of class intervals ?  
(a) 24                      (b) 25                      (c) 26                      (d) 15
- Which class has the highest frequency ?  
(a) 200-225              (b) 300-325              (c) 175-200              (d) 150-175
- Which class has the lowest frequency ?  
(a) 100-125              (b) 300-325              (c) 175-200              (d) 150-175
- What is the upper limit of the class interval 250-275?  
(a) 250                      (b) 275                      (c) 25                      (d) 525
- Which two classes have the same frequency?  
(a) III & IV              (b) I & II                      (c) II & V                      (d) V & VI
- What is the range of the all class interval?  
(a) 250                      (b) 275                      (c) 225                      (d) 525
- What is the lower limit of the class interval 250-275?  
(a) 250                      (b) 275                      (c) 25                      (d) 525
- What is the total number of workers having daily income less than 250?  
(a) 300                      (b) 445                      (c) 305                      (d) 550
- What is the total number of workers having daily income more than 200?  
(a) 300                      (b) 445                      (c) 305                      (d) 550
- What is the total number of workers having daily income between 150–250?  
(a) 300                      (b) 445                      (c) 375                      (d) 550

**MCQ WORKSHEET-III**  
**CLASS VIII: CHAPTER - 5**  
**DATA HANDLINGS**

The number of hours for which students of particular class watched television during holidays is shown through the graph given below. See and answer the questions from Q1 – Q5.

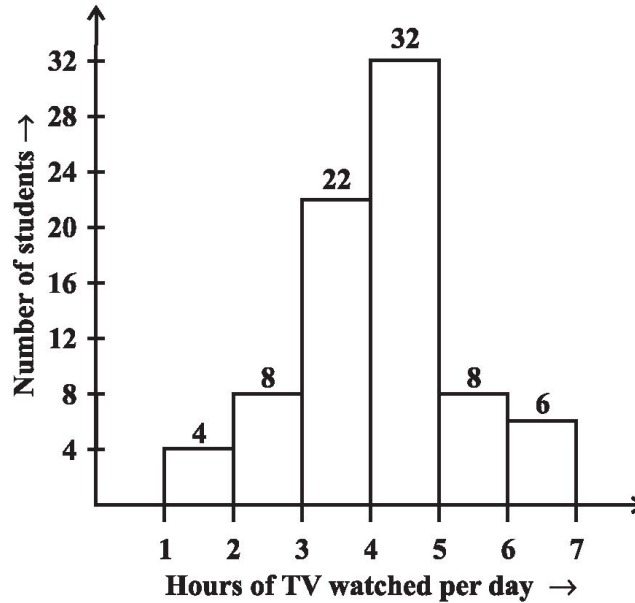

- For how many hours did the maximum number of students watch TV ?  
 (a) 4-5 hrs                      (b) 6-7 hrs                      (c) 3-4 hrs                      (d) 2-3hrs
- How many students watched TV for less than 4 hrs ?  
 (a) 12                              (b) 34                              (c) 4                              (d) 8
- How many students spent more than 5 hrs in TV watching ?  
 (a) 14                              (b) 0                              (c) 6                              (d) 8
- For how many hours did the minimum number of students watch TV ?  
 (a) 2-3 hrs                      (b) 6-7 hrs                      (c) 1-2 hrs                      (d) 3-4hrs
- How many students spent less than 5 hrs in TV watching ?  
 (a) 34                              (b) 32                              (c) 8                              (d) 66

Adjoining pie-chart gives the expenditure (in %age) on various items and savings of a family during a month. Study the given pie-chart and answer the questions from Q6 – Q10.

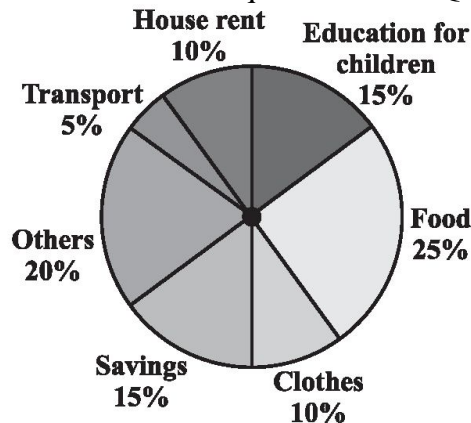

6. On which item the expenditure was maximum ?  
(a) food (b) education (c) others (d) transport
7. On which item the expenditure was minimum ?  
(a) food (b) education (c) others (d) transport
8. Expenditure on which item is equal to total savings of the family ?  
(a) food (b) education (c) others (d) transport
9. Expenditure on which item is equal to total savings of the House Rent?  
(a) food (b) education (c) clothes (d) transport

If the monthly savings of the family is Rs 3000,

10. What is the monthly income of the family?  
(a) 30000 (b) 20000 (c) 25000 (d) 40000
11. What is the monthly expenditure on cloths ?  
(a) 3000 (b) 2000 (c) 2500 (d) 1000
12. What is the monthly expenditure on education for children ?  
(a) 3000 (b) 2000 (c) 2500 (d) 1000
13. What is the monthly expenditure on education for others?  
(a) 3000 (b) 2000 (c) 2500 (d) 4000
14. What is the monthly expenditure on education for Transport?  
(a) 3000 (b) 2000 (c) 2500 (d) 1000
15. What is the monthly expenditure on education for Food?  
(a) 3000 (b) 5000 (c) 2500 (d) 4000

**MCQ WORKSHEET-IV**  
**CLASS VIII: CHAPTER - 5**  
**DATA HANDLINGS**

Cards marked with numbers 1 to 25 are placed in the box and mixed thoroughly. One card is drawn at random from the box. Answer the following questions (Q1-Q10)

1. What is the probability of getting a number 5?  
(a) 1                      (b) 0                      (c)  $\frac{1}{25}$                       (d)  $\frac{1}{5}$
2. What is the probability of getting a number less than 11?  
(a) 1                      (b) 0                      (c)  $\frac{1}{5}$                       (d)  $\frac{2}{5}$
3. What is the probability of getting a number greater than 25?  
(a) 1                      (b) 0                      (c)  $\frac{1}{5}$                       (d)  $\frac{2}{5}$
4. What is the probability of getting a multiple of 5?  
(a) 1                      (b) 0                      (c)  $\frac{1}{25}$                       (d)  $\frac{1}{5}$
5. What is the probability of getting an even number?  
(a) 1                      (b) 0                      (c)  $\frac{12}{25}$                       (d)  $\frac{13}{25}$
6. What is the probability of getting an odd number?  
(a) 1                      (b) 0                      (c)  $\frac{12}{25}$                       (d)  $\frac{13}{25}$
7. What is the probability of getting a prime number?  
(a)  $\frac{8}{25}$                       (b)  $\frac{9}{25}$                       (c)  $\frac{12}{25}$                       (d)  $\frac{13}{25}$
8. What is the probability of getting a number divisible by 3?  
(a)  $\frac{8}{25}$                       (b)  $\frac{9}{25}$                       (c)  $\frac{12}{25}$                       (d)  $\frac{13}{25}$
9. What is the probability of getting a number divisible by 4?  
(a)  $\frac{8}{25}$                       (b)  $\frac{9}{25}$                       (c)  $\frac{6}{25}$                       (d)  $\frac{3}{25}$
10. What is the probability of getting a number divisible by 7?  
(a)  $\frac{8}{25}$                       (b)  $\frac{9}{25}$                       (c)  $\frac{6}{25}$                       (d)  $\frac{3}{25}$

**PRACTICE QUESTIONS**  
**CLASS VIII: CHAPTER - 5**  
**DATA HANDLINGS**

- A group of students were asked to say which animal they would like most to have as a pet. The results are given below:  
 dog, cat, cat, fish, cat, rabbit, dog, cat, rabbit, dog, cat, dog, dog, dog, cat, cow,  
 fish, rabbit, dog, cat, dog, cat, cat, dog, rabbit, cat, fish, dog.  
 Make a frequency distribution table for the same.
- Construct a frequency distribution table for the data on weights (in kg) of 20 students of a class using intervals 30-35, 35-40 and so on.  
 40, 38, 33, 48, 60, 53, 31, 46, 34, 36, 49, 41, 55, 49, 65, 42, 44, 47, 38, 39.
- Observe the histogram and answer the questions given below.

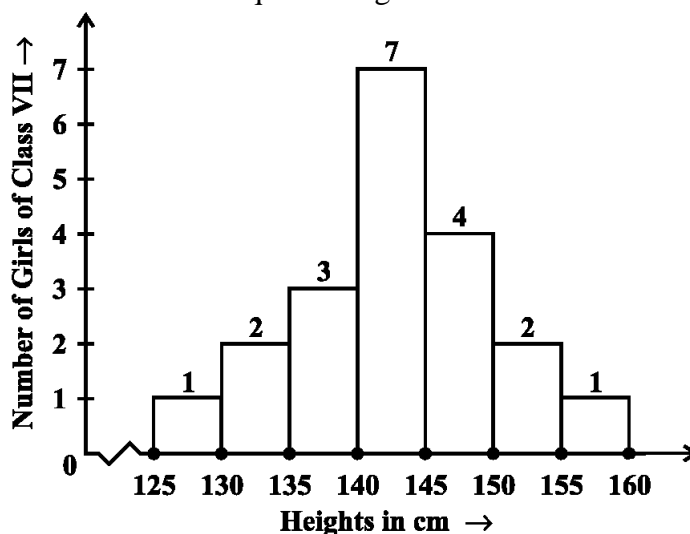

- What information is being given by the histogram?
  - Which group contains maximum girls?
  - How many girls have a height of 145 cms and more?
  - If we divide the girls into the following three categories, how many would there be in each?  
 150 cm and more — Group A  
 140 cm to less than 150 cm — Group B  
 Less than 140 cm — Group C
- The shoppers who come to a departmental store are marked as: man (M), woman (W), boy (B) or girl (G). The following list gives the shoppers who came during the first hour in the morning:  
 W W W G B W W M G G M M W W W W G B M W B G G M W W M M W W  
 W M W B W G M W W W W G W M M W W M W G W M G W M M B G G W  
 Make a frequency distribution table using tally marks. Draw a bar graph to illustrate it.
  - The weekly wages (in Rs) of 30 workers in a factory are.  
 830, 835, 890, 810, 835, 836, 869, 845, 898, 890, 820, 860, 832, 833, 855, 845,  
 804, 808, 812, 840, 885, 835, 835, 836, 878, 840, 868, 890, 806, 840  
 Using tally marks make a frequency table with intervals as 800–810, 810–820 and so on. Draw a histogram for the frequency table and answer the following questions.  
    - Which group has the maximum number of workers?
    - How many workers earn Rs 850 and more?
    - How many workers earn less than Rs 850?



6. Each of the following pie charts gives you a different piece of information about your class. Find the fraction of the circle representing each of these information.

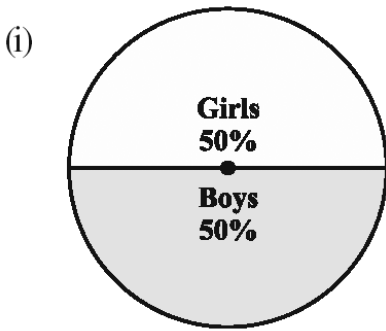

**Girls or Boys**

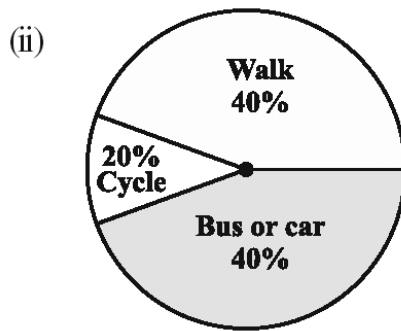

**Transport to school**

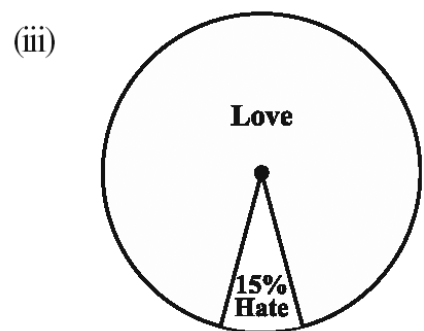

**Love/Hate Mathematics**

7. Below pie chart gives the expenditure (in percentage) on various items and savings of a family during a month.

- (i) On which item, the expenditure was maximum?
- (ii) Expenditure on which item is equal to the total savings of the family?
- (iii) If the monthly savings of the family is Rs 3000, what is the monthly expenditure on clothes?

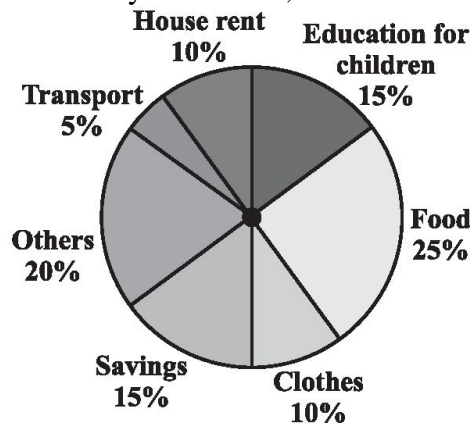



8. On a particular day, the sales (in rupees) of different items of a baker's shop are given below. Draw a pie chart for this data.

ordinary bread	: 320
fruit bread	: 80
cakes and pastries	: 160
biscuits	: 120
others	: 40
<b>Total</b>	<b>: 720</b>

9. Draw a pie chart of the data given below. The time spent by a child during a day.

Sleep	—	8 hours
School	—	6 hours
Home work	—	4 hours
Play	—	4 hours
Others	—	2 hours

Season	No. of votes
Summer 	90
Rainy 	120
Winter 	150

10. A group of 360 people were asked to vote for their favourite season from the three seasons rainy, winter and summer (shown in above fig.). (i) Which season got the most votes? (ii) Find the central angle of each sector. (iii) Draw a pie chart to show this information.

11. The number of students in a hostel, speaking different languages is given below. Display the data in a pie chart.

Language	Hindi	English	Marathi	Tamil	Bengali	Total
No. of Students	40	12	9	7	4	72

12. The adjoining pie chart gives the marks scored in an examination by a student in Hindi, English, Mathematics, Social Science and Science. If the total marks obtained by the students were 540, answer the following questions.

- In which subject did the student score 105 marks?
- How many more marks were obtained by the student in Mathematics than in Hindi?
- Examine whether the sum of the marks obtained in Social Science and Mathematics is more than that in Science and Hindi.

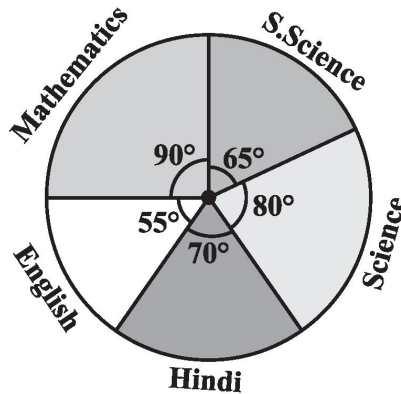

- A box contains 3 blue, 2 white, and 4 red marbles. If a marble is drawn at *random* from the box, what is the probability that it will be (i) white? (ii) blue? (iii) red?
- A die is thrown once. Find the probability of getting (i) a prime number; (ii) a number lying between 2 and 6; (iii) an odd number.
- A bag contains 3 red balls and 5 black balls. A ball is drawn at random from the bag. What is the probability that the ball drawn is (i) red ? (ii) not red?
- A box contains 5 red marbles, 8 white marbles and 4 green marbles. One marble is taken out of the box at random. What is the probability that the marble taken out will be (i) red ? (ii) white ? (iii) not green?
- A bag has 4 red balls and 2 yellow balls. A ball is drawn from the bag without looking into the bag. What is probability of getting a red ball?
- Cards are marked with numbers 1 to 25 are placed in the box and mixed thoroughly. One card is drawn at random from the box. What is the probability that the cards are marked with (i) a prime number (ii) an even number (iii) a number multiple of 5 (iv) a number divisible by 6 and (v) a number 4.
- When a die is thrown, list the outcomes of an event of getting (i) (a) a prime number (b) not a prime number. (ii) (a) a number greater than 5 (b) a number not greater than 5.
- Numbers 1 to 10 are written on ten separate slips (one number on one slip), kept in a box and mixed well. One slip is chosen from the box without looking into it. What is the probability of .
  - getting a number 6?
  - getting a number less than 6?
  - getting a number greater than 6?
  - getting a 1-digit number?

**MCQ WORKSHEET-I**  
**CLASS VIII: CHAPTER - 6**  
**SQUARES AND SQUARE ROOTS**

1. Which is the smallest three-digit perfect square?  
(a) 100                      (b) 101                      (c) 121                      (d) 144
2. Which is the greatest three-digit perfect square?  
(a) 999                      (b) 961                      (c) 962                      (d) 970
3. Which is the greatest 4-digit perfect square?  
(a) 9999                      (b) 9990                      (c) 9800                      (d) 9801
4. Which is the smallest 4-digit perfect square?  
(a) 1024                      (b) 1025                      (c) 1000                      (d) 1016
5. What will be the number of digits in the square root of 25600?  
(a) 3                      (b) 2                      (c) 5                      (d) 4
6. What will be the number of digits in the square root of 1296?  
(a) 2                      (b) 3                      (c) 1                      (d) 4
7. The square root of 12.25 is \_\_\_\_\_ .  
(a) 3.5                      (b) 2.5                      (c) 35                      (d) 25
8. What is the length of the side of a square whose area is  $441 \text{ cm}^2$  ?  
(a) 21                      (b) 22                      (c) 20                      (d) 12
9. In a right angle triangle ABC , right angled at B, AB=6cm, BC=8cm ,then AC= \_\_\_\_ .  
(a) 10                      (b) 12                      (c) 21                      (d) 14
10. Which least number should be subtracted from 629 so as to get a perfect square ?  
(a) 4                      (b) 5                      (c) 6                      (d) 3
11. The square root of 1.21 is  
(a) 1.1                      (b) 11                      (c) 21                      (d) 2.1
12. What is the smallest square number which is divisible by each of the numbers 6,9 and 15 ?  
(a) 900                      (b) 810                      (c) 630                      (d) 720
13. The square of 1.2 is  
(a) 144                      (b) 1.44                      (c) 14.4                      (d) 2.4
14. The square root of 169 is  
(a) -13                      (b) 1.3                      (c) -1.3                      (d)  $\frac{13}{10}$
15. What is the length of the diagonal of a rectangle having dimensions 3cm and 4cm?  
(a) 5                      (b) 7                      (c) 1                      (d) 4

**MCQ WORKSHEET-II**  
**CLASS VIII: CHAPTER - 6**  
**SQUARES AND SQUARE ROOTS**

1. What will be the length of third side of a right angled triangle whose hypotenuse is 5cm and one of the side is 3 cm ?  
(a) 2                                      (b) 3                                      (c) 4                                      (d) 5
2. Which of the following is not a perfect square ?  
(a) 81                                      (b) 18                                      (c) 100                                      (d) 121
3. Which is the smallest square number that is divisible by each of the number 4,9 and 10?  
(a) 900                                      (b) 810                                      (c) 800                                      (d) 920
4. Which of the following is not a square number?  
(a) 4                                      (b) 9                                      (c) 16                                      (d) 24
5. The square of 23 is :  
(a) 529                                      (b) 526                                      (c) 46                                      (d) 429
6. The square of which of the following would be even number?  
(a) 2826                                      (b) 7779                                      (c) 1057                                      (d) 131
7. The square of which of the following would be odd number?  
(a) 431                                      (b) 272                                      (c) 1234                                      (d) 7928
8. Which of the following is a perfect square ?  
(a) 45                                      (b) 81                                      (c) 18                                      (d) 54
9. What will be the “one’s digit” in the square of 1234 ?  
(a) 6                                      (b) 2                                      (c) 8                                      (d) 9
10. What will be the number of zeros in the square of 400 ?  
(a) 5                                      (b) 1                                      (c) 3                                      (d) 4
11. The perfect square number between 30 and 40 is :  
(a) 35                                      (b) 39                                      (c) 36                                      (d) 32
12. Which of the following number would have digit 6 at units place ?  
(a)  $19^2$                                       (b)  $24^2$                                       (c)  $25^2$                                       (d)  $13^2$
13. Which of the following number would have digit 5 at units place :  
(a)  $95^2$                                       (b)  $59^2$                                       (c)  $24^2$                                       (d)  $42^2$
14. Which of the following number would have digit 1 at units place ?  
(a)  $81^2$                                       (b)  $18^2$                                       (c)  $54^2$                                       (d)  $95^2$
15. How many natural numbers lie between  $9^2$  and  $10^2$ ?  
(a) 15                                      (b) 19                                      (c) 18                                      (d) 17

**MCQ WORKSHEET-III**  
**CLASS VIII: CHAPTER - 6**  
**SQUARES AND SQUARE ROOTS**

1. How many non square numbers lie between  $11^2$  and  $12^2$ ?  
(a) 21                      (b) 23                      (c) 22                      (d) 20
  2. 25 can be express as the sum of first \_\_\_\_\_ consecutive odd numbers .  
(a)                      (b) 4                      (c) 6                      (d) 3
  3. How many numbers lie between square of 12 and 13?  
(a) 21                      (b) 23                      (c) 22                      (d) 24
  4. What will be the value of 'x' in Pythagorean triplet (6,8, x)?  
(a) 5                      (b) 7                      (c) 10                      (d) 11
  5. The square of -9 is  
(a) -81                      (b) 81                      (c) 18                      (d) -18
  6. The square root of 6400 is  
(a) 80                      (b) 81                      (c) 32                      (d) 23
  7. By which smallest number 90 must be multiplied so as to make it a perfect square ?  
(a) 10                      (b) 2                      (c) 5                      (d) 3
  8. By which smallest number 48 must be divided so as to make it a perfect square ?  
(a) 2                      (b) 3                      (c) 6                      (d) 4
  9. Which smallest number should be added to 80 so as to make it a perfect square ?  
(a) 2                      (b) 3                      (c) 1                      (d) 4
  10. What could be the possible "one's digit" of the square root of 625?  
(a) 5                      (b) 0                      (c) 4                      (d) 8
  11. The Smallest number by which 12348 must be divided to obtain a perfect square is  
(a) 3                      (b) 5                      (c) 4                      (d) 7
  12.  $\sqrt{0.9} = ?$   
(a) 3                      (b) 0.3                      (c) 0.03                      (d) 0.33
  13.  $\sqrt{1.0816} = ?$   
(a) 1.04                      (b) 1.286                      (c) 0.904                      (d) 1.35
  14.  $\frac{\sqrt{288}}{\sqrt{128}} = ?$   
(a)  $2\frac{1}{14}$                       (b)  $2\frac{3}{14}$                       (c)  $2\frac{5}{14}$                       (d)  $2\frac{9}{14}$
  15.  $\sqrt{0.9} \times \sqrt{1.6} = ?$   
(a) 0.12                      (b) 1.2                      (c) 0.75                      (d) 12
- .....

**PRACTICE QUESTIONS**  
**CLASS VIII: CHAPTER - 6**  
**SQUARES AND SQUARE ROOTS**

1. Find the perfect square numbers between (i) 30 and 40 (ii) 50 and 60
2. Which of  $123^2$ ,  $77^2$ ,  $82^2$ ,  $161^2$ ,  $109^2$  would end with digit 1?
3. Which of the following numbers would have digit 6 at unit place.  
(i)  $19^2$  (ii)  $24^2$  (iii)  $26^2$  (iv)  $36^2$  (v)  $34^2$
4. What will be the “one’s digit” in the square of the following numbers?  
(i) 1234 (ii) 26387 (iii) 52698 (iv) 99880 (v) 21222 (vi) 9106
5. The square of which of the following numbers would be an odd number/an even number? Why?  
(i) 727 (ii) 158 (iii) 269 (iv) 1980
6. What will be the number of zeros in the square of the following numbers?  
(i) 60 (ii) 400
7. How many natural numbers lie between  $9^2$  and  $10^2$ ? Between  $11^2$  and  $12^2$ ?
8. How many non square numbers lie between the following pairs of numbers  
(i)  $100^2$  and  $101^2$  (ii)  $90^2$  and  $91^2$  (iii)  $1000^2$  and  $1001^2$
9. Find whether each of the following numbers is a perfect square or not?  
(i) 121 (ii) 55 (iii) 81 (iv) 49 (v) 69
10. Express the following as the sum of two consecutive integers.  
(i)  $21^2$  (ii)  $13^2$  (iii)  $11^2$  (iv)  $19^2$
11. (i) Express 49 as the sum of 7 odd numbers.  
(ii) Express 121 as the sum of 11 odd numbers.
12. How many numbers lie between squares of the following numbers?  
(i) 12 and 13 (ii) 25 and 26 (iii) 99 and 100
13. Find the square of the following numbers without actual multiplication.  
(i) 39 (ii) 42
14. Find the squares of the following numbers containing 5 in unit’s place.  
(i) 15 (ii) 95 (iii) 105 (iv) 205
15. Write a Pythagorean triplet whose smallest member is 8.
16. Find a Pythagorean triplet in which one member is 12.
17. Write a Pythagorean triplet whose one member is.  
(i) 6 (ii) 14 (iii) 16 (iv) 18
18. By repeated subtraction of odd numbers starting from 1, find whether the following numbers are perfect squares or not? If the number is a perfect square then find its square root.  
(i) 121 (ii) 55 (iii) 36 (iv) 49 (v) 90

19. Find the square root of 6400.
20. Is 2352 a perfect square? If not, find the smallest multiple of 2352 which is a perfect square. Find the square root of the new number.
21. Find the smallest number by which 9408 must be divided so that the quotient is a perfect square. Find the square root of the quotient.
22. Find the smallest square number which is divisible by each of the numbers 6, 9 and 15.
23. Find the square roots of 100 and 169 by the method of repeated subtraction.
24. Find the square roots of the following numbers by the Prime Factorisation Method.  
(i) 729 (ii) 400 (iii) 1764 (iv) 4096 (v) 7744
25. 2025 plants are to be planted in a garden in such a way that each row contains as many plants as the number of rows. Find the number of rows and the number of plants in each row.
26. Find the smallest square number that is divisible by each of the numbers 4, 9 and 10.
27. Find the smallest square number that is divisible by each of the numbers 8, 15 and 20.
28. Find the square root of : (i) 729 (ii) 1296
29. Find the least number that must be subtracted from 5607 so as to get a perfect square. Also find the square root of the perfect square.
30. Find the greatest 4-digit number which is a perfect square.
31. Find the least number that must be added to 1300 so as to get a perfect square. Also find the square root of the perfect square.
32. Find the square root of 12.25.
33. Area of a square plot is 2304 m<sup>2</sup>. Find the side of the square plot.
34. There are 2401 students in a school. P.T. teacher wants them to stand in rows and columns such that the number of rows is equal to the number of columns. Find the number of rows.
35. Find the least number which must be subtracted from 1989 so as to get a perfect square. Also find the square root of the perfect square so obtained.
36. Find the least number which must be added to 1750 so as to get a perfect square. Also find the square root of the perfect square so obtained.
37. Find the length of the side of a square whose area is 441 m<sup>2</sup>.
38. In a right triangle ABC,  $\angle B = 90^\circ$ .  
(a) If AB = 6 cm, BC = 8 cm, find AC (b) If AC = 13 cm, BC = 5 cm, find AB
39. A gardener has 1000 plants. He wants to plant these in such a way that the number of rows and the number of columns remain same. Find the minimum number of plants he needs more for this.
40. There are 500 children in a school. For a P.T. drill they have to stand in such a manner that the number of rows is equal to number of columns. How many children would be left out in this arrangement.

**ASSIGNMENT QUESTIONS**  
**CLASS VIII: CHAPTER - 6**  
**SQUARES AND SQUARE ROOTS**

1. Which are the digits the square number can have at units place?
2. How many 2's are there in the prime factors of 300?
3. How many 5's are there in the prime factors of 13000?
4. How many digits will be there in the square root of 12321?
5. How much is  $45^2 - 44^2$ ?
6. Find the value of  $(39 + 21)^2$ .
7. What is the missing digit in  $(37)^2 = 136 - ?$
8. Find the value of  $121^2 - 120^2$ .
9. Simplify and give the answer :  $\sqrt{62 \times 28}$ .
10. How many natural nos lie between 562 and 572.
11. What is the square of  $\frac{19}{20}$
12. Find the square of (3.1).
13. How much is  $(0.1)^2$ ?
14. Find the value of  $\sqrt{0.0081}$ .
15. Give the square number between 36 and 64.
16. How many square numbers lie between 81 and 225?
17. Find the least number which when added to 599 to make it a perfect square.
18. In a cinema hall 729 people are seated in such a way that the number of people in a row is equal to number of rows. Then how many rows of people are there in the hall?
19. The length of a rectangular park is 80m and breadth is 60m. Find the length of its diagonal.
20. Give one Pythagorean triplet in which one of the number is 12.
21. Find the smallest number which when multiplied by 180 makes it a perfect square.
22. If the area of a square is 38.44 sq. cm. then find the side of the square.
23. A rectangular paper of length 45cm and breadth 5 cm is cut to form a square with the same area. What is the side of the square?



24. Find the least number by which 200 must be multiplied to make it a perfect square.
  25. Find the least number by which 384 must be divided to make it a perfect square
  26. Find the square root of 529 using long division method.
  27. Find the square root of 6.0516 Find the least number, which must be subtracted from 3250 to make it a perfect square
  28. Find the least number, which must be added to 1825 to make it a perfect square
  29. Find the square root of 3 correct to two places of decimal.
  30. Find the length of the side of a square where area is  $441 \text{ m}^2$ .
- .....

**MCQ WORKSHEET-I**  
**CLASS VIII: CHAPTER - 7**  
**CUBES AND CUBE ROOTS**

1. Which is the smallest three-digit perfect cube?  
(a) 125                      (b) 343                      (c) 729                      (d) 512
2. Which is the greatest three-digit perfect cube?  
(a) 125                      (b) 343                      (c) 729                      (d) 512
3. Which of the following is not a perfect cube ?  
(a) 1                      (b) 9                      (c) 8                      (d) 27
4. The cube of 4 is \_\_\_\_\_ .  
(a) 12                      (b) 8                      (c) 4                      (d) 64
5. The value of  $5^3$  is \_\_\_\_\_ .  
(a) 125                      (b) 15                      (c) 10                      (d) 75
6. The cube of an even number is always \_\_\_\_\_ .  
(a) odd number              (b) even number              (c) prime number              (d) none of these
7. The cube of an odd number is always \_\_\_\_\_ .  
(a) odd number              (b) even number              (c) prime number              (d) none of these
8. Each prime factor appears \_\_\_\_\_ times in its cube?  
(a) 2                      (b) 3                      (c) 1                      (d) 4
9. Which of the following is Hardy-Ramanujan Number ?  
(a) 1724                      (b) 1725                      (c) 1727                      (d) 1729
10. By which smallest natural number 392 must be multiplied so as to make the product a perfect cube ?  
(a) 2                      (b) 14                      (c) 7                      (d) 49
11. The smallest natural number by which 243 must be multiplied to make the product a perfect cube is \_\_\_\_\_ .  
(a) 3                      (b) 9                      (c) 8                      (d) 7
12. The smallest natural number by which 704 must be divided to obtain a perfect cube is  
(a) 22                      (b) 12                      (c) 11                      (d) 13
13. The smallest natural number by which 135 must be divided to obtain a perfect cube is  
(a) 5                      (b) 3                      (c) 15                      (d) 9
14. Which of the following is not a perfect cube ?  
(a) 216                      (b) 343                      (c) 125                      (d) 108
15. The expansion of  $a^3$  is \_\_\_\_\_ .  
(a)  $3 \times a$                       (b)  $a+a+a$                       (c)  $3 \times 3 \times 3$                       (d)  $a \times a \times a$

**MCQ WORKSHEET-II**  
**CLASS VIII: CHAPTER - 7**  
**CUBES AND CUBE ROOTS**

1. What will be the unit digit of the cube of a number ending with 2 ?  
(a) 8                      (b) 4                      (c) 2                      (d) 6
2. What will be the unit digit of the cube of a number ending with 4 ?  
(a) 4                      (b) 6                      (c) 2                      (d) 8
3. What will be the unit digit of the cube of a number ending with 6 ?  
(a) 4                      (b) 6                      (c) 2                      (d) 8
4. A cuboid has dimensions 5cm , 2cm, 5cm .How many such cuboid will be needed to form a cube ?  
(a) 20                      (b) 10                      (c) 5                      (d) 2
5. How many cuboids of dimensions 15cm, 30cm ,15cm will be needed to form a cube ?  
(a) 15                      (b) 4                      (c) 30                      (d) 5
6. 729 is the value of \_\_\_\_\_ .  
(a)  $8^3$                       (b)  $9^3$                       (c)  $6^3$                       (d)  $4^3$
7. Which of the following is a perfect cube ?  
(a) 125                      (b) 135                      (c) 145                      (d) 115
8. What is the volume of a cube whose edge is 2cm ?  
(a) 8                      (b) 6                      (c) 10                      (d) 4
9. The symbol for cube root is \_\_\_\_\_ .  
(a)  $\sqrt{\quad}$                       (b)  $\sqrt[3]{\quad}$                       (c)  $\sqrt[4]{\quad}$                       (d) none of these
10. The cube root of 512 is \_\_\_\_\_ .  
(a) 8                      (b) 32                      (c) 16                      (d) 2
11. The value of  $\sqrt[3]{343}$  is \_\_\_\_\_.  
(a) 8                      (b) 7                      (c) 6                      (d) 3
12. Which of the following is true for any natural number n?  
(a)  $n^2 > n^3$                       (b)  $n^3 > n^2$                       (c)  $n^2 = n^3$                       (d) none of these
13. If the volume of a cube is 125 cm<sup>3</sup> then what would be the length of its side?  
(a) 25                      (b) 5                      (c) 4                      (d) 15
14. What will be the unit digit of the cube root of a number ends with 8?  
(a) 2                      (b) 8                      (c) 4                      (d) 6
15. What will be the unit digit of the cube root of a number ends with 2?  
(a) 2                      (b) 8                      (c) 4                      (d) 6

**MCQ WORKSHEET-III**  
**CLASS VIII: CHAPTER - 7**  
**CUBES AND CUBE ROOTS**

1. What will be the unit digit of the cube root of a number ends with 3?  
(a) 3                      (b) 7                      (c) 5                      (d) 2
2. What will be the unit digit of the cube root of a number ends with 7?  
(a) 3                      (b) 7                      (c) 6                      (d) 5
3. 9 is the cube root of \_\_\_\_\_ .  
(a) 343                      (b) 729                      (c) 629                      (d) 81
4. The number of digits in the cube root of a 6-digit number is \_\_\_\_\_ .  
(a) 3                      (b) 2                      (c) 4                      (d) 6
5. How many digits will be there in the cube root of 46656 ?  
(a) 2                      (b) 1                      (c) 3                      (d) 4
6. How many digits will be there in the cube root of 512 ?  
(a) 1                      (b) 2                      (c) 3                      (d) 4
7. What will be the unit digit of  $\sqrt[3]{15625}$  ?  
(a) 5                      (b) 0                      (c) 3                      (d) 4
8. How many zeros will be there in the cube root of 27000?  
(a) 3                      (b) 0                      (c) 1                      (d) 2
9. How many zeros will be there in the cube root of 800?  
(a) 3                      (b) 0                      (c) 1                      (d) cube root does not exist
10. If  $7^3=343$  , then  $\sqrt[3]{343} =$  \_\_\_\_\_ .  
(a) 3                      (b) 7                      (c) 13                      (d) 9
11. If  $8^3=512$  , then  $\sqrt[3]{512} =$  \_\_\_\_\_ .  
(a) 3                      (b) 7                      (c) 13                      (d) 9
12. What will be the unit digit of  $\sqrt[3]{216}$  ?  
(a) 3                      (b) 6                      (c) 4                      (d) 2
13. Find the one's digit of the cube of 149  
(a) 2                      (b) 3                      (c) 9                      (d) none of these
14. Find the cube root of 8000.  
(a) 20                      (b) 200                      (c) 40                      (d) none of these
15. Find the cube root of 0.0027.  
(a) 3                      (b) 0.3                      (c) 0.03                      (d) none of these

**PRACTICE QUESTIONS**  
**CLASS VIII: CHAPTER - 7**  
**CUBES AND CUBE ROOTS**

1. Find the one's digit of the cube of each of the following numbers.  
(i) 3331 (ii) 8888 (iii) 149 (iv) 1005 (v) 1024 (vi) 77 (vii) 5022 (viii) 53
2. Express the following numbers as the sum of odd numbers using the pattern?  
(a)  $6^3$  (b)  $8^3$  (c)  $7^3$
3. Which of the following are perfect cubes?  
1. 400      2. 3375      3. 8000      4. 15625      5. 9000      6. 6859
4. Is 392 a perfect cube? If not, find the smallest natural number by which 392 must be multiplied so that the product is a perfect cube.
5. Is 53240 a perfect cube? If not, then by which smallest natural number should 53240 be divided so that the quotient is a perfect cube?
6. Is 1188 a perfect cube? If not, by which smallest natural number should 1188 be divided so that the quotient is a perfect cube?
7. Is 68600 a perfect cube? If not, find the smallest number by which 68600 must be multiplied to get a perfect cube.
8. Check which of the following are perfect cubes.  
(i) 2700 (ii) 16000 (iii) 64000 (iv) 900 (v) 125000 (vi) 36000 (vii) 21600 (viii) 10,000
9. Find the smallest number by which 256 must be multiplied to obtain a perfect cube.
10. Find the smallest number by which 192 must be divided to obtain a perfect cube.
11. Parikshit makes a cuboid of plasticine of sides 5 cm, 2 cm, 5 cm. How many such cuboids will he need to form a cube?
12. Find the cube root of 8000.
13. Find the cube root of 13824 by prime factorisation method.
14. Find the cube root of 17576 through estimation.
15. You are told that 1,331 is a perfect cube. Can you guess without factorisation what is its cube root? Similarly, guess the cube roots of 4913, 12167, 32768.
16. Find the cube root of each of the following numbers by prime factorisation method.  
(i) 64 (ii) 512 (iii) 10648 (iv) 27000 (v) 15625 (vi) 13824  
(vii) 110592 (viii) 46656 (ix) 175616 (x) 91125
17. Evaluate:  $\sqrt[3]{\frac{216}{2197}}$ .
18. Evaluate:  $\sqrt[3]{\frac{-125}{512}}$ .
19. Evaluate:  $\sqrt[3]{\frac{-1728}{2744}}$ .
20. Evaluate:  $\sqrt[3]{64 \times 729}$

# ASSIGNMENT QUESTIONS

## CLASS VIII: CHAPTER - 7

### CUBES AND CUBE ROOTS

1. Find the cube root of (a)512.(b)  $27 \times 64$
2. Is 243 a perfect cube? If not find the smallest number by which 243 must be multiplied to get a perfect cube
3. Is 250 a perfect cube? If not, then by which smallest natural number should 250 be divided so that the quotient is a perfect cube?
4. Find the cube root of  $\frac{125}{216}$  and  $\frac{-512}{1000}$ .
5. Find the cube root of 0.027.
6. What is the cube root of 0.001728?
7. Find the value of  $\frac{\sqrt[3]{729} - \sqrt[3]{27}}{\sqrt[3]{512} + \sqrt[3]{343}}$ .
8. The volume of a cubical box is 19.683 cu. cm. Find the length of each side of the box.
9. Find the smallest number by which the number 108 must be multiplied to obtain a perfect cube
10. Find the smallest number by which the number 88 must be divided to obtain a perfect cube
11. The volume of a cube is  $64 \text{ cm}^3$ . Find the side of the cube
12. If volume of a cube is  $216 \text{ cm}^3$ . What is the length of side of cube.
13. Three cubes of sides 3cm, 4cm and 5 cm respectively are melted to form a new cube. What is the side of new cube?
14. Simplify:  $15^3 - 14^3$
15. Simplify:  $\sqrt[3]{(1.1)^3} \times \sqrt[3]{1.331}$
16. Find the smallest number by which  $(2 \times 2 \times 3 \times 3 \times 3)$  is to be multiplied so that resultant number is a perfect cube.
17. Three solid wooden cubes of different colours with sides, 30 cm are placed side by side. How much cubic cm of wood is required to make it?
18. A cubical box has a volume of 512000 cubic cm. What is the length of the side of box?
19. Which least number should be multiplied by  $2 \times 2 \times 7 \times 7 \times 5 \times 7 \times 5 \times 5$  to get a perfect cube?
20. By which least number  $250 \times 512$  should be divided to make it a perfect cube.

**MCQ WORKSHEET-I**  
**CLASS VIII: CHAPTER - 8**  
**COMPARING QUANTITIES**

1. Find the ratio of 3 km to 300 m.  
a) 10 : 1                      b) 1 : 10                      c) 1 : 5                      d) none of these
2. A map is given with a scale of 2 cm = 1000 km. What is the actual distance between the two places in kms, if the distance in the map is 2.5 cm?  
a) 1250 km                      b) 1500 km                      c) 2500 km                      d) none of these
3. 6 bowls cost Rs 90. What would be the cost of 10 such bowls?  
a) Rs 300                      b) Rs 150                      c) Rs 200                      d) Rs 250
4. The car that I own can go 150 km with 25 litres of petrol. How far can it go with 30 litres of petrol?  
a) 125 km                      b) 150 km                      c) 250 km                      d) none of these
5. The ratio of 90 cm to 1.5 m is  
a) 2 : 5                      b) 3 : 5                      c) 4 : 5                      d) none of these
6. A picnic is being planned in a school for CLASS VIII. Girls are 60% of the total number of students and are 18 in number. The ratio of the number of girls to the number of boys in the class is  
a) 2 : 3                      b) 3 : 2                      c) 4 : 5                      d) none of these
7. Find the ratio of Speed of a cycle 15 km per hour to the speed of scooter 30 km per hour.  
a) 2 : 1                      b) 1 : 2                      c) 4 : 5                      d) none of these
8. Find the ratio of 5 m to 10 km  
a) 2000 : 1                      b) 1 : 2000                      c) 1 : 2                      d) none of these
9. Find the ratio of 50 paise to Rs 5  
a) 10 : 1                      b) 1 : 10                      c) 1 : 5                      d) none of these
10. 72% of 25 students are good in hindi, how many are not good in hindi?  
a) 16                      b) 14                      c) 18                      d) 7
11. In a computer lab, there are 3 computers for every 6 students. How many computers will be needed for 24 students?  
a) 12                      b) 14                      c) 16                      d) none of these
12. Out of 32 students, 8 are absent. What percent of the students are present?  
a) 75%                      b) 64%                      c) 60%                      d) none of these
13. There are 25 radios, 16 of them are out of order. What percent of radios are out of order?  
a) 75%                      b) 64%                      c) 60%                      d) none of these
14. A shop has 500 parts, out of which 5 are defective. What percent are not defective?  
a) 75%                      b) 99%                      c) 90%                      d) none of these
15. There are 120 voters, 90 of them voted yes. What percent voted yes?  
a) 75%                      b) 99%                      c) 90%                      d) none of these

**MCQ WORKSHEET-II**  
**CLASS VIII: CHAPTER - 8**  
**COMPARING QUANTITIES**

1. A survey of 40 children showed that 25% liked playing football. How many children not liked playing football?  
a) 90                      b) 60                      c) 30                      d) none of these
2. 8% children of a class of 25 like getting wet in the rain. How many children do not like getting wet in the rain.  
a) 20                      b) 22                      c) 23                      d) none of these
3. Rahul bought a sweater and saved Rs 20 when a discount of 25% was given. What was the price of the sweater before the discount?  
a) Rs 30                      b) Rs 40                      c) Rs 60                      d) Rs 80
4. Out of 15,000 voters in a constituency, 60% voted. Find the number of voters who did not vote.  
a) 9000                      b) 6000                      c) 3000                      d) none of these
5. Meeta saves Rs 400 from her salary. If this is 10% of her salary. What is her salary?  
a) 4000                      b) 6000                      c) 3000                      d) none of these
6. A local cricket team played 20 matches in one season. It won 25% of them. How many matches did they lose?  
a) 12                      b) 14                      c) 16                      d) none of these
7. A school team won 6 games this year against 4 games won last year. What is the per cent increase?  
a) 75%                      b) 50%                      c) 60%                      d) none of these
8. The number of illiterate persons in a country decreased from 150 lakhs to 100 lakhs in 10 years. What is the percentage of decrease?  
a) 30%                      b) 50%                      c)  $33\frac{1}{3}\%$                       d) none of these
9. Cost of an item is Rs 50. It was sold with a profit of 12%. Find the selling price.  
a) Rs 56                      b) Rs 60                      c) Rs 70                      d) none of these
10. How much will an item cost if 10% discount is given on the marked price Rs 100  
a) 90                      b) 110                      c) 95                      d) 85
11. A football team won 10 matches out of the total number of matches they played. If their win percentage was 40, then how many matches did they play in all?  
a) 10                      b) 25                      c) 40                      d) none of these
12. If Chameli had Rs 600 left after spending 75% of her money, how much did she have in the beginning?  
a) Rs 3000                      b) Rs 2400                      c) Rs 2600                      d) Rs 2800



**MCQ WORKSHEET-III**  
**CLASS VIII: CHAPTER - 8**  
**COMPARING QUANTITIES**

1. The price of a scooter was Rs 34,000 last year. It has increased by 20% this year. What is the price now?  
a) Rs 40800      b) Rs 32300      c) Rs 40000      d) none of these
2. The price of a scooter was Rs 34,000 last year. It has decreased by 5% this year. What is the price now?  
a) Rs 40800      b) Rs 32300      c) Rs 40000      d) none of these
3. Mohit bought a CD for Rs. 750 and sold it Rs. 875. Find his gain or loss percent.  
a) 5%      b) 16%      c) 6%      d)  $16\frac{2}{3}\%$
4. Rahul purchased a table for Rs. Rs. 1260 and due to some scratches on its top he had to sell it for Rs. 1197. Find his loss or gain percent.  
a) 5%      b) 4%      c) 6%      d)  $16\frac{2}{3}\%$
5. Raghu bought an almirah for Rs. 6250 and spent Rs. 375 on its repairs. Then he sold it for Rs. Rs. 6890. Find his gain or loss percent.  
a) 5%      b) 4%      c) 6%      d)  $16\frac{2}{3}\%$
6. A vendor bought oranges at Rs. 20 for Rs. 56 and sold them at Rs. 35 per dozen. Find his gain or loss percent.  
a) 5%      b)  $4\frac{1}{6}\%$       c) 6%      d)  $16\frac{2}{3}\%$
7. The cost of a flower vase is Rs 120. If the shopkeeper sells it at a loss of 10%, find the price at which it is sold.  
a) Rs 108      b) Rs 450      c) Rs 160      d) none of these
8. Selling price of a toy car is Rs 540. If the profit made by shopkeeper is 20%, what is the cost price of this toy?  
a) Rs 108      b) Rs 450      c) Rs 160      d) none of these
9. The marked price of a ceiling fan is Rs. 1250 and the shopkeeper allows a discount of 6% on it. Find the selling price of the fan.  
a) Rs 1180      b) Rs 1175      c) Rs 1160      d) none of these
10. A trader marks his goods at 40% above the cost price and allows a discount of 25%. What is his gain?  
a) Rs 118      b) Rs 175      c) Rs 105      d) none of these
11. A dealer purchased a washing for Rs. 7660. He allows a discount of 12% on its marked price and still gains 10%. Find the marked price of the machine.  
a) Rs 9800      b) Rs 9675      c) Rs 9575      d) none of these
12. On selling a fan for Rs. 810. Sunil gains 8%. For how much did he purchase it?  
a) Rs 780      b) Rs 750      c) Rs 760      d) none of these

**MCQ WORKSHEET-IV**  
**CLASS VIII: CHAPTER - 8**  
**COMPARING QUANTITIES**

1. On selling a table for Rs. 987. Ramesh loses 6%. For how much did he purchase it?  
a) Rs 1500      b) Rs 105      c) Rs 1050      d) none of these
2. Rashmi buys a calculator for Rs. 720 and sells it at a loss of  $6\frac{2}{3}\%$ . For how much does she sell it?  
a) Rs 700      b) Rs 650      c) Rs 672      d) none of these
3. The boys and girls in a school are in the ratio of 8 : 5. If the number of girls is 160, what is the total strength of the school?  
a) 250      b) 260      c) 356      d) 416
4. The simple interest on Rs. 5000 for 219 days at 4% per annum is  
a) Rs 126.50      b) Rs 120      c) Rs 125      d) Rs. 43.80
5. Find the simple interest on Rs. 2500 for 2 years 6 months at 6% per annum.  
a) Rs 350      b) Rs 375      c) Rs 750      d) none of these
6. What sum will amount to Rs. 4590 at 12% per annum simple interest in 3 years?  
a) Rs 3500      b) Rs 3375      c) Rs 3750      d) none of these
7. In what time will Rs. 1860 amount to Rs. 2278.50, if simple interest is calculated at 9% per annum?  
a) 2 years      b)  $2\frac{1}{2}$  years      c) 3 years      d) 4 years
8. At what rate percent per annum will Rs. 1650 amount to Rs. 2046 in 3 years?  
a) 8%      b) 4%      c) 6%      d)  $16\frac{2}{3}\%$
9. Simple interest on a certain sum is  $\frac{16}{25}$  of the sum. Find the rate percent and the time if both are numerically equal.  
a) 6 years      b)  $2\frac{1}{2}$  years      c) 8 years      d) 4 years
10. At what rate percent per annum simple interest will a sum treble itself in 16 years?  
a) 12%      b) 12.5%      c) 15%      d)  $16\frac{2}{3}\%$
11. A sum of money at simple interest amounts to Rs. 696 in 2 years and Rs. 840 in 5 years. The sum is  
a) Rs 500      b) Rs 600      c) Rs 560      d) Rs. 620

12. In what time will Rs. 1600 amount to Rs. 1768 at 6% per annum simple interest?  
a)  $1\frac{1}{4}$  years      b)  $2\frac{1}{2}$  years      c)  $1\frac{3}{4}$  years      d)  $1\frac{1}{2}$  years
13. A sum amounts to Rs. 3720 in 8 months at 5% per annum simple interest. The sum is  
a) Rs 3500      b) Rs 3600      c) Rs 3560      d) Rs. 3620
14. At what rate percent per annum simple interest will a sum be double itself in 8 years?  
a) 15%      b) 14%      c) 16%      d)  $12\frac{1}{2}$  %
15. At simple interest a sum becomes of itself in 5 years. The rate of interest percent per annum is  
a) 8%      b) 5%      c) 10%      d) 12%
- .....

**MCQ WORKSHEET-V**  
**CLASS VIII: CHAPTER - 8**  
**COMPARING QUANTITIES**

1. What amount Heena has to pay at the end of 2 years on a sum of Rs 20,000 at an interest of 8% compounded annually?  
a) Rs 23328                      b) Rs 23000                      c) Rs 23350                      d) Rs 23450
2. What will be the bill amount if the cost of a toy is Rs 450 and the sales tax charge is 5%?  
a) Rs 472.5                      b) Rs 437.5                      c) Rs 460                      d) Rs 455
3. The compounded interest on Rs. 50,000 at 8% per annum for 2 years, compounded annually is  
a) Rs 8000                      b) Rs 8250                      c) Rs 8350                      d) Rs 8640
4. At what rate percent per annum will a sum of Rs. 7500 amount to Rs. 8427 in 2 years compounded annually?  
a) 5%                      b) 4%                      c) 6%                      d) 8%
5. The compounded interest on Rs. 30000 at 7% per annum for a certain time is Rs. 4347. The time is  
a) 2 years                      b)  $2\frac{1}{2}$  years                      c) 3 years                      d) 4 years
6. The principal that amounts to Rs. 4913 in 3 years at  $6\frac{1}{4}$  % per annum compound interest, compounded annually is  
a) Rs 3096                      b) Rs 4076                      c) Rs 4085                      d) Rs 4096
7. If the simple interest on a sum of money at 5% per annum for 3 years is Rs. 1200, then the compound interest on the same sum for the same period at the same rate will be  
a) Rs 1225                      b) Rs 1236                      c) Rs 1248                      d) Rs 1261
8. If the compound interest on a sum for 2 years at  $12\frac{1}{2}$  % per annum is Rs. 510, the simple interest on the same sum at the same rate for same period of time is  
a) Rs 400                      b) Rs 450                      c) Rs 460                      d) Rs 480
9. The difference between compound interest and simple interest on a sum of Rs. 15000 for 2 years is Rs. 96. What is the rate of interest percent per annum?  
a) 10%                      b) 12%                      c) 6%                      d) 8%
10. The compounded interest on Rs. 8,000 at 5% per annum for 3 years, compounded annually is  
a) Rs 1225                      b) Rs 1236                      c) Rs 1248                      d) Rs 1261
11. The compounded interest on Rs. 6400 at  $7\frac{1}{2}$  % per annum for 2 years, compounded annually is  
a) Rs 7096                      b) Rs 7396                      c) Rs 7000                      d) none of these
12. In what time will be Rs. 1000 amount to Rs. 1331 at 10% per annum compounded annually?  
a) 2 years                      b)  $2\frac{1}{2}$  years                      c) 3 years                      d) 4 years

**PRACTICE QUESTIONS**  
**CLASS VIII: CHAPTER - 8**  
**COMPARING QUANTITIES**

1. Find the ratio of 3 km to 300 m.
2. A map is given with a scale of 2 cm = 1000 km. What is the actual distance between the two places in kms, if the distance in the map is 2.5 cm?
3. 6 bowls cost Rs 90. What would be the cost of 10 such bowls?
4. The car that I own can go 150 km with 25 litres of petrol. How far can it go with 30 litres of petrol?
5. In a computer lab, there are 3 computers for every 6 students. How many computers will be needed for 24 students?
6. Mala has a collection of bangles. She has 20 gold bangles and 10 silver bangles. What is the percentage of bangles of each type? Put it in the tabular form?
7. Out of 25 children in a class, 15 are girls. What is the percentage of girls?
8. Convert the given decimals to per cents: (a) 0.75 (b) 0.09 (c) 0.2
9. Out of 32 students, 8 are absent. What percent of the students are absent?
10. There are 25 radios, 16 of them are out of order. What percent of radios are out of order?
11. A shop has 500 parts, out of which 5 are defective. What percent are defective?
12. There are 120 voters, 90 of them voted yes. What percent voted yes?
13. If 65% of students in a class have a bicycle, what percent of the student do not have bicycles?
14. We have a basket full of apples, oranges and mangoes. If 50% are apples, 30% are oranges, then what percent are mangoes?
15. A survey of 40 children showed that 25% liked playing football. How many children liked playing football?
16. Find: (a) 50% of 164 (b) 75% of 12 (c)  $12\frac{1}{2}$ % of 64
17. 8% children of a class of 25 like getting wet in the rain. How many children like getting wet in the rain.
18. Rahul bought a sweater and saved Rs 20 when a discount of 25% was given. What was the price of the sweater before the discount?
19. 9 is 25% of what number?
20. 75% of what number is 15?

21. Reena's mother said, to make *idlis*, you must take two parts rice and one part *urad dal*. What percentage of such a mixture would be rice and what percentage would be *urad dal*?
22. If Rs 250 is to be divided amongst Ravi, Raju and Roy, so that Ravi gets two parts, Raju three parts and Roy five parts. How much money will each get? What will it be in percentages?
23. Divide 15 sweets between Manu and Sonu so that they get 20 % and 80 % of them respectively.
24. If angles of a triangle are in the ratio 2 : 3 : 4. Find the value of each angle.
25. A school team won 6 games this year against 4 games won last year. What is the per cent increase?
26. The number of illiterate persons in a country decreased from 150 lakhs to 100 lakhs in 10 years. What is the percentage of decrease?
27. Find Percentage of increase or decrease: – Price of shirt decreased from Rs 80 to Rs 60. – Marks in a test increased from 20 to 30.
28. My mother says, in her childhood petrol was Re 1 a litre. It is Rs 52 per litre today. By what Percentage has the price gone up?
29. The cost of a flower vase is Rs 120. If the shopkeeper sells it at a loss of 10%, find the price at which it is sold.
30. Selling price of a toy car is Rs 540. If the profit made by shopkeeper is 20%, what is the cost price of this toy?
31. A shopkeeper bought a chair for Rs 375 and sold it for Rs 400. Find the gain Percentage.
32. Cost of an item is Rs 50. It was sold with a profit of 12%. Find the selling price.
33. An article was sold for Rs 250 with a profit of 5%. What was its cost price?
34. An item was sold for Rs 540 at a loss of 5%. What was its cost price?
35. Anita takes a loan of Rs 5,000 at 15% per year as rate of interest. Find the interest she has to pay at end of one year.
36. Rs 10,000 is invested at 5% interest rate p.a. Find the interest at the end of one year.
37. Rs 3,500 is given at 7% p.a. rate of interest. Find the interest which will be received at the end of two years.
38. Rs 6,050 is borrowed at 6.5% rate of interest p.a.. Find the interest and the amount to be paid at the end of 3 years.
39. Rs 7,000 is borrowed at 3.5% rate of interest p.a. borrowed for 2 years. Find the amount to be paid at the end of the second year.
40. If Manohar pays an interest of Rs 750 for 2 years on a sum of Rs 4,500, find the rate of interest.

41. You have Rs 2,400 in your account and the interest rate is 5%. After how many years would you earn Rs 240 as interest.
42. On a certain sum the interest paid after 3 years is Rs 450 at 5% rate of interest per annum. Find the sum.
43. In what time will Rs. 1860 amount to Rs. 2278.50, if simple interest is calculated at 9% per annum?
44. Simple interest on a certain sum is  $\frac{16}{25}$  of the sum. Find the rate percent and the time if both are numerically equal.
45. In what time will Rs. 1600 amount to Rs. 1768 at 6% per annum simple interest?
46. At what rate percent per annum simple interest will a sum be double itself in 8 years?
47. At what rate percent per annum simple interest will a sum treble itself in 16 years?
48. A sum amounts to Rs. 3720 in 8 months at 5% per annum simple interest. Find the sum.
49. A sum of Rs 10,000 is borrowed at a rate of interest 15% per annum for 2 years. Find the simple interest on this sum and the amount to be paid at the end of 2 years.
50. A man got a 10% increase in his salary. If his new salary is Rs 1,54,000, find his original salary.
51. A picnic is being planned in a school for Class VII. Girls are 60% of the total number of students and are 18 in number. The picnic site is 55 km from the school and the transport company is charging at the rate of Rs 12 per km. The total cost of refreshments will be Rs 4280. Find the
- ratio of the number of girls to the number of boys in the class?
  - cost per head if two teachers are also going with the class?
  - If their first stop is at a place 22 km from the school, what per cent of the total distance of 55 km is this? What per cent of the distance is left to be covered?
52. The price of a scooter was Rs 34,000 last year. It has increased by 20% this year. What is the price now?
53. An item marked at Rs 840 is sold for Rs 714. What is the discount and discount %? The list price of a frock is Rs 220.
54. The list price of a frock is Rs 220. A discount of 20% is announced on sales. What is the amount of discount on it and its sale price.
55. A shop gives 20% discount. What would the sale price of each of these be? (a) A dress marked at Rs 120 (b) A pair of shoes marked at Rs 750 (c) A bag marked at Rs 250
56. A table marked at Rs 15,000 is available for Rs 14,400. Find the discount given and the discount per cent.
57. An almirah is sold at Rs 5,225 after allowing a discount of 5%. Find its marked price.
58. Sohan bought a second hand refrigerator for Rs 2,500, then spent Rs 500 on its repairs and sold it for Rs 3,300. Find his loss or gain per cent.

- 59.** Find selling price (SP) if a profit of 5% is made on  
 (a) a cycle of Rs 700 with Rs 50 as overhead charges.  
 (b) a lawn mower bought at Rs 1150 with Rs 50 as transportation charges.  
 (c) a fan bought for Rs 560 and expenses of Rs 40 made on its repairs.
- 60.** Meenu bought two fans for Rs 1200 each. She sold one at a loss of 5% and the other at a profit of 10%. Find the selling price of each. Also find out the total profit or loss.
- 61.** A shopkeeper purchased 200 bulbs for Rs 10 each. However 5 bulbs were fused and had to be thrown away. The remaining were sold at Rs 12 each. Find the gain or loss %.
- 62.** A shopkeeper bought two TV sets at Rs 10,000 each. He sold one at a profit 10% and the other at a loss of 10%. Find whether he made an overall profit or loss.
- 63.** The cost of a pair of roller skates at a shop was Rs 450. The sales tax charged was 5%. Find the bill amount.
- 64.** Waheeda bought an air cooler for Rs 3300 including a tax of 10%. Find the price of the air cooler before VAT was added.
- 65.** Find the buying price of each of the following when 5% ST is added on the purchase of (a) A towel at Rs 50  
 (b) Two bars of soap at Rs 35 each  
 (c) 5 kg of flour at Rs 15 per kg
- 66.** If 8% VAT is included in the prices, find the original price of  
 (a) A TV bought for Rs 13,500  
 (b) A shampoo bottle bought for Rs 180
- 67.** Two times a number is a 100% increase in the number. If we take half the number what would be the decrease in per cent?
- 68.** By what per cent is Rs 2,000 less than Rs 2,400? Is it the same as the per cent by which Rs 2,400 is more than Rs 2,000?
- 69.** A sum of Rs 10,000 is borrowed at a rate of interest 15% per annum for 2 years. Find the simple interest on this sum and the amount to be paid at the end of 2 years.
- 70.** Find CI on Rs 12600 for 2 years at 10% per annum compounded annually.
- 71.** What amount is to be repaid on a loan of Rs 12000 for  $1\frac{1}{2}$  years at 10% per annum compounded half yearly.
- 72.** Find CI paid when a sum of Rs 10,000 is invested for 1 year and 3 months at  $8\frac{1}{2}$ % per annum compounded annually.
- 73.** The population of a city was 20,000 in the year 1997. It increased at the rate of 5% p.a. Find the population at the end of the year 2000.
- 74.** A machinery worth Rs 10,500 depreciated by 5%. Find its value after one year. Find the population of a city after 2 years, which is at present 12 lakh, if the rate of increase is 4%



**HOT'S QUESTIONS**  
**CLASS VIII: CHAPTER - 8**  
**COMPARING QUANTITIES**

1. A man buys a plot of agricultural land for Rs. 300000. He sells one-third at a loss of 20% and two-fifths at a gain of 25%. At what price must he sell the remaining land so as to make an overall profit of 10%.
2. A man bought two TV sets for Rs. 42500. He sold one at a loss of 10% and other at a profit of 10%. If the selling price of each TV set is same, find the cost price of each set.
3. A man sold two articles at Rs. 25920 each. These were sold at 8% gain and 4% loss respectively. Find the gain or loss percent in the whole transaction.
4. A man bought an article and sold it at a gain of 10%. If he had bought it at 20% less and sold it for Rs. 10 more, he would have made profit of 40%. Find the C. P. of the article.
5. Three items are purchased at Rs. 450 each. One of them is sold at a loss of 10%. At what price should the other two be sold so as to gain 20% on the whole transaction? What is the gain % on the transaction?
6. By reducing the SP of an article by Rs. 50, a gain of 5% turns into a loss of 5%. Find the original SP of the article.
7. A dealer bought two tables for Rs. 3120. He sold one at a loss of 15% and other at a profit of 36%. If the selling price of each TV set is same, find the cost price of each table.
8. Pranshu bought two fans for Rs. 3605. He sold one at a profit of 15% and other at a loss of 9%. If the selling price of each TV set is same, find the cost price of each fan.
9. Prateeksha bought 16 dozen ball pens and sold them at a loss equal to SP of 8 ball pens. Find her loss% and SP of 1 dozen ball pens if she purchased these 16 dozen ball pens for Rs. 576.
10. The difference between two selling prices of a shirt at profits of 4% and 5% is Rs. 6. Find CP of the shirt and the two selling prices of the shirt.
11. Articles are marked at a price which gives a profit of 25%. After allowing a certain discount, the profit reduces to  $12\frac{1}{2}$ %. Find the discount percent.
12. A cycle merchant allows 25% commission on his advertised price and still makes a profit of 20%. If he gains Rs. 60 over the sale of one cycle, find his advertised price.
13. How much percent more than the CP should a manufacturer mark his goods so that after allowing a discount of 20% on the marked price, he gains 10%?
14. A trader buys certain items at 32% off the list price and he wants to make a profit of 25% after allowing a discount of 20%. At what percent above the list price should he mark the items?
15. A dealer of scientific instruments allows 20% discount on the marked price of the instruments and still makes a profit of 25%. If his gain over the sale of an instrument is Rs. 150, find the marked price of the instrument.

16. Ranjitha and Achala run a ready-made garment shop. They mark the garments at such a price that even after allowing a discount of  $12\frac{1}{2}\%$ , they make a profit of 10%. Find the marked price of a suit, which costs them Rs. 1470.
17. What price should Rajesh mark on a pair of shoes, which costs him Rs. 1200 so as to gain 12% after allowing a discount of 16%?
18. Aditi allows 4% discount on the marked price of her goods and still earns a profit of 20%. What is the cost price of a shirt marked at Rs. 850?
19. A shopkeeper offers 10% off-season discount to the customers and still makes a profit of 26%. What is the cost price for the shopkeeper on a pair of shoes marked at Rs. 1120?
20. Samir bought a shirt for Rs. 336, including 12% VAT and a necktie for Rs. 110 including 10% VAT. Find the printed price of shirt and necktie together.
21. Amit purchased a motorcycle, having marked price is Rs. 46000 at a discount of 5%. If VAT is charged at the rate of 10%, find the amount Amit has paid to purchase the motorcycle.
22. Shruti bought a set of cosmetic items for Rs. 345 including 15% VAT and a purse for Rs. 110 including 10% VAT. What percent is the VAT charged on the whole transaction?
23. List price of a washing machine is Rs. 9000. If the dealer allows a discount of 5% on the cash payment, how much money will a customer pay to the dealer in cash, if the rate of VAT is 10%?
24. Rakesh goes to a departmental store and purchases the following articles:
- biscuits and bakery products costing Rs. 50, VAT @ 5%.
  - medicine costing Rs. 90, VAT @ 10%.
  - clothes costing Rs. 400, VAT @ 1% and
  - cosmetics costing Rs. 150, VAT @ 10%.
- Calculate the total amount to be paid by Rakesh to the store.
25. Simple interest on a sum of money for 3 years at  $6\frac{1}{4}\%$  per annum is Rs. 2400. What will be the compound interest on that sum at the same rate for the same period?
26. Find the compound interest on Rs. 320000 for one year at the rate of 20% per annum, if the interest is compounded quarterly.
27. Aditya deposited Rs. 7500 in bank, which pays him 12% interest per annum compounded quarterly. What is the amount, which he receives after 9 months?
28. Ram singh buys a refrigerator for Rs. 4000 on credit. The rate of interest for the first year is 5% and of the second year is 15%. How much will it cost him if he pays the amount after two years?
29. Find the compound interest on Rs. 24000 at 15% per annum for  $2\frac{1}{3}$  years.
30. The difference between the compound interest and simple interest on a certain sum of money at 10% per annum for 2 years is Rs. 500. Find the sum when the interest is compounded annually.

31. The difference between the compound interest and simple interest on a certain sum of money at 15% per annum for 3 years is Rs. 283.50. Find the sum when the interest is compounded annually.
32. The difference between the compound interest and simple interest on a certain sum of money at  $6\frac{2}{3}$  % per annum for 3 years is Rs. 46. Find the sum when the interest is compounded annually.
33. Manoj borrowed from Ramesh certain sum for 2 years at S.I. Manoj lent this sum to Mahesh at the same rate for 2 years C.I. At the end of 2 years he received Rs. 110 as C.I. but paid Rs. 100 as S.I. Find the sum and rate of interest.
34. Manoj borrowed from Ramesh certain sum for 2 years at S.I. Manoj lent this sum to Mahesh at the same rate for 2 years C.I. At the end of 2 years he received Rs. 210 as C.I. but paid Rs. 200 as S.I. Find the sum and rate of interest.
35. Ashish opened a bookshop with an initial investment of Rs. 32000. In the first year, he incurred a loss of 5%. However, during the second year, he earned a profit of 10% which in the third year rose to  $12\frac{1}{2}$  %. Calculate his net profit for the entire period of 3 years.
36. 24000 blood donors were registered with a charitable hospital. The number of donors increased at the rate of 5% every six month. Find the time period at the end of which the total number of blood donors becomes 27783.
37. A factory increased its production of 3 wheelers from 80000 in 1999 to 92610 in 2002. Find the annual rate of growth of production of 3 wheelers.
38. The value of flat worth Rs. 500000 is depreciating at the rate of 10% per annum. In how many years will its value be reduced to Rs. 364500?
39. The value of a property increases every year at the rate of 5%. If its value at the end of 3 years be Rs. 411540, what was its original value at the beginning of these years?
40. Ashish started the business with an initial investment of Rs. 500000. In the first year, he incurred a loss of 4%. However, during the second year, he earned a profit of 5% which in the third year rose to 10%. Calculate his net profit for the entire period of 3 years.
- .....

**MCQ WORKSHEET-I**  
**CLASS VIII: CHAPTER - 09**  
**ALGEBRAIC EXPRESSIONS**

1. What are the coefficients of  $x$  in the expression  $8 - x + y$ ?  
(a) 1                      (b) -1                      (c) 8                      (d) none of these
  2. What are the coefficients of  $y$  in the expression  $4x - 3y$ ?  
(a) 4                      (b) -3                      (c) 3                      (d) none of these
  3. What are the coefficients of  $y$  in the expression  $yz^2 + 5$ ?  
(a) 5                      (b)  $z$                       (c)  $z^2$                       (d) none of these
  4. Write the expression for the statement: the sum of three times  $x$  and 11  
(a)  $x + 3 + 11$                       (b)  $3x + 11$                       (c)  $3 + 11x$                       (d)  $3x - 11$
  5. Write an expression : Raju s father s age is 5 years more than 3 times Raju s age . If Raju s age is  $x$  years , then father's age is  
(a)  $3x+5$                       (b)  $5-3x$                       (c)  $3x-5$                       (d)  $15x$
  6. Identify the coefficient of  $x$  in expression  $8 - x + y$   
(a) 0                      (b) 8                      (c) -1                      (d) 1
  7. The number of terms in  $4p^2q - 3pq^2 + 5$  is  
(a) 7                      (b) 3                      (c) 1                      (d) 4
  8. The expression for sum of numbers  $a$  and  $b$  subtracted from their product is  
(a)  $a + b - ab$                       (b)  $ab - a + b$                       (c)  $ab - (a+b)$                       (d)  $ab + a - b$ .
  9. The sum of  $mn + 5 - 2$  and  $mn+3$  is  
(a)  $2mn + 3$                       (b) 6                      (c)  $2mn + 8$                       (d)  $2mn + 6$ .
  10. What is the statement for the expression  $3mn + 5$   
(a) 5 more than  $\frac{1}{3}$  of product of  $m$  and  $n$   
(b) number 5 added to product of number  $m$  and  $n$   
(c) number 5 added to 3 times the product of  $m$  and  $n$ .  
(d) 5 more than 3 times the product of the numbers  $m$  and  $n$
  11. The constant term in the expression  $1 + x^2 + x$  is  
(a) 1                      (b) 2                      (c)  $x$                       (d)  $x^2$
  12. The coefficient of  $y^3$  in the expression  $y - y^3 + y^2$  is  
(a) 1                      (b)  $y$                       (c)  $-y^3$                       (d) -1
- .....

**MCQ WORKSHEET-II**  
**CLASS VIII: CHAPTER - 09**  
**ALGEBRAIC EXPRESSIONS**

1. The number of terms in the expression  $1.2ab - 2.4b + 3.6a$  is  
(a) 1.2                      (b) -2.4                      (c) 3.6a                      (d) 3
2. What is the numerical coefficient of  $y^2$  in the expression  $2x^2y - 15xy^2 + 7y$   
(a)  $-15x$                       (b)  $-15$                       (c) 2                      (d) 7
3. The expression  $x + y - xy$  is  
(a) Monomial                      (b) Binomial                      (c) Trinomial                      (d) Quadrinomial
4. The expression  $xyz$  is  
(a) Monomial                      (b) Binomial                      (c) Trinomial                      (d) Zero polynomial
5. From the following expressions  $10pq, 7p, 8q, -p^2q^2, -7pq, -23, ab, 3a, b$ . The like terms are  
(a)  $3, 7p$                       (b)  $10pq, -7pq$                       (c)  $ab, 3a, b$                       (d)  $10pq, 7p, 8q$
6. From the following expressions  $3ab, a^2, b^2, a, 5ab, -2ab, 2a^2$  the three terms are  
(a)  $3ab, 5ab, -2ab$                       (b)  $a^2, a, 2a^2$                       (c)  $3ab, a^2, b^2$                       (d)  $2a^2, a^2, a$
7. Sum of  $3m$  and  $2n$  is  
(a)  $5mn$                       (b)  $3m+2n$                       (c)  $5m$                       (d)  $5n$
8. Sum of  $xy, x+y$  and  $y+xy$  is  
(a)  $2xy + 2x+y$                       (b)  $3xy+2y$                       (c)  $2xy + x+y$                       (d)  $2xy+x+2y$
9. The value of  $21b - 32 + 7b - 20b$  is  
(a)  $48b - 32$                       (b)  $-8b - 32$                       (c)  $8b - 32$                       (d)  $28b - 52$
10. Subtract  $a - b$  from  $a + b$  the result is  
(a)  $2a + 2b$                       (b)  $2a$                       (c)  $2b$                       (d)  $2a - 2b$
11. Subtracting  $-5y^2$  from  $y^2$ , the result is  
(a)  $-4y^2$                       (b)  $6y^2$                       (c)  $4y^2$                       (d)  $-6y^2$
12. The value of expression  $5n - 2$ , when  $n = -2$  is  
(a)  $-12$                       (b) 8                      (c) 1                      (d)  $-8$
13. The value of expression  $7a - 4b$  for  $a = 3, b = 2$  is  
(a) 13                      (b)  $7a - 6b$                       (c)  $21a - 8b$                       (d) 29
14. When  $x = 0, y = -1$ , then the value of expression  $2x + 2y$  is  
(a) 4                      (b) 0                      (c)  $-2$                       (d) 2
15. Factors of the term  $15x^2$  in the expression  $15x^2 - 13x$  are  
(a) 15,  $x, x$                       (b) 15,  $-13$                       (c)  $15x^2, -13x$                       (d) 15

**MCQ WORKSHEET-III**  
**CLASS VIII: CHAPTER - 09**  
**ALGEBRAIC EXPRESSIONS**

1. Factors of the terms  $-4pq^2$  in the expression  $9p^2q^2 - 4pq^2$  are  
(a)  $9p^2q^2, -4pq^2$  (b)  $9, -4$  (c)  $-4, p, q, q$  (d)  $-4$
2. If the length of each side of the equilateral triangle is  $l$ , then the perimeter of the equilateral triangle is  
(a)  $3l$  (b)  $3+l$  (c)  $3-l$  (d)  $l/3$
3. Which of the following is monomial  
(a)  $2x + 3$  (b)  $2x$  (c)  $4x + 2y + 3$  (d)  $4y + 5x + z - 1$
4. Which of the following is trinomial  
(a)  $2a + 6b - 1$  (b)  $1$  (c)  $5a - 7$  (d)  $a + b + c - 3$
5. Terms with factors  $y$  in the expression  $8 + xy + xyz$  are  
(a)  $xy, xyz$  (b)  $x, xz$  (c)  $8, xy, xyz$  (d)  $y, xz$
6. Identify the terms in the expression  $x + y + 1$  which are not constant  
(a)  $x, y, 1$  (b)  $x, y$  (c)  $x, 1$  (d)  $y, 1$
7. The value of expression  $4x - 3$  at  $x=2$  is  
(a)  $-4$  (b)  $5$  (c)  $4$  (d)  $2$
8. The value of expression  $5n^2 + 5n - 2$  for  $n = -2$  is  
(a)  $13$  (b)  $3$  (c)  $8$  (d)  $12$
9. The value of expression  $2a^2 + 2b^2 - ab$  for  $a=2, b=1$  is  
(a)  $2$  (b)  $8$  (c)  $6$  (d)  $10$
10. The value of  $x + 7 + 4(x - 5)$  for  $x=2$   
(a)  $-3$  (b)  $31$  (c)  $12$  (d)  $37$
11. The value of expression  $2a - 2b - 4 - 5 + a$  at  $a=1, b=-2$   
(a)  $10$  (b)  $-2$  (c)  $12$  (d)  $-4$
12. What must be subtracted from  $2a + b$  to get  $2a - b$   
(a)  $2b$  (b)  $4a$  (c)  $0$  (d)  $4a+4b$
13. What must be added to  $3x + y$  to get  $2x + 3y$   
(a)  $5x + 4y$  (b)  $-x + 2y$  (c)  $x - 2y$  (d)  $x + 2y$
14. Subtract  $a + 2b$  from sum of  $a - b$  and  $2a+b$   
(a)  $2a - 2b$  (b)  $4a + 2b$  (c)  $2b$  (d)  $-2a + 2b$
15. On simplifying  $(a + b - 3) - (b - a + 3) + (a - b + 3)$  the result is  
(a)  $a - b + 3$  (b)  $a - b - 3$  (c)  $3a - b - 3$  (d)  $3a+b+3$
16. What should be value of 'a' if  $y^2 + y - a$  equals to  $3$  for  $y=1$   
(a)  $-1$  (b)  $-5$  (c)  $5$  (d)  $0$

17. What is an expression for the statement: “p is multiplied by 16”  
(a) 16p (b) p/16 (c) p+16 (d) p-16
18. The expression for the statement: “ y multiplied by 10 and then 7 added to product”.  
(a)  $10 + y + 7$  (b)  $7y + 10$  (c)  $10y + 7$  (d)  $10y$
19. What is the statement for the expression  $2y - 9$   
(a) 2y subtracted from 9 (b) 9 subtracted from y and multiplied by 2  
(c) 9 subtracted from 9 (d) thrice of y minus 9
20. Give expression for: “ 5 times of ‘y’ to which 3 is added”  
(a)  $y + 15$  (b)  $5y + 3$  (c)  $\frac{5}{y} + 3$  (d)  $3y + 5$
21. The equation for the statement: one fourth of a number minus 4 gives 4.  
(a)  $4x - 4 = 4$  (b)  $\frac{4}{x} - 4 = 4$  (c)  $\frac{1}{4}x - 4 = 4$  (d)  $x - 4 = \frac{1}{4}$
- .....

**MCQ WORKSHEET-IV**  
**CLASS VIII: CHAPTER - 09**  
**ALGEBRAIC EXPRESSIONS**

1. The number of terms in the expression  $2x^2 + 3x + 5$  is  
(a) 1                      (b) 2                      (c) 3                      (d) 5
2. The coefficient of  $x$  in the expression  $-7x + 5$  is  
(a) 5                      (b)  $-7$                       (c) 7                      (d)  $x$
3. The numerical coefficient of  $y$  in the expression  $2x + 3y + 7z$  is  
(a) 2                      (b) 3                      (c) 7                      (d)  $3y$
4. The expression  $y + z + 100$  is a  
(a) monomial                      (b) literal number  
(c) binomial                      (d) trinomial
5. The expression  $7xy$  has the factors  
(a) 7,  $x$ ,  $y$                       (b)  $x$ ,  $y$                       (c) 7,  $x$                       (d) 7,  $y$
6. The common factors of the terms  $2y$ ,  $22xy$  is  
(a) 2                      (b)  $2y$                       (c)  $y$                       (d)  $xy$
7. '2' is common factor of the expressions  
(a)  $12a^2b$ ,  $15ab^2$                       (b)  $5xy$ ,  $10x$                       (c)  $10x^2$ ,  $-18x^3$ ,  $14x^4$                       (d)  $33y$ ,  $-22z$
8. The factorization of  $7a^2 + 14a$  is  
(a)  $7(a + z)$                       (b)  $21a$                       (c)  $7(a + 1)$                       (d)  $7a(a + 2)$
9. The addition of  $ab - bc$ ,  $bc - ca$ ,  $ca - ab$  is  
(a)  $3ab + 3bc + 3ca$                       (b) 0                      (c)  $ab + bc + ca$                       (d)  $ab - bc + ca$
10. One of the example of binomial is  
(a)  $3xyz$                       (b)  $3xy + z$                       (c)  $3x + y + z$                       (d)  $3 + x + y + z$
11. The area of triangle is 'xy' where 'x' is length and 'y' is breadth. If the length of rectangle is increased by 5 units and breadth is decreased by 3 units, the new area of rectangle will be  
(a)  $(x - y)(x + 3)$                       (b)  $xy + 15$                       (c)  $(x + 5)(y - 3)$                       (d)  $xy + 5 - 3$
12. The value of  $2x(-3x)$  is  
(a)  $5x^2$                       (b)  $-6x$                       (c)  $-5x^2$                       (d)  $-6x^2$
13. Like terms in the expression  $7x$ ,  $5x^2$ ,  $7y$ ,  $-5yx$ ,  $-9x^2$ , are  
(a)  $7x$ ,  $-5yx$                       (b)  $5x^2$ ,  $-5yx$                       (c)  $5x^2$ ,  $-9x^2$ ,                      (d)  $7x$ ,  $7y$
14. Area of rectangle of length '3x' and breadth '5y' is  
(a)  $3x + 5y$                       (b)  $15xy$                       (c)  $15x$                       (d)  $15y$
15. Number of terms in the expression  $xyz + 1$  is  
(a) 4                      (b) 3                      (c) 2                      (d) 1



**MCQ WORKSHEET-V**  
**CLASS VIII: CHAPTER - 09**  
**ALGEBRAIC EXPRESSIONS**

1. The product of  $-4p$  and  $7p$  is  
(a)  $28p$                       (b)  $-28p^2$                       (c)  $-28p$                       (d)  $28p^2$
2. The product of  $a^2$ ,  $2a^2$ ,  $5a^{10}$  is  
(a)  $10a^{34}$                       (b)  $7a^{34}$                       (c)  $10a^{22}$                       (d)  $10a^{40}$
3. Multiplication of  $pq + qr + rp$  and 'zero' is  
(a)  $pq + qr$                       (b)  $pq + rp$                       (c)  $pq + qr + rp$                       (d)  $0$
4. The value of  $3x(4x - 5) + 3$  for  $x=3$   
(a)  $-6$                       (b)  $66$                       (c)  $106$                       (d)  $0$
5. The volume of rectangular box whose length, breadth and height is  $2p$ ,  $4q$ ,  $8r$  respectively is  
(a)  $14pqr$                       (b)  $2p + 4q + 8r$                       (c)  $64pqr$                       (d)  $64$
6. Numerical coefficient of  $x^{2y}$  in the expression  $1 + x + 2x^{2y}$  is  
(a)  $2y$                       (b)  $2$                       (c)  $2x^{2y}$                       (d)  $2x^2$
7. Coefficient of  $xy$  in the expression  $\frac{x}{2} + \frac{y}{2} - xy$  is  
(a)  $-1$                       (b)  $\frac{1}{2}$                       (c)  $1$                       (d)  $\frac{1}{4}$
8. Which of the following expression is trinomial  
(a)  $xyz$                       (b)  $xy + z$                       (c)  $x + y + z$                       (d)  $x + yz$
9. Which of the following expression is monomial  
(a)  $x + 1$                       (b)  $pqr$                       (c)  $pq + r$                       (d)  $p + qr$
10. Multiplication of 'ab' and 'a-b' is  
(a)  $a^2b - b$                       (b)  $a^2b + b$                       (c)  $ba^2b + ab^2$                       (d)  $a^2b - ab^2$
11. The suitable identity to find  $(x + 3)(x + 3)$  is  
(a)  $(a + b)^2$                       (b)  $(a - b)^2$                       (c)  $a^2 - b^2$                       (d)  $(x + a)(x + b)$
12. Value of  $(4p - 3q)^2$  is  
(a)  $16p^2 - 9q^2$                       (b)  $16p^2 - 9q^2 + 24pq$                       (c)  $16p^2 - 9q^2 - 24pq$                       (d)  $16p^2 + 9q^2 - 24pq$
13.  $(9x + a)(x + b)$  is equal to  
(a)  $x^2 + ax + ab$                       (b)  $x^2 + (a + b)x + ab$                       (c)  $x^2 + bx + ab$                       (d)  $x^2 + ab$
14. Value of expression ' $a(a^2 + a + 1) + 5$ ' for ' $a = 0$ ' is  
(a)  $a + 5$                       (b)  $1$                       (c)  $6$                       (d)  $5$
15. Which of the following is not binomial  
(a)  $m + n$                       (b)  $mn$                       (c)  $m - n$                       (d)  $m^2 - n^2$

**MCQ WORKSHEET-VI**  
**CLASS VIII: CHAPTER - 09**  
**ALGEBRAIC EXPRESSIONS**

1. Subtracting  $7x + y$  from  $-x + y$  gives  
(a)  $6x + 2y$                       (b)  $8x + 2y$                       (c)  $-8x$                               (d)  $8x$
2. Which identity is used to evaluate  $(m + 3)(m + 2)$ .  
(a)  $(x + a)(x + b) = x^2 + (a + b)x + ab$                       (b)  $(a+b)^2 = a^2 + 2ab + b^2$   
(c)  $(a - b)^2 = a^2 - 2ab + b^2$                                       (d)  $a^2 - b^2 = (a + b)(a - b)$
3. Use suitable identity to evaluate  $99^2$ .  
(a) 9801                      (b) 10199                      (c) 10201                              (d) 10001
4. Evaluate  $(4x + y)^2$  by suitable identity  
(a)  $4x^2 + y^2 + 8x$                       (b)  $4x + y + 8xy$                       (c)  $16x^2 + y^2 + 8xy$                       (d)  $16x^2 + y^2 + 8$
5. Find the value of  $95 \times 102$  by suitable identity.  
(a) 10310                      (b) 10290                      (c) 10690                              (d) 9690
6. Simplification of  $(t + s^2)(t^2 - s)$  is  
(a)  $t^3 + s^3 - s^2t^2 - ts$                       (b)  $t^3 - s^3 + s^2t^2 - st$                       (c)  $t^3 - s^3 + s^2t^2 + st$                       (d)  $t^3 + s^3 - s^2t^2 + st$
7.  $(a - b)^2$  is equal to  
(a)  $a^2 + b^2 - 2ab$                       (b)  $a^2 - b^2 + 2ab$                       (c)  $a^2 - b^2$                       (d)  $(a - b)(a + b)$
8. Using identity  $a^2 - b^2 = (a + b)(a - b)$ , find  $4^2 - 6^2$   
(a) -20                      (b) 20                      (c) -12                              (d) 12
9. The expression in one variable is  
(a)  $x + x^2 + 1$                       (b)  $x + y$                       (c)  $x + 9y$                               (d)  $xyz$
10.  $(a + b)(a - b)$  is equal to  
(a)  $a^2 - b^2$                       (b)  $a^2 + b^2$                       (c)  $a^2 + b^2 + 2ab$                       (d)  $a^2 + b^2 - 2ab$
11. If  $ab = 6$  and  $a + b = 5$  then the value of  $(a^2 + b^2)$  is  
(a) 11                      (b) 12                      (c) 13                              (d) 16
12. If  $\left(x + \frac{1}{x}\right) = 3$ , then the value of  $\left(x^3 + \frac{1}{x^3}\right)$  is  
(a) 5                      (b) 7                      (c) 9                              (d) 11
13. If  $x + y = 12$  and  $xy = 14$ , then the value of  $(x^2 + y^2)$  is  
(a) 144                      (b) 158                      (c) 116                              (d) none of these
14. If  $x - y = 7$  and  $xy = 9$ , then the value of  $(x^2 + y^2)$  is  
(a) 64                      (b) 67                      (c) 63                              (d) none of these
15. If  $\left(x + \frac{1}{x}\right) = 4$ , then the value of  $\left(x^2 + \frac{1}{x^2}\right)$  is  
(a) 14                      (b) 12                      (c) 16                              (d) none of these

16. If  $\left(x - \frac{1}{x}\right) = 5$ , then the value of  $\left(x^2 + \frac{1}{x^2}\right)$  is  
(a) 25 (b) 27 (c) 29 (d) none of these
17. If  $\left(x - \frac{1}{x}\right) = 5$ , then the value of  $\left(x^4 + \frac{1}{x^4}\right)$  is  
(a) 725 (b) 727 (c) 729 (d) none of these
18. If  $\left(x + \frac{1}{x}\right) = 5$ , then the value of  $\left(x^2 + \frac{1}{x^2}\right)$  is  
(a) 25 (b) 23 (c) 29 (d) none of these
19. If  $\left(x + \frac{1}{x}\right) = 5$ , then the value of  $\left(x^4 + \frac{1}{x^4}\right)$  is  
(a) 525 (b) 527 (c) 529 (d) none of these
20. Find the value of the expression  $(81x^2 + 16y^2 - 72xy)$ , when  $x = \frac{2}{3}$  and  $y = \frac{3}{4}$ .  
(a) 5 (b) 7 (c) 9 (d) 11
- .....

**PRACTICE QUESTIONS**  
**CLASS VIII: CHAPTER - 09**  
**ALGEBRAIC EXPRESSIONS**

1. Identify, in the following expressions, terms which are not constants. Give their numerical coefficients:  $xy + 4$ ,  $13 - y^2$ ,  $13 - y + 5y^2$ ,  $4p^2q - 3pq^2 + 5$
2. (a) What are the coefficients of  $x$  in the following expressions?  $4x - 3y$ ,  $8 - x + y$ ,  $y^2x - y$ ,  $2z - 5xz$   
(b) What are the coefficients of  $y$  in the following expressions?  $4x - 3y$ ,  $8 + yz$ ,  $yz^2 + 5$ ,  $my + m$
3. Classify the following expressions as a monomial, a binomial or a trinomial:  $a$ ,  $a + b$ ,  $ab + a + b$ ,  $ab + a + b - 5$ ,  $xy$ ,  $xy + 5$ ,  $5x^2 - x + 2$ ,  $4pq - 3q + 5p$ ,  $7$ ,  $4m - 7n + 10$ ,  $4mn + 7$ .
4. Collect like terms and simplify the expression:  $12m^2 - 9m + 5m - 4m^2 - 7m + 10$
5. Add and subtract
  - (i)  $m - n$ ,  $m + n$
  - (ii)  $mn + 5 - 2$ ,  $mn + 3$
6. Subtract  $24ab - 10b - 18a$  from  $30ab + 12b + 14a$ .
7. From the sum of  $2y^2 + 3yz$ ,  $-y^2 - yz - z^2$  and  $yz + 2z^2$ , subtract the sum of  $3y^2 - z^2$  and  $-y^2 + yz + z^2$ .
8. Classify the following polynomials as monomials, binomials, trinomials.  
 $-z + 5$ ,  $x + y + z$ ,  $y + z + 100$ ,  $ab - ac$ ,  $17$
9. Add:
  1.  $t - 8tz$ ,  $3tz - z$ ,  $z - t$
  2.  $7mn + 5$ ,  $12mn + 2$ ,  $9mn - 8$ ,  $-2mn - 3$
  3.  $a + b - 3$ ,  $b - a + 3$ ,  $a - b + 3$
  4.  $14x + 10y - 12xy - 13$ ,  $18 - 7x - 10y + 8xy$ ,  $4xy$
  5.  $5m - 7n$ ,  $3n - 4m + 2$ ,  $2m - 3mn - 5$
10. Add:  $7xy + 5yz - 3zx$ ,  $4yz + 9zx - 4y$ ,  $-3xz + 5x - 2xy$ .
11. Subtract  $5x^2 - 4y^2 + 6y - 3$  from  $7x^2 - 4xy + 8y^2 + 5x - 3y$ .
12. Subtract  $4a - 7ab + 3b + 12$  from  $12a - 9ab + 5b - 3$
13. Subtract  $3xy + 5yz - 7zx$  from  $5xy - 2yz - 2zx + 10xyz$
14. Subtract  $4p^2q - 3pq + 5pq^2 - 8p + 7q - 10$  from  $18 - 3p - 11q + 5pq - 2pq^2 + 5p^2q$
15. (a) What should be added to  $x^2 + xy + y^2$  to obtain  $2x^2 + 3xy$ ?  
(b) What should be subtracted from  $2a + 8b + 10$  to get  $-3a + 7b + 16$ ?
16. What should be taken away from  $3x^2 - 4y^2 + 5xy + 20$  to obtain  $-x^2 - y^2 + 6xy + 20$ ?
17. (a) From the sum of  $3x - y + 11$  and  $-y - 11$ , subtract  $3x - y - 11$ .

(b) From the sum of  $4 + 3x$  and  $5 - 4x + 2x^2$ , subtract the sum of  $3x^2 - 5x$  and  $-x^2 + 2x + 5$ .

18. What should be the value of  $a$  if the value of  $2x^2 + x - a$  equals to 5, when  $x = 0$ ?

19. Simplify the expression and find its value when  $a = 5$  and  $b = -3$ .

$$2(a^2 + ab) + 3 - ab$$

20. If  $p = -10$ , find the value of  $p^2 - 2p - 100$

21. Construct

- (a) 3 binomials with only  $x$  as a variable;
- (b) 3 binomials with  $x$  and  $y$  as variables;
- (c) 3 monomials with  $x$  and  $y$  as variables;
- (d) 2 polynomials with 4 or more terms.

22. Find the volume of each rectangular box with given length, breadth and height.

	length	breadth	Height
(i)	$2ax$	$3by$	$5cz$
(ii)	$m^2n$	$n^2p$	$p^2m$
(iii)	$2q$	$4q^2$	$8q^3$

23. Find the product (i)  $2x(3x + 5xy)$  (ii)  $a^2(2ab - 5c)$

24. Simplify the expressions and evaluate them as directed:

(i)  $x(x - 3) + 2$  for  $x = 1$ , (ii)  $3y(2y - 7) - 3(y - 4) - 63$  for  $y = -2$

25. Subtract  $3pq(p - q)$  from  $2pq(p + q)$ .

26. Add

(i)  $5m(3 - m)$  and  $6m^2 - 13m$  (ii)  $4y(3y^2 + 5y - 7)$  and  $2(y^3 - 4y^2 + 5)$

27. Add:  $p(p - q)$ ,  $q(q - r)$  and  $r(r - p)$

28. Add:  $2x(z - x - y)$  and  $2y(z - y - x)$

29. Subtract:  $3l(l - 4m + 5n)$  from  $4l(10n - 3m + 2l)$

30. Subtract:  $3a(a + b + c) - 2b(a - b + c)$  from  $4c(-a + b + c)$

31. Simplify

(i).  $(a + b)(2a - 3b + c) - (2a - 3b)c$ .

(ii).  $(x + y)(2x + y) + (x + 2y)(x - y)$

(iii).  $(a + b + c)(a + b - c)$

32. Multiply the binomials.

(i)  $(2pq + 3q^2)$  and  $(3pq - 2q^2)$

(ii)  $\left(\frac{3}{4}a^2 + 3b^2\right)$  and  $4\left(a^2 - \frac{2}{3}b^2\right)$

(iii)  $(y - 8)$  and  $(3y - 4)$ .

33. Using the formula of  $(a + b)^2$ , find (i)  $(2x + 3y)^2$  (ii)  $103^2$

34. Find the product.

- (i)  $(5 - 2x)(3 + x)$  (ii)  $(x + 7y)(7x - y)$   
(iii)  $(a^2 + b)(a + b^2)$  (iv)  $(p^2 - q^2)(2p + q)$

35. Using the formula of  $(a + b)(a - b)$ , find (i)  $\left(\frac{3}{2}m + \frac{2}{3}n\right)\left(\frac{3}{2}m - \frac{2}{3}n\right)$  (ii)  $983^2 - 17^2$   
(iii)  $194 \times 206$

36. Using the formula of  $(a - b)^2$ , find (i)  $(4p - 3q)^2$  (ii)  $(4.9)^2$

37. Use the Identity  $(x + a)(x + b) = x^2 + (a + b)x + ab$  to find the following:

- (i)  $501 \times 502$  (ii)  $95 \times 103$

38. Show that.

(i)  $\left(\frac{4}{3}m - \frac{3}{4}n\right)^2 + 2mn = \frac{16}{9}m^2 + \frac{9}{16}n^2$

(ii)  $(9p - 5q)^2 + 180pq = (9p + 5q)^2$

(iii)  $(a - b)(a + b) + (b - c)(b + c) + (c - a)(c + a) = 0$

39. Using identities, evaluate.

- (i)  $72^2$  (ii)  $199^2$  (iii)  $103^2$  (iv)  $999^2$  (v)  $5.1^2$   
(vi)  $296 \times 304$  (vii)  $77 \times 83$  (viii)  $9.2^2$  (ix)  $10.5 \times 9.5$

**HOT'S QUESTIONS**  
**CLASS VIII: CHAPTER - 09**  
**ALGEBRAIC EXPRESSIONS**

1. Add  $5x^2 - \frac{1}{3}x + \frac{5}{2}$ ,  $-\frac{1}{2}x^2 + \frac{1}{2}x - \frac{1}{3}$  and  $-2x^2 + \frac{1}{5}x - \frac{1}{6}$ .
2. Add 2,  $\frac{2x}{3} - \frac{5x^2}{3} + \frac{5x^3}{2}$ ,  $-\frac{4}{3} + \frac{2x^2}{3} - \frac{x}{2}$  and  $\frac{5x^3}{3} + 3x^2 + 3x + \frac{6}{5}$ .
3. Add  $\frac{7}{2}x^3 - \frac{1}{2}x^2 + \frac{5}{3}$ ,  $\frac{3}{2}x^3 + \frac{7}{4}x^2 - x + \frac{1}{3}$  and  $\frac{3}{2}x^2 - \frac{5}{2}x - 2$ .
4. Subtract  $-2x^2 + \frac{1}{2}x - 3$  from  $7x^2 - 2x + 10$ .
5. Subtract  $\frac{3}{2}x^2y + \frac{4}{5}y - \frac{1}{3}x^2yz$  from  $\frac{12}{5}x^2yz - \frac{3}{5}xyz + \frac{2}{3}x^2y$ .
6. Subtract  $x^2y - \frac{4}{5}xy^2 + \frac{4}{3}xy$  from  $\frac{2}{3}x^2y + \frac{3}{2}xy^2 - \frac{1}{3}xy$ .
7. Take away  $\frac{6}{5}x^2 - \frac{4}{5}x^3 + \frac{5}{6} + \frac{3}{2}x$  from  $\frac{x^3}{3} - \frac{5}{2}x^2 + \frac{3}{5}x + \frac{1}{4}$ .
8. Take away  $\frac{7}{4}x^3 + \frac{3}{5}x^2 + \frac{1}{2}x + \frac{9}{2}$  from  $\frac{7}{2} - \frac{x}{3} - \frac{x^2}{5}$ .
9. Take away  $\frac{5a^2}{2} + \frac{3a^3}{2} + \frac{a}{3} - \frac{6}{5}$  from  $\frac{1}{3}a^3 - \frac{3}{4}a^2 - \frac{5}{2}$ .
10. Take away  $\frac{2}{3}ac - \frac{5}{7}ab + \frac{2}{3}bc$  from  $\frac{3}{2}ab - \frac{7}{4}ac - \frac{5}{6}bc$ .
11. Take away  $\frac{x^3}{3} + \frac{7}{2}x^2 + \frac{1}{2}x + \frac{1}{2}$  from  $\frac{1}{3} - \frac{5}{3}x^2$ .
12. Simplify:  $-\frac{1}{2}a^2b^2c^2 + \frac{1}{3}ab^2c - \frac{1}{4}abc^2 - \frac{1}{5}cb^2a^2 + \frac{1}{6}cb^2a - \frac{1}{7}c^2ab + \frac{1}{8}ca^2b$ .
13. Simplify:  $\left(\frac{1}{3}x^2 - \frac{4}{7}x + 11\right) - \left(\frac{1}{7}x - 3 - 2x^2\right) - \left(\frac{2}{7}x - \frac{2}{3}x^2 + 2\right)$ .
14. Simplify:  $\frac{11}{2}x^2y - \frac{9}{4}xy^2 + \frac{1}{4}xy - \frac{1}{14}y^2x + \frac{1}{15}yx^2 + \frac{1}{2}xy$ .
15. Simplify:  $15a^2 - 6a(a - 2) + a(3 + 7a)$ .
16. Simplify:  $x^2(1 - 3y^2) + x(xy^2 - 2x) - 3y(y - 4x^2y)$ .
17. Simplify:  $4xy(x - y) - 6x^2(y - y^2) - 3y^2(2x^2 - x) + 2xy(x - y)$ .
18. Simplify:  $\frac{3}{2}x^2(x^2 - 1) + \frac{1}{4}x^2(x^2 + x) - \frac{3}{4}x(x^3 - 1)$ .
19. Simplify:  $x^2y(x - y^2) + xy^2(4xy - 2x^2) - x^3y(1 - 2y)$ .
20. Simplify:  $x^2y(x^3 - x + 1) - xy(x^4 - 2x^2 + 2x) - y(x^3 - x^2 - 1)$ .
21. Find the product of  $\left(x + \frac{2}{7}x^2\right)$  and  $(7x - x^2)$  and verify the result for  $x = 3$ .
22. Simplify:  $(3x - 2)(x - 1)(3x + 5)$ .

23. Simplify:  $(x^3 - 2x^2 + 3x - 4)(x - 1) - (2x - 3)(x^2 - x + 1)$ .
24. Simplify:  $(x^2 - 3x + 2)(5x - 2) - (3x^2 + 4x - 5)(2x - 1)$ .
25. Simplify:  $(5 - x)(3 - 2x)(4 - 3x)$ .
26. If  $x + y = 12$  and  $xy = 14$ , find the value of  $x^2 + y^2$ .
27. If  $x - y = 8$  and  $xy = 12$ , find the value of  $x^2 + y^2$ .
28. If  $3x + 2y = 12$  and  $xy = 6$ , find the value of  $9x^2 + 4y^2$ .
29. If  $4x^2 + y^2 = 40$  and  $xy = 6$ , find the value of  $2x + y$  and  $2x - y$ .
30. Find the product:  $\left(x - \frac{1}{x}\right)\left(x + \frac{1}{x}\right)\left(x^2 + \frac{1}{x^2}\right)\left(x^4 + \frac{1}{x^4}\right)$
31. Simplify:  $(x^2 + x + 1)(x^2 - x + 1)$
32. Prove that:  $2a^2 + 2b^2 + 2c^2 - 2ab - 2bc - 2ca = (a - b)^2 + (b - c)^2 + (c - a)^2$
33. If  $a^2 + b^2 + c^2 - ab - bc - ca = 0$ , prove that  $a = b = c$ .
34. If  $\left(x + \frac{1}{x}\right) = 5$ , then the value of (i)  $\left(x^2 + \frac{1}{x^2}\right)$  and (ii)  $\left(x^4 + \frac{1}{x^4}\right)$ .
35. If  $\left(x - \frac{1}{x}\right) = 5$ , then the value of (i)  $\left(x^2 + \frac{1}{x^2}\right)$  and (ii)  $\left(x^4 + \frac{1}{x^4}\right)$ .
36. If  $\left(x + \frac{1}{x}\right) = 6$ , then the value of (i)  $\left(x^2 + \frac{1}{x^2}\right)$  and (ii)  $\left(x^4 + \frac{1}{x^4}\right)$ .
37. If  $\left(x + \frac{1}{x}\right) = 4$ , then the value of (i)  $\left(x^2 + \frac{1}{x^2}\right)$  and (ii)  $\left(x^4 + \frac{1}{x^4}\right)$ .
38. If  $\left(x - \frac{1}{x}\right) = 6$ , then the value of (i)  $\left(x^2 + \frac{1}{x^2}\right)$  and (ii)  $\left(x^4 + \frac{1}{x^4}\right)$ .
39. If  $\left(x - \frac{1}{x}\right) = 4$ , then the value of (i)  $\left(x^2 + \frac{1}{x^2}\right)$  and (ii)  $\left(x^4 + \frac{1}{x^4}\right)$ .
40. If  $\left(x - \frac{1}{x}\right) = 9$ , then the value of (i)  $\left(x^2 + \frac{1}{x^2}\right)$  and (ii)  $\left(x^4 + \frac{1}{x^4}\right)$ .
41. If  $\left(x + \frac{1}{x}\right) = 9$  and  $\left(x^2 + \frac{1}{x^2}\right) = 53$ , then find the value of  $\left(x - \frac{1}{x}\right)$
42. If  $\left(x^2 + \frac{1}{x^2}\right) = 27$ , then find the value of  $\left(x - \frac{1}{x}\right)$  and  $\left(x + \frac{1}{x}\right)$ .



43. If  $\left(x^2 + \frac{1}{x^2}\right) = 18$ , then find the value of  $\left(x - \frac{1}{x}\right)$  and  $\left(x + \frac{1}{x}\right)$
44. If  $\left(x + \frac{1}{x}\right) = 20$ , then the value of (i)  $\left(x^2 + \frac{1}{x^2}\right)$  and (ii)  $\left(x^4 + \frac{1}{x^4}\right)$ .
45. If  $\left(x - \frac{1}{x}\right) = 3$ , then the value of (i)  $\left(x^2 + \frac{1}{x^2}\right)$  and (ii)  $\left(x^4 + \frac{1}{x^4}\right)$ .
46. If  $\left(x + \frac{1}{x}\right) = 9$ , then the value of (i)  $\left(x^2 + \frac{1}{x^2}\right)$  and (ii)  $\left(x^4 + \frac{1}{x^4}\right)$ .
47. If  $\left(x + \frac{1}{x}\right) = 12$ , then find the value of  $\left(x - \frac{1}{x}\right)$ .
48. What must be added to  $9x^2 - 24x + 10$  to make it a perfect square?
49. If  $x^2 + y^2 = 29$  and  $xy = 2$ , find the value of (i)  $x + y$  (ii)  $x - y$  (iii)  $x^4 + y^4$ .
50. If  $2x + 3y = 14$  and  $2x - 3y = 2$ , find the value of  $xy$ .
- .....

**MCQ WORKSHEET-I**  
**CLASS VIII: CHAPTER - 10**  
**VISUALIZING SOLID SHAPES**

1. Two cubes of dimensions 2 cm x 2 cm x 2 cm are placed side by side, the length of resulting Cuboid is-  
(a) 2 cm                      (b) 3 cm                      (c) 4 cm                      (d) 6 cm
2. The vertical cut of a brick will show the cross section is –  
(a) Rectangle                (b) Pentagon                (c) Triangle                (d) None
3. Cuboid is an example of –  
(a) 2-D Shape                (b) 3-D Shape                (c) Both (a) & (b)                (d) None
4. Which one is a 3D shape?  
(a) Rectangle                (b) circle                      (c) cube                      (d) square
5. A cuboid has \_\_\_\_\_ rectangular faces.  
(a) 4                              (b) 6                              (c) 8                              (d) 12
6. A cuboid has \_\_\_\_\_ edges.  
(a) 4                              (b) 6                              (c) 8                              (d) 12
7. A cuboid has \_\_\_\_\_ vertices.  
(a) 4                              (b) 6                              (c) 8                              (d) 12
8. The number of faces of a cylinder is \_\_\_\_\_.  
(a) 1                              (b) 6                              (c) 2                              (d) 3
9. The number of faces of a cube is \_\_\_\_\_.  
(a) 1                              (b) 6                              (c) 2                              (d) 3
10. The number of faces of a cone is \_\_\_\_\_.  
(a) 1                              (b) 6                              (c) 2                              (d) 3
11. The number of faces of a sphere is \_\_\_\_\_.  
(a) 1                              (b) 6                              (c) 2                              (d) 3
12. The number of vertices of a cube is \_\_\_\_\_.  
(a) 4                              (b) 6                              (c) 8                              (d) 12
13. The number of vertices of a cone is \_\_\_\_\_.  
(a) 1                              (b) 6                              (c) 2                              (d) 3
14. The number of faces of a triangular prism is \_\_\_\_\_.  
(a) 4                              (b) 5                              (c) 6                              (d) none of these
15. The number of faces of a square pyramid is \_\_\_\_\_.  
(a) 4                              (b) 5                              (c) 6                              (d) none of these

**MCQ WORKSHEET-II**  
**CLASS VIII: CHAPTER - 10**  
**VISUALIZING SOLID SHAPES**

1. The number of faces of a triangular pyramid or tetrahedron is \_\_\_\_\_.  
(a) 4                      (b) 5                      (c) 6                      (d) none of these
2. The number of triangular faces of a triangular prism is \_\_\_\_\_.  
(a) 1                      (b) 4                      (c) 2                      (d) 3
3. The number of rectangular faces of a triangular prism is \_\_\_\_\_.  
(a) 1                      (b) 4                      (c) 2                      (d) 3
4. The number of triangular faces of a rectangular pyramid is \_\_\_\_\_.  
(a) 1                      (b) 4                      (c) 2                      (d) 3
5. The number of rectangular faces of a rectangular pyramid is \_\_\_\_\_.  
(a) 1                      (b) 4                      (c) 2                      (d) 3
6. The number of edges of a triangular prism is \_\_\_\_\_.  
(a) 6                      (b) 8                      (c) 9                      (d) 12
7. The number of edges of a square pyramid is \_\_\_\_\_.  
(a) 6                      (b) 8                      (c) 9                      (d) 12
8. The number of edges of a triangular pyramid is \_\_\_\_\_.  
(a) 6                      (b) 8                      (c) 9                      (d) 12
9. The number of edges of a rectangular pyramid is \_\_\_\_\_.  
(a) 6                      (b) 8                      (c) 9                      (d) 12
10. The number of faces of a triangular prism is \_\_\_\_\_.  
(a) 6                      (b) 8                      (c) 4                      (d) 5
11. The number of faces of a triangular pyramid is \_\_\_\_\_.  
(a) 6                      (b) 8                      (c) 4                      (d) 5
12. The number of faces of a square pyramid is \_\_\_\_\_.  
(a) 6                      (b) 8                      (c) 4                      (d) 5
13. The number of faces of a rectangular prism is \_\_\_\_\_.  
(a) 6                      (b) 8                      (c) 4                      (d) 5
14. The corners of a solid shape are called its \_\_\_\_\_.  
(a) vertices              (b) edges              (c) faces              (d) net
15. A \_\_\_\_\_ is a skeleton-outline of a solid that can be folded to make it  
(a) vertices              (b) edges              (c) faces              (d) net

**MCQ WORKSHEET-III**  
**CLASS VIII: CHAPTER - 10**  
**VISUALIZING SOLID SHAPES**

1. What will be the number of faces if there are 6 vertices and 12 edges?  
(a) 8                      b)10                      c)12                      d) 18
2. What will be the number of edges if there are 12 vertices and 20 faces?  
(a) 32                      b)28                      c)30                      d)42
3. Which of the following is Euler's Formula:  
(a)  $F + V - E = 2$                       (b)  $F + V = E - 2$                       (c)  $F - V = E - 2$                       (d)  $F - V + E = 2$

4. Name of the solid given below left figure.  
(a) Cylinder                      b) Cone



- c) Sphere                      d) Cuboid

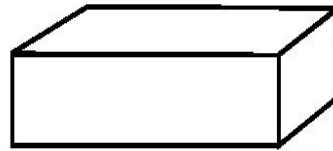

5. Name of the solid given above sided right figure.  
(a) Cylinder                      b) Cone                      c) Sphere                      d) Cuboid
6. Name of the solid given below left figure.  
(a) Cylinder                      b) Cone                      c) Sphere                      d) Cuboid

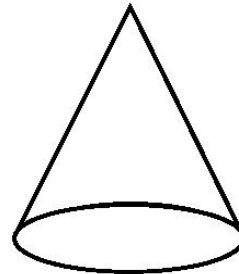
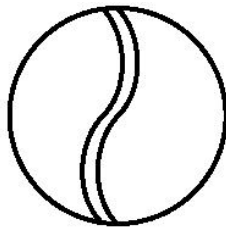

7. Name of the solid given above sided right figure.  
(a) Cylinder                      b) Cone                      c) Sphere                      d) Cuboid
8. Name of the solid given below left figure.  
(a) Pyramid                      b) Cone                      c) Cube                      d) Cuboid

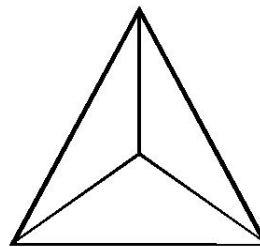
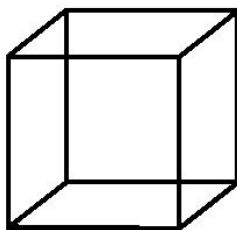

9. Name of the solid given above sided right figure.  
(a) Pyramid                      b) Cone                      c) Cube                      d) Cuboid

10. Name of the solid whose net diagram is given in below left figure.

(a) Pyramid

b) Cone

c) Cube

d) Cuboid

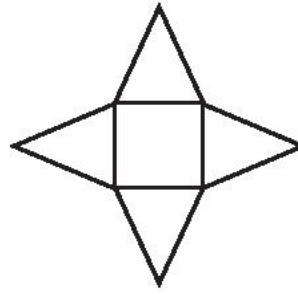
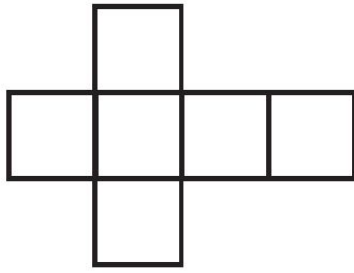

11. Name of the solid whose net diagram is given in above sided right figure.

(a) Pyramid

b) Cone

c) Cube

d) Cuboid

12. Name of the solid whose net diagram is given in below left figure.

(a) Cylinder

b) Cone

c) Sphere

d) Cuboid



13. Name of the solid whose net diagram is given in above sided right figure.

(a) Cylinder

b) Cone

c) Sphere

d) Cuboid

14. Two dice are placed side by side with 5 + 6, what is the total on the face opposite to the given numbers

(a) 3

b) 7

c) 11

d) 6

15. Two dice are placed side by side with 4 + 3, what is the total on the face opposite to the given numbers

(a) 3

b) 7

c) 11

d) 6

**MCQ WORKSHEET-IV**  
**CLASS VIII: CHAPTER - 10**  
**VISUALIZING SOLID SHAPES**

1. Two dice are placed side by side with 2 + 1, what is the total on the face opposite to the given numbers  
(a) 3                                      b) 7                                      c) 11                                      d) 6
2. Two dice are placed side by side with 6 + 2, what is the total on the face opposite to the given numbers  
(a) 3                                      b) 7                                      c) 11                                      d) 6
3. Two dice are placed side by side with 5 + 2, what is the total on the face opposite to the given numbers  
(a) 3                                      b) 7                                      c) 11                                      d) 6
4. What cross-sections do you get when you give a vertical cut to the brick?  
(a) rectangle                              b) square                              c) circle                              d) triangle
5. What cross-sections do you get when you give a vertical cut to the round apple?  
(a) rectangle                              b) square                              c) circle                              d) triangle
6. What cross-sections do you get when you give a vertical cut to a die?  
(a) rectangle                              b) square                              c) circle                              d) triangle
7. What cross-sections do you get when you give a vertical cut to the circular pipe?  
(a) rectangle                              b) square                              c) circle                              d) triangle
8. What cross-sections do you get when you give a vertical cut to an ice-cream cone?  
(a) rectangle                              b) square                              c) circle                              d) triangle
9. What cross-sections do you get when you give a horizontal cut to the brick?  
(a) rectangle                              b) square                              c) circle                              d) triangle
10. What cross-sections do you get when you give a horizontal cut to the round apple?  
(a) rectangle                              b) square                              c) circle                              d) triangle
11. What cross-sections do you get when you give a horizontal cut to a die?  
(a) rectangle                              b) square                              c) circle                              d) triangle
12. What cross-sections do you get when you give a horizontal cut to the circular pipe?  
(a) rectangle                              b) square                              c) circle                              d) triangle
13. What cross-sections do you get when you give a horizontal cut to an ice-cream cone?  
(a) rectangle                              b) square                              c) circle                              d) triangle
14. What cross-sections do you get when you give a horizontal cut to cricket ball?  
(a) rectangle                              b) square                              c) circle                              d) triangle
15. What cross-sections do you get when you give a vertical cut to cylindrical base?  
(a) rectangle                              b) square                              c) circle                              d) triangle

**PRACTICE QUESTIONS**  
**CLASS VIII: CHAPTER - 10**  
**VISUALIZING SOLID SHAPES**

1. Match the shape with the name:

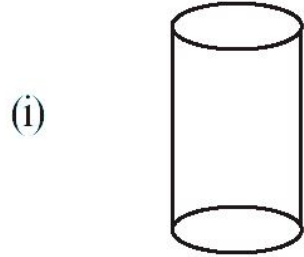

(a) Cuboid

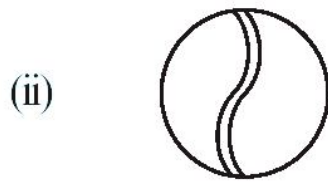

(b) Cylinder



(c) Cube

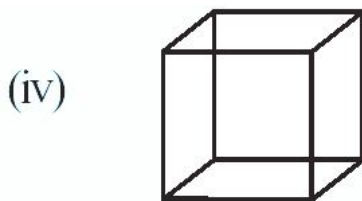

(d) Sphere

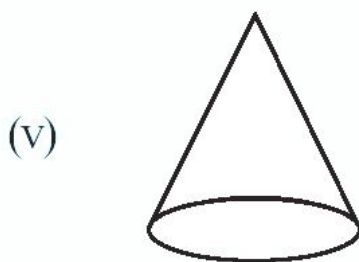

(e) Pyramid

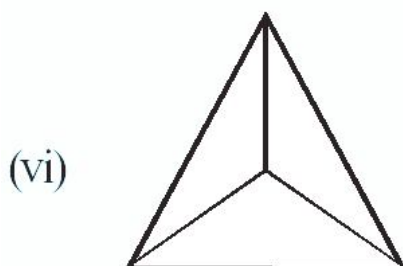

(f) Cone

2. Can this be a net for a die? Explain your answer.

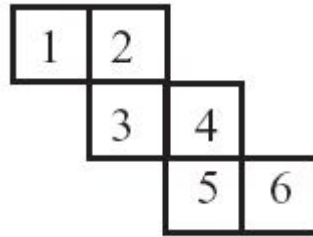

3. The dimensions of a cuboid are 5 cm, 3 cm and 2 cm. Draw three different isometric sketches of this cuboid.
4. Three cubes each with 2 cm edge are placed side by side to form a cuboid. Sketch an oblique or isometric sketch of this cuboid.
5. If two cubes of dimensions 2 cm by 2cm by 2cm are placed side by side, what would the dimensions of the resulting cuboid be?
6. Two dice are placed side by side as shown: Can you say what the total would be on the face opposite to (a) 5 + 6 (b) 4 + 3 (Remember that in a die sum of numbers on opposite faces is 7)
7. What cross-sections do you get when you give a (i) vertical cut (ii) horizontal cut to the following solids? (a) A brick (b) A round apple (c) A die (d) A circular pipe (e) An ice cream cone
8. For given solid, draw the top view, front view and side view.

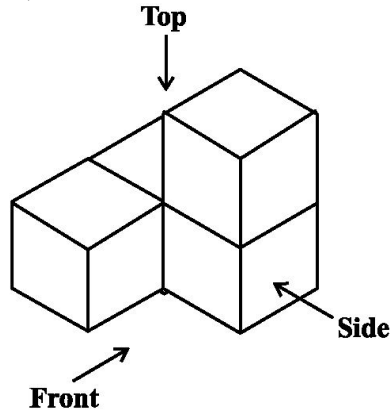

9. For given solid, draw the top view, front view and side view.

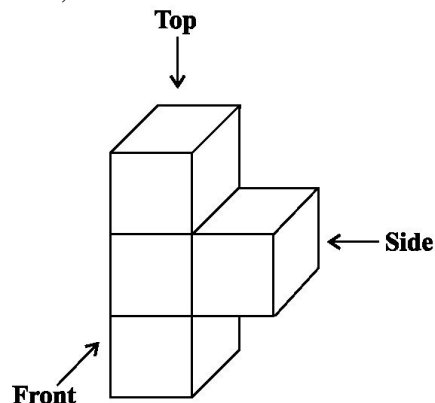



10. For given solid, draw the top view, front view and side view.

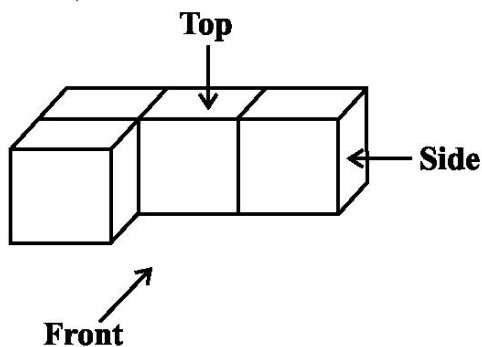

11. For given solid, draw the top view, front view and side view.

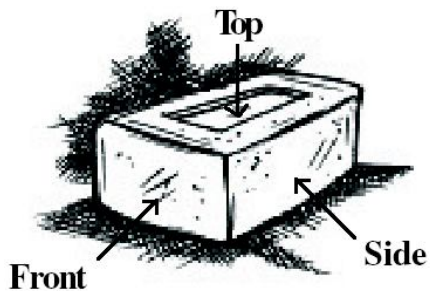

A brick

12. For given solid, draw the top view, front view and side view.

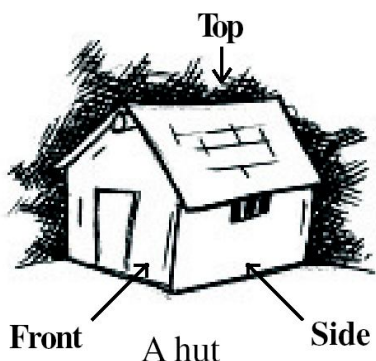

A hut

13. Is it possible to have a polyhedron with any given number of faces?

14. Draw the front view, side view and top view of the given objects.

A military tent

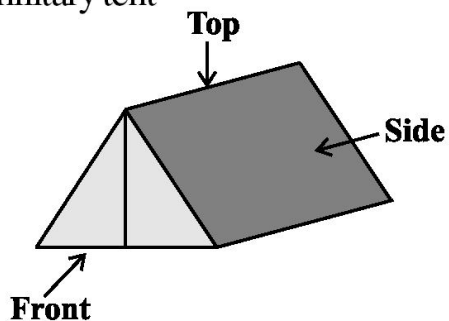

15. How are prisms and cylinders alike?

16. How are pyramids and cones alike?

17. Is a square prism same as a cube? Explain.
18. Can a polyhedron have 10 faces, 20 edges and 15 vertices?
19. Draw the front view, side view and top view of the given objects.

A hexagonal block

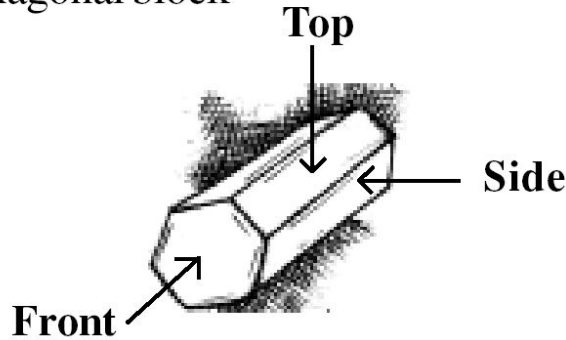

20. Draw the front view, side view and top view of the given objects.

A dice

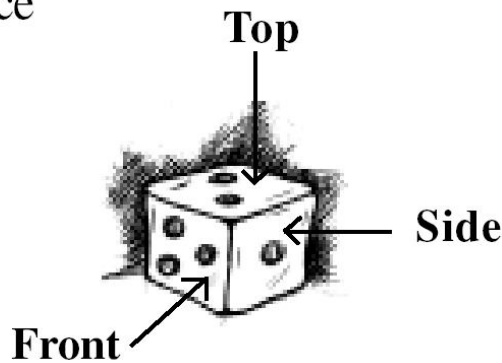

21. Draw the front view, side view and top view of the given objects.

A solid

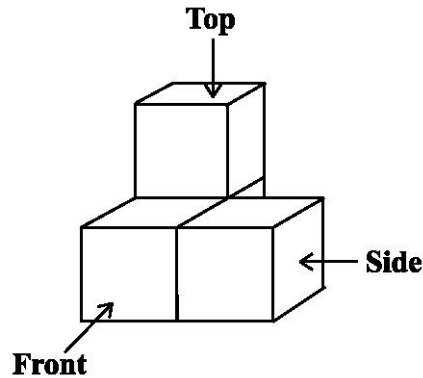

22. Using Euler's formula find the unknown.



<b>Faces</b>	?	5	20
<b>Vertices</b>	6	?	12
<b>Edges</b>	12	9	?

23. Tabulate the number of faces, edges and vertices for the following polyhedrons: (Here 'V' stands for number of vertices, 'F' stands for number of faces and 'E' stands for number of edges).

<b>Solid</b>	<b>F</b>	<b>V</b>	<b>E</b>	<b>F + V</b>	<b>E + 2</b>
Cuboid					
Triangular Pyramid					
Triangular Prism					
Pyramid with square base					
Prism with square base					

24. Draw a figure for the following solid
- A cone surmounted on a cylinder
  - A cylindrical shell
  - A cone surmounted by a hemisphere
  - A rectangular path
  - A hemispherical shell
  - Cylinder surmounted by a hemisphere

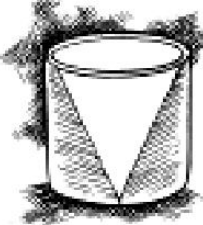
25. Match the following pictures (objects) with their shapes:

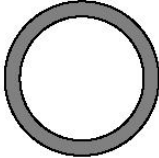
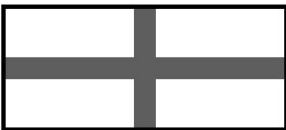
Picture (object)	Shape
(i) An agricultural field 	Two rectangular cross paths inside a rectangular park.
(ii) A groove 	A circular path around a circular ground.
(iii) A toy 	A triangular field adjoining a square field.
(iv) A circular park 	A cone taken out of a cylinder.
(v) A cross path 	A hemisphere surmounted on a cone.

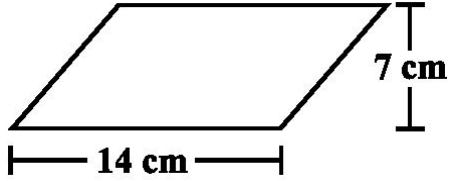

**MCQ WORKSHEET-I**  
**CLASS VIII: CHAPTER - 11**  
**MENSURATION**

1.  $\Delta ABC$  is isosceles in which  $AE \perp BC$ ,  $AE = 6$  cm ,  $BC = 9$  cm, the area of  $\Delta ABC$  is  
 (a)  $27$  cm<sup>2</sup>                      (b)  $54$  cm<sup>2</sup>                      (c)  $22.5$  cm<sup>2</sup>                      (d)  $45$  cm<sup>2</sup>
  2. The area of parallelogram is  
 (a) base + height                      (b) base x height                      (c) base x base                      (d) height x height
  3. The base in the area of parallelogram is  
 (a)  $\frac{area}{height}$                       (b)  $\frac{height}{area}$                       (c) area x base                      (d) area x height
  4. The height in the area of parallelogram is  
 (a)  $\frac{area}{base}$                       (b)  $\frac{base}{area}$                       (c) area x base                      (d) area x height
  5. Which of the following has the formula : Base x Height  
 (a) area of parallelogram                      (b) area of quadrilateral  
 (c) area of triangle                      (d) area of trapezium
  6. The area of triangle is  
 (a) base x height                      (b)  $\frac{1}{2}$  x base x height                      (c)  $\frac{1}{2}$  x (base + height)                      (d) base + height
  7. The height in the area of a triangle  
 (a)  $\frac{2 \cdot area}{base}$                       (b)  $\frac{2 \cdot base}{area}$                       (c)  $\frac{base}{2 \cdot area}$                       (d)  $\frac{area}{2 \cdot base}$
  8. The area of the given parallelogram in the below left figure is  
 (a)  $98$  cm<sup>2</sup>                      (b)  $77$  cm<sup>2</sup>                      (c)  $49$  cm<sup>2</sup>                      (d) none of these
- 

14 cm  
7 cm

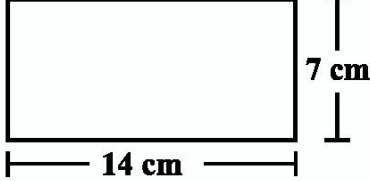

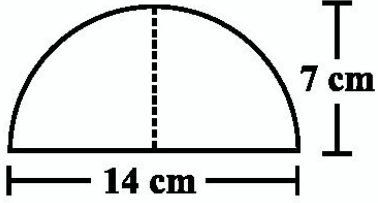
14 cm  
7 cm
9. The area of the given rectangle in the above sided right figure is  
 (a)  $98$  cm<sup>2</sup>                      (b)  $77$  cm<sup>2</sup>                      (c)  $49$  cm<sup>2</sup>                      (d) none of these
  10. The area of the given parallelogram in the below left figure is  
 (a)  $98$  cm<sup>2</sup>                      (b)  $77$  cm<sup>2</sup>                      (c)  $49$  cm<sup>2</sup>                      (d) none of these
- 

14 cm  
7 cm

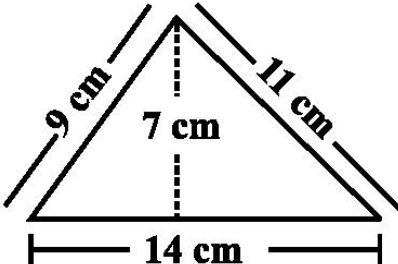

9 cm  
7 cm  
11 cm  
14 cm
11. The area of the given triangle in the above sided right figure is  
 (a)  $98$  cm<sup>2</sup>                      (b)  $77$  cm<sup>2</sup>                      (c)  $49$  cm<sup>2</sup>                      (d) none of these

12. The area of the given square in the below left figure is  
 (a)  $98 \text{ cm}^2$  (b)  $77 \text{ cm}^2$  (c)  $49 \text{ cm}^2$  (d) none of these

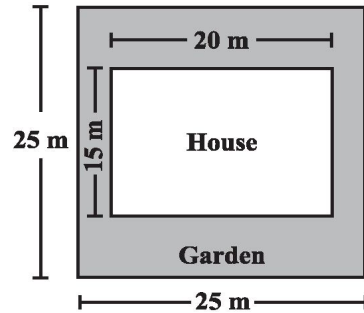
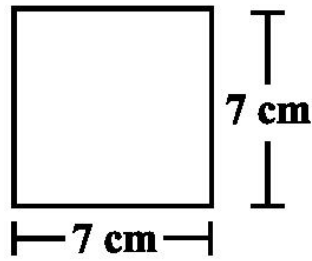

13. The area of the garden (shaded portion) in the above sided right figure is  
 (a)  $300 \text{ m}^2$  (b)  $625 \text{ m}^2$  (c)  $325 \text{ m}^2$  (d) none of these

14. The perimeter of the below left figure is  
 (a) 11.6 cm (b) 14.6 cm (c) 12.8 cm (d) none of these

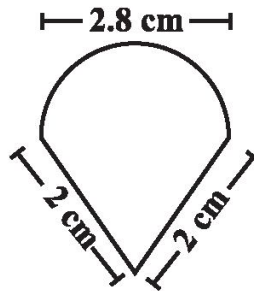
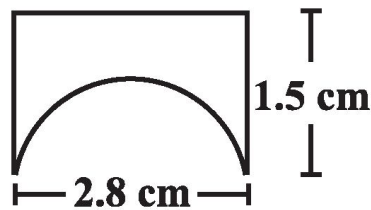

15. The perimeter of the above sided right figure is  
 (a) 11.6 cm (b) 14.6 cm (c) 12.8 cm (d) none of these

16. The perimeter of the below left figure is  
 (a) 11.6 cm (b) 14.6 cm (c) 12.8 cm (d) none of these

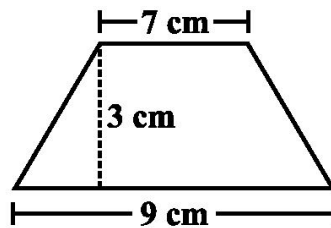
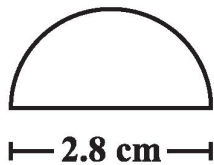

17. The area of the above sided right figure is  
 (a)  $24 \text{ cm}^2$  (b)  $48 \text{ cm}^2$  (c)  $49 \text{ cm}^2$  (d) none of these

**MCQ WORKSHEET-II**  
**CLASS VIII: CHAPTER - 11**  
**MENSURATION**

1. What will be the area of circular button of radius 7 cm  
(a)  $154 \text{ cm}^2$       (b)  $49 \text{ cm}^2$       (c)  $154 \text{ cm}$       (d)  $3.14 \times 7 \text{ cm}^2$
2. The circumference of circle whose diameter is 14 cm will be  
(a) 44 cm      (b) 88 cm      (c)  $44 \text{ cm}^2$       (d)  $88 \text{ cm}^2$
3. The perimeter of circle is its  
(a) area      (b) circumference      (c) radius      (d) diameter
4. Diameter is \_\_\_\_\_ .  
(a) twice radius      (b) half radius      (c) equal to radius      (d) one-third of radius
5.  $\pi$  (pi) is  
(a) ratio of circumference to diameter      (b) diameter to circumference  
(c)  $21/17$       (d) 3.41
6. If the area of circle is  $44 \text{ cm}^2$ , the perimeter will be  
(a)  $11 \text{ cm}^2$       (b) 11 cm  
(c)  $22 \text{ cm}^2$       (d) none of these
7. If the radius of pipe is 1 cm, the circumference of pipe will be  
(a) 62.8 cm      (b) 6.28 cm      (c)  $62.8 \text{ cm}^2$       (d) 6.28 cm
8. The circumference of a circle is  
(a)  $\pi r$       (b)  $\pi r^2$       (c)  $\pi \times 2r$       (d)  $\pi + 2r$
9. The diameter of a circle is  
(a)  $r^2$       (b)  $2r$       (c)  $2\pi r^3$       (d)  $\pi r^2$
10. Which of the following is an example of circle?  
(a) a chair      (b) a bottle cap      (c) a cup      (d) a table
11. The area of a circle is  
(a)  $2 \pi r$       (b)  $2\pi r^2$       (c)  $\pi r^2$       (d)  $\pi d$
12.  $1 \text{ m}^2 = \underline{\hspace{2cm}}$  .  
(a)  $100 \text{ cm}^2$       (b)  $1000 \text{ cm}^2$       (c)  $10000 \text{ m}^2$       (d)  $10000 \text{ cm}^2$
13. One hectare is equal to  
(a)  $100 \text{ m}^2$       (b)  $1000 \text{ m}^2$       (c)  $10,000 \text{ m}^2$       (d) 10,000 m
14. The circumference of a circle with radius 7 cm is  
(a) 11 cm      (b) 22 cm      (c) 44 cm      (d) 49 cm
15. The area of a circle is  $49\pi \text{ cm}^2$ . Its circumference is  
(a)  $7\pi \text{ cm}$       (b)  $14\pi \text{ cm}$       (c)  $21\pi \text{ cm}$       (d)  $28\pi \text{ cm}$

**MCQ WORKSHEET-III**  
**CLASS VIII: CHAPTER - 11**  
**MENSURATION**

1. The perimeter of circular field is 242cm. The area of the field is  
(a)  $9317 \text{ cm}^2$  (b)  $18634 \text{ cm}^2$  (c)  $4658.5 \text{ cm}^2$  (d) none of these
2. The area of a circle is  $38.5 \text{ cm}^2$ . Its circumference is  
(a) 62 cm (b) 12.1 cm (c) 11 cm (d) 22 cm
3. The difference between the circumference and radius of a circle is 37 cm. The area of the circle is  
(a)  $111 \text{ cm}^2$  (b)  $184 \text{ cm}^2$  (c)  $154 \text{ cm}^2$  (d)  $259 \text{ cm}^2$
4. The circumference of two circles are in the ratio 2 : 3. The ratio of their areas is  
(a) 2 : 3 (b) 4 : 9 (c) 9 : 4 (d) none of these
5. On increasing the diameter of circle by 40%, its area will be increased by  
(a) 40% (b) 80% (c) 96% (d) none of these
6. In making 1000 revolutions, a wheel covers 88 km. The diameter of the wheel is  
(a) 14 m (b) 24 m (c) 28 m (d) 40 m
7. The diameter of a wheel is 40 cm. How many revolutions will it make an covering 176 m?  
(a) 140 (b) 150 (c) 160 (d) 166
8. The radius of wheel is 0.25 m. How many revolutions will it make in covering 11 km?  
(a) 2800 (b) 4000 (c) 5500 (d) 7000
9. Find the circumference of a circle of diameter 21 cm.  
(a) 62 cm (b) 64 cm (c) 66 cm (d) 68 cm
10. Find the area of a circle whose circumference is 52.8 cm.  
(a)  $221.76 \text{ cm}^2$  (b)  $220.76 \text{ cm}^2$  (c)  $200.76 \text{ cm}^2$  (d) none of these.
11. A steel wire when bent in the form of a square, encloses an area of 121 sq. cm. The same wire is bent in the form of a circle. Find the area of the circle.  
(a)  $111 \text{ cm}^2$  (b)  $184 \text{ cm}^2$  (c)  $154 \text{ cm}^2$  (d)  $259 \text{ cm}^2$
12. If the perimeter of a semicircular protractor is 36 cm, find the diameter.  
(a) 14 cm (b) 16 cm (c) 18 cm (d) 12 cm
13. The area of a square and a rectangle are equal. If the side of the square is 40 cm and the breadth of the rectangle is 25 cm, find the length of the rectangle.  
(a) 60 cm (b) 62 cm (c) 64 cm (d) 68 cm

**MCQ WORKSHEET-IV**  
**CLASS VIII: CHAPTER - 11**  
**MENSURATION**

1. The surface area of a cuboid is  
(a)  $2(lb + bh + lh)$     (b)  $3(lb + bh + lh)$     (c)  $2(lb - bh - lh)$     (d)  $3(lb - bh - lh)$
2. The surface area of a cube if edge 'a' is  
(a)  $7a^2$     (b)  $6a^2$     (c)  $5a^3$     (d)  $5a^2$
3. The length, breadth and height of a room is 5m, 4m and 3m. The cost of white washing its four walls at the rate of Rs. 7.50 per  $m^2$  is  
(a) Rs. 110    (b) Rs. 109    (c) Rs. 220    (d) Rs. 105
4. The perimeter of floor of rectangular hall is 250m. The cost of the white washing its four walls is Rs. 15000. The height of the room is  
(a) 5m    (b) 4m    (c) 6m    (d) 8m
5. The breadth of a room is twice its height and is half of its length. The volume of room is  $512dm^3$ . Its dimensions are  
(a) 16 dm, 8 dm, 4 dm    (b) 12 dm, 8 dm, 2 dm  
(c) 8 dm, 4 dm, 2 dm    (d) 10 dm, 15 dm, 20 dm
6. The area of three adjacent faces of a cube is x, y and z. Its volume V is  
(a)  $V = xyz$     (b)  $V^3 = xyz$     (c)  $V^2 = xyz$     (d) none of these
7. Two cubes each of edge 12 cm are joined. The surface area of new cuboid is  
(a)  $140 cm^2$     (b)  $1440 cm^2$     (c)  $144 cm^2$     (d)  $72 cm^2$
8. The curved surface area of cylinder of height 'h' and base radius 'r' is  
(a)  $2\pi rh$     (b)  $\pi rh$     (c)  $\frac{1}{2}\pi rh$     (d) none of these
9. The total surface area of cylinder of base radius 'r' and height 'h' is  
(a)  $2\pi(r + h)$     (b)  $2\pi r(r + h)$     (c)  $3\pi r(r + h)$     (d)  $4\pi r(r + h)$
10. The curved surface area of a cylinder of height 14 cm is  $88 cm^2$ . The diameter of its circular base is  
(a) 5cm    (b) 4cm    (c) 3cm    (d) 2cm
11. It is required to make a closed cylindrical tank of height 1 m and base diameter 140cm from a metal sheet. How many square meters a sheet are required for the same?  
(a)  $6.45m^2$     (b)  $6.48m^2$     (c)  $7.48m^2$     (d)  $5.48m^2$ .
12. A metal pipe is 77 cm long. Inner diameter of cross section is 4 cm and outer diameter is 4.4 cm. Its inner curved surface area is:  
(a)  $864 cm^2$     (b)  $968 cm^2$     (c)  $768 cm^2$     (d) none of these



**MCQ WORKSHEET-V**  
**CLASS VIII: CHAPTER - 11**  
**MENSURATION**

- The diameter of a roller is 84 cm and its length is 120 cm. It takes 500 complete revolutions to move once over to level a playground. The area of the playground in  $m^2$  is:  
(a) 1584      (b) 1284      (c) 1384      (d) 1184
- A cylindrical pillar is 50 cm in diameter and 3.5 m in height. The cost of painting its curved surface at the rate of Rs. 12.50 per  $m^2$  is:  
(a) Rs. 68.75   (b) Rs. 58.75   (c) Rs. 48.75   (d) Rs. 38.75
- The inner diameter of circular well is 3.5m. It is 10m deep. Its inner curved surface area in  $m^2$  is:  
(a) 120      (b) 110      (c) 130      (d) 140
- In a hot water heating system there is a cylindrical pipe of length 28 m and diameter 5 cm. The total radiating surface area in the system in  $m^2$  is:  
(a) 6.6      (b) 5.5      (c) 4.4      (d) 3.4
- A matchbox measures 4 cm x 2.5 cm x 1.5 cm. The volume of packet containing 12 such boxes is:  
(a)  $160 \text{ cm}^3$    (b)  $180 \text{ cm}^3$    (c)  $160 \text{ cm}^2$       (d)  $180 \text{ cm}^2$
- A cuboidal water tank is 6 m long, 5 m wide and 4.5 m deep. How many litre of water can it hold?  
(a) 1350 liters   (b) 13500 liters      (c) 135000 liters      (d) 135 liters
- A cuboidal vessel is 10 m long and 8 m wide. How high must it be made to hold 380 cubic metres of a liquid?  
(a) 4.75 m      (b) 7.85 m      (c) 4.75 cm      (d) none of these
- The capacity of a cuboidal tank is 50000 litres. The length and depth are respectively 2.5 m and 10 m. Its breadth is  
(a) 4 m      (b) 3 m      (c) 2 m      (d) 5 m
- A godown measures  $40 \text{ m} \times 25 \text{ m} \times 10 \text{ m}$ . Find the maximum number of wooden crates each measuring  $1.5 \text{ m} \times 1.25 \text{ m} \times 0.5 \text{ m}$  that can be stored in the godown.  
(a) 18000      (b) 16000      (c) 15000      (d) 14000
- A paper is in the form of a rectangle ABCD in which  $AB = 18\text{cm}$  and  $BC = 14\text{cm}$ . A semicircular portion with BC as diameter is cut off. Find the area of the remaining paper (see in below figure).  
(a)  $175 \text{ cm}^2$    (b)  $165 \text{ cm}^2$    (c)  $145 \text{ cm}^2$       (d) none of these

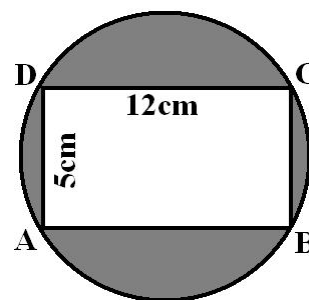
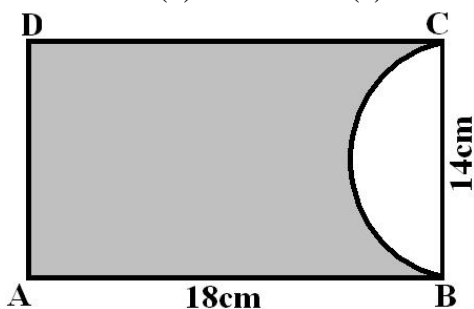

11. Find the area of the shaded region in the above sided figure. Take  $\pi = 3.14$

- (a)  $75 \text{ cm}^2$     (b)  $72 \text{ cm}^2$     (c)  $70 \text{ cm}^2$     (d) none of these

12. The perimeter of parallelogram PQRS is:

- (a) 12 cm    (b) 7 cm    (c) 38 cm    (d) 19 cm

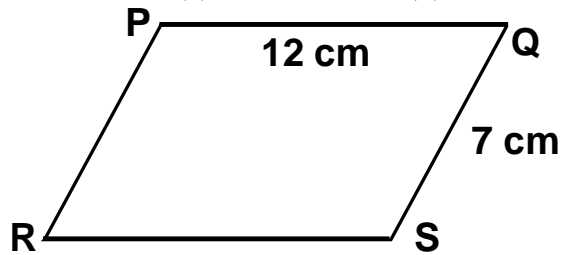

13. The area of the given below left figure is

- (a)  $45 \text{ cm}^2$     (b)  $11 \text{ cm}^2$     (c)  $49 \text{ cm}^2$     (d) none of these

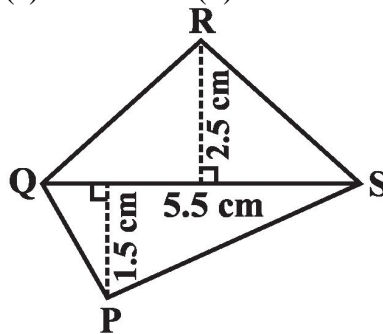
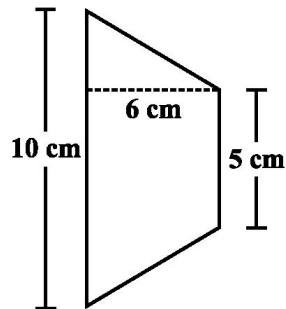

14. The area of the above sided right figure is

- (a)  $45 \text{ cm}^2$     (b)  $11 \text{ cm}^2$     (c)  $49 \text{ cm}^2$     (d) none of these

**PRACTICE QUESTIONS**  
**CLASS VIII: CHAPTER - 11**  
**MENSURATION**

1. Find the area of trapezium whose parallel sides are 24 cm and 20 cm and the distance between them is 15 cm.
2. The area of trapezium is  $1080 \text{ cm}^2$ . If the lengths of its parallel sides are 55.6 cm and 34.4 cm, find the distance between them.
3. The area of trapezium is  $352 \text{ cm}^2$  and the distance between its parallel sides is 16 cm. If one of the parallel sides is of length 25 cm, find the length of the other side.
4. Find the lateral surface area of the cuboids whose dimensions are:
  - (i). Length = 22cm, breadth = 12 cm and height = 7.5 cm
  - (ii). Length = 15cm, breadth = 6 cm and height = 9 cm
  - (iii). Length = 24 m, breadth = 25 cm and height = 6 m
5. The circumference of the base of a cylinder is 176 cm and its height is 65 m. Find its curved surface area and total surface area of the cylinder.
6. Find the curved surface area and total surface area of the cylinders whose dimensions are:
  - (i). radius = 7 cm and height = 35 cm.
  - (ii). radius = 14 cm and height = 10 cm.
  - (iii). radius = 10 cm and height = 25 cm.
7. Find the area of a rhombus whose diagonals are of lengths 15 cm and 25 cm.
8. The area of a rhombus is  $360 \text{ cm}^2$  and one of the diagonals is 18 cm. Find the other diagonal.
9. The diagonal of a quadrilateral shaped field is 25 m and the perpendiculars dropped on it from the remaining opposite vertices are 18 m and 12 m. Find the area of the field.
10. An aquarium is in the form of a cuboid whose external measures are  $40 \text{ cm} \times 15 \text{ cm} \times 20 \text{ cm}$ . The base, side faces and back face are to be covered with a coloured paper. Find the area of the paper needed?
11. Find the area of the following trapeziums

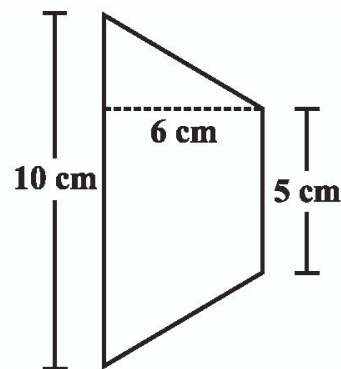
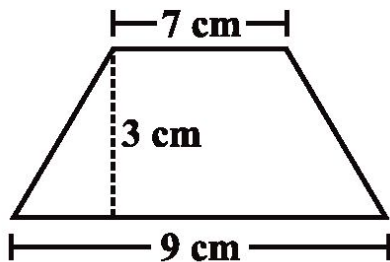

12. Find the area of the quadrilateral PQRS in the adjoining figure:

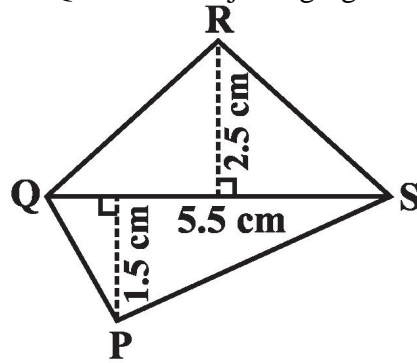

13. Find the area of a rhombus whose diagonals are of lengths 10 cm and 8.2 cm.

14. Find the area of the quadrilaterals in the adjoining figures:

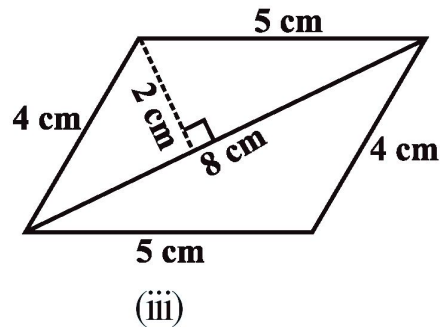
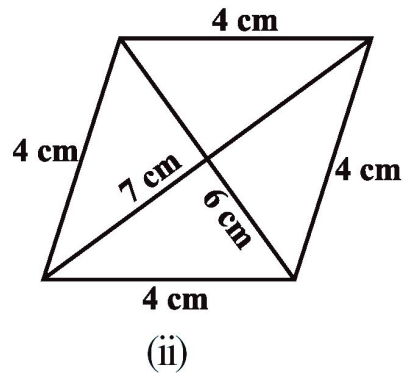
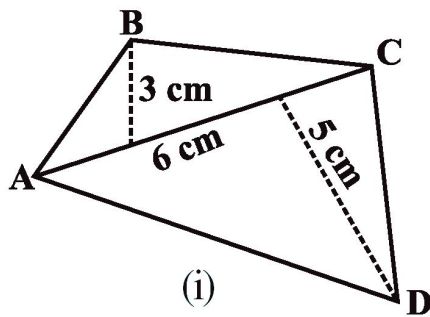

15. The length, breadth and height of a room are 5 m, 4 m and 3 m respectively. Find the cost of white washing the walls of the room and the ceiling at the rate of Rs 7.50 per  $m^2$ .

16. The floor of a rectangular hall has a perimeter 250 m. If the cost of painting the four walls at the rate of Rs 10 per  $m^2$  is Rs 15000, find the height of the hall.

17. A cubical box has each edge 10 cm and another cuboidal box is 12.5 cm long, 10 cm wide and 8 cm high.

- (i) Which box has the greater lateral surface area and by how much?
- (ii) Which box has the smaller total surface area and by how much?

18. The curved surface area of a right circular cylinder of height 14 cm is  $88\text{ cm}^2$ . Find the diameter of the base of the cylinder.

19. It is required to make a closed cylindrical tank of height 1 m and base diameter 140 cm from a metal sheet. How many square metres of the sheet are required for the same?

20. The diameter of a roller is 84 cm and its length is 120 cm. It takes 500 complete revolutions to move once over to level a playground. Find the area of the playground in  $\text{m}^2$ .
21. Curved surface area of a right circular cylinder is  $4.4 \text{ m}^2$ . If the radius of the base of the cylinder is 0.7 m, find its height.
22. Find the lateral or curved surface area of a closed cylindrical petrol storage tank that is 4.2 m in diameter and 4.5 m high.
23. A matchbox measures  $4 \text{ cm} \times 2.5 \text{ cm} \times 1.5 \text{ cm}$ . What will be the volume of a packet containing 12 such boxes?
24. A cuboidal water tank is 6 m long, 5 m wide and 4.5 m deep. How many litres of water can it hold?
25. A cuboidal vessel is 10 m long and 8 m wide. How high must it be made to hold 380 cubic metres of a liquid?
26. The capacity of a cuboidal tank is 50000 litres of water. Find the breadth of the tank, if its length and depth are respectively 2.5 m and 10 m.
27. The circumference of the base of a cylindrical vessel is 132 cm and its height is 25 cm. How many litres of water can it hold?
28. If the lateral surface of a cylinder is  $94.2 \text{ cm}^2$  and its height is 5 cm, then find (i) radius of its base (ii) its volume. (Use  $\pi = 3.14$ )

**HOT'S QUESTIONS**  
**CLASS VIII: CHAPTER - 11**  
**MENSURATION**

1. Mary wants to decorate her Christmas tree. She wants to place the tree on a wooden box covered with coloured paper with picture of Santa Claus on it. She must know the exact quantity of paper to buy for this purpose. If the box has length, breadth and height as 80 cm, 40 cm and 20 cm respectively how many square sheets of paper of side 40 cm would she require?
2. A wall of length 10 m was to be built across an open ground. The height of the wall is 4 m and thickness of the wall is 24 cm. If this wall is to be built up with bricks whose dimensions are 24 cm  $\times$  12 cm  $\times$  8 cm, how many bricks would be required?
3. A matchbox measures 4 cm  $\times$  2.5 cm  $\times$  1.5 cm. What will be the volume of a packet containing 12 such boxes?
4. A cuboidal water tank is 6 m long, 5 m wide and 4.5 m deep. How many litres of water can it hold? ( $1 \text{ m}^3 = 1000 \text{ l}$ )
5. A cuboidal vessel is 10 m long and 8 m wide. How high must it be made to hold 380 cubic metres of a liquid?
6. Find the cost of digging a cuboidal pit 8 m long, 6 m broad and 3 m deep at the rate of Rs 30 per  $\text{m}^3$ .
7. The capacity of a cuboidal tank is 50000 litres of water. Find the breadth of the tank, if its length and depth are respectively 2.5 m and 10 m.
8. Hameed has built a cubical water tank with lid for his house, with each outer edge 1.5 m long. He gets the outer surface of the tank excluding the base, covered with square tiles of side 25 cm. Find how much he would spend for the tiles, if the cost of the tiles is Rs 360 per dozen.
9. The length, breadth and height of a room are 5 m, 4 m and 3 m respectively. Find the cost of white washing the walls of the room and the ceiling at the rate of Rs 7.50 per  $\text{m}^2$ .
10. The floor of a rectangular hall has a perimeter 250 m. If the cost of painting the four walls at the rate of Rs 10 per  $\text{m}^2$  is Rs 15000, find the height of the hall.
11. The paint in a certain container is sufficient to paint an area equal to 9.375  $\text{m}^2$ . How many bricks of dimensions 22.5 cm  $\times$  10 cm  $\times$  7.5 cm can be painted out of this container?
12. A small indoor greenhouse (herbarium) is made entirely of glass panes (including base) held together with tape. It is 30 cm long, 25 cm wide and 25 cm high. (i) What is the area of the glass? (ii) How much of tape is needed for all the 12 edges?
13. Shanti Sweets Stall was placing an order for making cardboard boxes for packing their sweets. Two sizes of boxes were required. The bigger of dimensions 25 cm  $\times$  20 cm  $\times$  5 cm and the smaller of dimensions 15 cm  $\times$  12 cm  $\times$  5 cm. For all the overlaps, 5% of the total surface area is required extra. If the cost of the cardboard is Rs 4 for 1000  $\text{cm}^2$ , find the cost of cardboard required for supplying 250 boxes of each kind.

14. Parveen wanted to make a temporary shelter for her car, by making a box-like structure with tarpaulin that covers all the four sides and the top of the car (with the front face as a flap which can be rolled up). Assuming that the stitching margins are very small, and therefore negligible, how much tarpaulin would be required to make the shelter of height 2.5 m, with base dimensions  $4\text{ m} \times 3\text{ m}$ ?
15. A plastic box 1.5 m long, 1.25 m wide and 65 cm deep is to be made. It is to be open at the top. Ignoring the thickness of the plastic sheet, determine: (i) The area of the sheet required for making the box. (ii) The cost of sheet for it, if a sheet measuring  $1\text{ m}^2$  costs Rs 20.
16. A village, having a population of 4000, requires 150 litres of water per head per day. It has a tank measuring  $20\text{ m} \times 15\text{ m} \times 6\text{ m}$ . For how many days will the water of this tank last?
17. A godown measures  $40\text{ m} \times 25\text{ m} \times 10\text{ m}$ . Find the maximum number of wooden crates each measuring  $1.5\text{ m} \times 1.25\text{ m} \times 0.5\text{ m}$  that can be stored in the godown.
18. A solid cube of side 12 cm is cut into eight cubes of equal volume. What will be the side of the new cube? Also, find the ratio between their surface areas.
19. A river 3 m deep and 40 m wide is flowing at the rate of 2 km per hour. How much water will fall into the sea in a minute?
20. Savitri had to make a model of a cylindrical kaleidoscope for her science project. She wanted to use chart paper to make the curved surface of the kaleidoscope. What would be the area of chart paper required by her, if she wanted to make a kaleidoscope of length 25 cm with a 3.5 cm radius? (Take  $\pi = \frac{22}{7}$ )
21. The curved surface area of a right circular cylinder of height 14 cm is  $88\text{ cm}^2$ . Find the diameter of the base of the cylinder.
22. It is required to make a closed cylindrical tank of height 1 m and base diameter 140 cm from a metal sheet. How many square metres of the sheet are required for the same?
23. The diameter of a roller is 84 cm and its length is 120 cm. It takes 500 complete revolutions to move once over to level a playground. Find the area of the playground in  $\text{m}^2$ .
24. A cylindrical pillar is 50 cm in diameter and 3.5 m in height. Find the cost of painting the curved surface of the pillar at the rate of Rs 12.50 per  $\text{m}^2$ .
25. Curved surface area of a right circular cylinder is  $4.4\text{ m}^2$ . If the radius of the base of the cylinder is 0.7 m, find its height.
26. The inner diameter of a circular well is 3.5 m. It is 10 m deep. Find (i) its inner curved surface area, (ii) the cost of plastering this curved surface at the rate of Rs 40 per  $\text{m}^2$ .
27. In a hot water heating system, there is a cylindrical pipe of length 28 m and diameter 5 cm. Find the total radiating surface in the system.
28. The students of a Vidyalaya were asked to participate in a competition for making and decorating penholders in the shape of a cylinder with a base, using cardboard. Each penholder was to be of radius 3 cm and height 10.5 cm. The Vidyalaya was to supply the competitors with cardboard. If there were 35 competitors, how much cardboard was required to be bought for the competition?

29. The pillars of a temple are cylindrically shaped. If each pillar has a circular base of radius 20 cm and height 10 m, how much concrete mixture would be required to build 14 such pillars?
30. It costs Rs 2200 to paint the inner curved surface of a cylindrical vessel 10 m deep. If the cost of painting is at the rate of Rs 20 per  $\text{m}^2$ , find (i) inner curved surface area of the vessel, (ii) radius of the base, (iii) capacity of the vessel.
31. The capacity of a closed cylindrical vessel of height 1 m is 15.4 litres. How many square metres of metal sheet would be needed to make it?
32. A lead pencil consists of a cylinder of wood with a solid cylinder of graphite filled in the interior. The diameter of the pencil is 7 mm and the diameter of the graphite is 1 mm. If the length of the pencil is 14 cm, find the volume of the wood and that of the graphite.
33. A patient in a hospital is given soup daily in a cylindrical bowl of diameter 7 cm. If the bowl is filled with soup to a height of 4 cm, how much soup the hospital has to prepare daily to serve 250 patients?
34. The circumference of the base of a cylindrical vessel is 132 cm and its height is 25 cm. How many litres of water can it hold? ( $1000 \text{ cm}^3 = 1 \text{ l}$ )
35. The inner diameter of a cylindrical wooden pipe is 24 cm and its outer diameter is 28 cm. The length of the pipe is 35 cm. Find the mass of the pipe, if  $1 \text{ cm}^3$  of wood has a mass of 0.6 g.
36. A soft drink is available in two packs – (i) a tin can with a rectangular base of length 5 cm and width 4 cm, having a height of 15 cm and (ii) a plastic cylinder with circular base of diameter 7 cm and height 10 cm. Which container has greater capacity and by how much?
37. If the lateral surface of a cylinder is  $94.2 \text{ cm}^2$  and its height is 5 cm, then find (i) radius of its base (ii) its volume. (Use  $\pi = 3.14$ ).
38. At a Ramzan Mela, a stall keeper in one of the food stalls has a large cylindrical vessel of base radius 15 cm filled up to a height of 32 cm with orange juice. The juice is filled in small cylindrical glasses of radius 3 cm up to a height of 8 cm, and sold for Rs 3 each. How much money does the stall keeper receive by selling the juice completely?
39. A child playing with building blocks, which are of the shape of cubes, has built a structure as shown in below Fig. If the edge of each cube is 3 cm, find the volume of the structure built by the child.

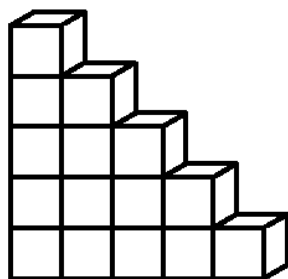

40. A metal pipe is 77 cm long. The inner diameter of a cross section is 4 cm, the outer diameter being 4.4 cm (see the above sided right Fig.). Find its (i) inner curved surface area, (ii) outer curved surface area, (iii) total surface area.



**MCQ WORKSHEET-I**  
**CLASS VIII: CHAPTER - 12**  
**EXPONENTS AND POWERS**

1. Express 256 as a power 4.  
(a)  $4^8$                       (b)  $2^8$                       (c)  $4^4$                       (d) none of these
2. Express 729 as a power of 3  
(a)  $3^8$                       (b)  $3^6$                       (c)  $9^3$                       (d) none of these
3. Express 2048 as a power 2.  
(a)  $2^{16}$                       (b)  $2^8$                       (c)  $4^8$                       (d) none of these
4. Which one is greater?  
(a)  $2^3$                       (b)  $3^2$                       (c)  $1^8$                       (d)  $4^2$
5. Express 432 as a product of powers of prime factors.  
(a)  $2^3 \times 3^3$                       (b)  $2^4 \times 3^3$                       (c)  $16 \times 27$                       (d) none of these
6. The value of  $(-1)^{55}$  is  
(a) -1                      (b) 1                      (c) 0                      (d) none of these
7. The value of  $(-1)^{500}$  is  
(a) -1                      (b) 1                      (c) 0                      (d) none of these
8. The value of  $2^8$  is  
(a) 128                      (b) 256                      (c) 512                      (d) none of these
9. Simplify and write in exponential form of  $2^2 \times 2^5$   
(a)  $2^3$                       (b)  $2^7$                       (c) 128                      (d) none of these
10. Simplify and write in exponential form of  $(-4)^{100} \times (-4)^{20}$   
(a)  $(-4)^{120}$                       (b)  $(-4)^{80}$                       (c)  $(-4)^{2000}$                       (d) none of these
11. Simplify and write in exponential form of  $5^2 \times 5^7 \times 5^{12}$   
(a)  $5^3$                       (b)  $5^7$                       (c)  $5^{21}$                       (d) none of these
12. The value of  $2^2$   
(a) 3                      (b) 10                      (c) 4                      (d) 7
13. The exponent in the expression  $3^7$  is \_\_\_\_\_ .  
(a) 1                      (b) 7                      (c) 0                      (d) 3
14. The value of  $3^0$  is \_\_\_\_\_ .  
(a) 0                      (b) 3                      (c) 1                      (d) None of these
15. Multiplicative inverse of  $\frac{1}{7}$  is \_\_\_\_\_ .  
(a) 49                      (b) 5                      (c) 7                      (d) -14

**MCQ WORKSHEET-II**  
**CLASS VIII: CHAPTER - 12**  
**EXPONENTS AND POWERS**

1. Fill in the Blank  $a^m \div a^n = a^{\dots\dots\dots}$  Where m and n are natural numbers:-  
(a) mn                      (b) m + n                      (c) m - n                      (d) m  $\div$  n
  2. Express  $(2a)^4$  in exponential form.  
(a)  $4a^3$                       (b)  $16a^4$                       (c)  $2a^4$                       (d)  $8a^4$
  3. The value of  $\frac{1}{3^2}$  is equal to \_\_\_\_\_ .  
(a)  $\frac{1}{9}$                       (b) 1                      (c) -6                      (d)  $\frac{1}{3}$
  4. Find the value of  $11^2$   
(a) 22                      (b) 9                      (c) 121                      (d) 13
  5. In simplified form  $(3^0 + 4^0 + 5^0)^0$  is equals to  
(a) 12                      (b) 3                      (c) 12                      (d) 1
  6. Find the value of  $\left(\frac{2}{3}\right)^2$   
(a)  $\frac{4}{9}$                       (b)  $\frac{9}{4}$                       (c)  $\frac{-2}{9}$                       (d) 0
  7. In standard form 52,00,00,000 is equal to \_\_\_\_\_ .  
(a)  $5.2 \times 10^7$                       (b)  $5.2 \times 10^8$                       (c)  $52 \times 10^8$                       (d)  $52 \times 100,00,000$
  8. Usual form of the expression  $10^4$  is given by \_\_\_\_\_ .  
(a) 100,00                      (b) 1,0000                      (c)  $10 \times 10^4$                       (d) 10,000
  9. 1 micron is equals to \_\_\_\_\_ .  
(a)  $\frac{1}{1000000}$  m                      (b)  $10^6$  m                      (c)  $10^5$  m                      (d)  $10^7$  m
  10. The approximate distance of moon from the earth is 384,467,000 m and in exponential form this distance can be written as \_\_\_\_\_ .  
(a)  $3.84,467 \times 10^8$  m                      (b)  $384,467 \times 10^{-8}$  m                      (c)  $384,467 \times 10^{-9}$  m                      (d)  $3.844,67 \times 10^{-13}$  m
  11.  $7 \times 10^{-5}$  m is the standard form of which of the following \_\_\_\_\_ .  
(a) 0.0007 m                      (b) 0.000007 m                      (c) 0.0000007 m                      (d) 0.00007 m
  12. The standard form of 4050000 is given by \_\_\_\_\_ .  
(a)  $4.05 \times 10^6$                       (b)  $40.5 \times 10^9$                       (c)  $405 \times 10^6$                       (d)  $4.05 \times 10^{-6}$
- .....

**MCQ WORKSHEET-III**  
**CLASS VIII: CHAPTER - 12**  
**EXPONENTS AND POWERS**

1. Which one of the following is the value of  $1^{15}$   
(a) 0                      (b) 15                      (c) 1                      (d) None of these
2. Fill in the blank :  $(-1)^{\text{even number}} = \underline{\hspace{2cm}}$ .  
(a)  $2 \times (-1)$               (b) 1                      (c) 0                      (d)  $-1^3$
3. Fill in the blank :  $(-1)^{\text{odd number}} = \underline{\hspace{2cm}}$ .  
(a) 1                      (b) -1                      (c) 2                      (d) 0
4. Value of  $(3^0 + 2^0) \times 5^0$  is  
(a) 1                      (b) 25                      (c) 2                      (d) 0
5. The value of  $7^2$  is  $\underline{\hspace{2cm}}$ .  
(a) 7                      (b) 49                      (c) 2                      (d) 14
6. The Base in the expression  $8^{10}$  is  $\underline{\hspace{2cm}}$ .  
(a) 10                      (b) 2                      (c) 8                      (d) 800
7. The value of  $100^0$  is  $\underline{\hspace{2cm}}$ .  
(a) 0                      (b) 100                      (c) 1                      (d) None of these
8. Find the number from the following expanded form :  $9 \times 10^5 + 2 \times 10^2 + 3 \times 10^1$   
(a) 900203              (b) 912351              (c) 905302              (d) 900230
9. Value of  $(2^3)^2$  is given by  $\underline{\hspace{2cm}}$ .  
(a) 64                      (b) 32                      (c) 12                      (d) None of these
10. The value of  $7^2 \div 7^3$  is given by  $\underline{\hspace{2cm}}$ .  
(a)  $\frac{1}{7}$                       (b) 7                      (c)  $\frac{1}{14}$                       (d) -7
11. The value of  $\frac{1}{5^2}$  is equal to -----.  
(a) -5                      (b) 25                      (c) -15                      (d)  $\frac{1}{25}$
12. In exponential form 140,000,000,000 Kg is given by  $\underline{\hspace{2cm}}$ .  
(a)  $1.4 \times 10^{10}$  Kg              (b)  $1.4 \times 10^9$  Kg              (c)  $14 \times 10^8$  Kg              (d)  $1.4 \times 10^{11}$  Kg
13. The expression ,  $(5^2 + 7^2 + 3^2)^0$  is equals to  
(a)  $15^6$                       (b) - 6                      (c) 1                      (d) 83
14. The value of  $\left(\frac{1}{6}\right)^2$  is  $\underline{\hspace{2cm}}$ .  
(a)  $\frac{1}{12}$                       (b)  $\frac{2}{3}$                       (c)  $\frac{1}{36}$                       (d) 2

**MCQ WORKSHEET-IV**  
**CLASS VIII: CHAPTER - 12**  
**EXPONENTS AND POWERS**

1. In standard form 56700000 is written as \_\_\_\_\_ .  
(a)  $5.67 \times 10^7$  (b)  $567 \times 10^7$  (c)  $5.67 \times 10^5$  (d)  $567 \times 100000$
2. Usual form of the expression  $9 \times 10^{-5}$  is given by \_\_\_\_\_ .  
(a) 0.00009 (b) 0.000009 (c)  $90 \times 10^{-4}$  (d)  $0.09 \times 10^{-3}$
3. The number 86,800,000,000,000,000,000,000 Kg is equal to \_\_\_\_\_ .  
(a)  $8.68 \times 10^{25}$  Kg (b)  $868 \times 10^{23}$  Kg (c)  $86.8 \times 10^{25}$  Kg (d)  $868 \times 10^{23}$  m
4. Charge of an electron is 0.000,000,000,000,000,000,16 coulomb and in exponential form it can be written as \_\_\_\_\_ .  
(a)  $16 \times 10^{-18}$  coulomb (b)  $1.6 \times 10^{-21}$  coulomb  
(c)  $1.6 \times 10^{-19}$  coulomb (d)  $16 \times 10^{-21}$  coulomb
5.  $13 \times 10^{-7}$  Km is the standard form of which of the following \_\_\_\_\_ .  
(a) 0.000000013 Km (b) 0.0000013 Km (c) 0.000000000013 Km (d) 0.00000000013 Km
6. The standard form of 9,030,000,000 is given by \_\_\_\_\_ .  
(a)  $9.03 \times 10^9$  (b)  $90.3 \times 10^7$  (c)  $903 \times 10^6$  (d)  $9.03 \times 10^{-9}$
7. Which one of the following is the value of  $3^5$   
(a) 3 (b) 15 (c) 2 (d) 243
8. Find the value of  $5^0 \times 7^0 \times 3^0$   
(a) 1 (b)  $\frac{1}{24}$  (c) 6 (d)  $\frac{1}{5} \times 7 \times 3$
9. 64 in exponential form is \_\_\_\_\_ .  
(a)  $2^6$  (b)  $16^2$  (c)  $\frac{1}{8^2}$  (d)  $2^4$
10. The value of  $2^0 \times 3^0 \times 4^0$  is  
(a) 1 (b) 0 (c) 24 (d) None of these
11. 1024 in exponential form is \_\_\_\_\_ .  
(a)  $2^6$  (b)  $16^2$  (c)  $\frac{1}{8^2}$  (d) none of these
12. The value of  $\frac{2^2}{3^2}$  in the exponential form is  
(a)  $\left(\frac{2}{3}\right)^4$  (b)  $\left(\frac{2}{3}\right)^2$  (c)  $\left(\frac{2}{3}\right)^0$  (d) none of these

**MCQ WORKSHEET-V**  
**CLASS VIII: CHAPTER - 12**  
**EXPONENTS AND POWERS**

1. The value of  $(6^{-1} - 8^{-1})^{-1}$  is  
(a)  $\frac{-1}{2}$                       (b)  $-2$                       (c)  $\frac{1}{24}$                       (d) 24
2. The value of  $(5^{-1} \times 3^{-1})^{-1}$  is  
(a)  $\frac{-1}{15}$                       (b)  $\frac{1}{15}$                       (c) 15                      (d)  $-15$
3. The value of  $(2^{-1} - 4^{-1})^2$  is  
(a)  $\frac{-1}{16}$                       (b)  $\frac{1}{16}$                       (c) 4                      (d)  $-4$
4. The value of  $\left(\frac{1}{2}\right)^{-2} + \left(\frac{1}{3}\right)^{-2} + \left(\frac{1}{4}\right)^{-2}$  is  
(a)  $\frac{61}{144}$                       (b)  $\frac{144}{61}$                       (c) 29                      (d) none of these
5. The value of  $\left\{6^{-1} + \left(\frac{3}{2}\right)^{-1}\right\}^{-1}$  is  
(a)  $\frac{2}{3}$                       (b)  $\frac{5}{6}$                       (c)  $\frac{6}{5}$                       (d) none of these
6. The value of  $\left(\frac{-1}{2}\right)^{-6}$  is  
(a)  $-64$                       (b)  $\frac{-1}{64}$                       (c)  $\frac{1}{64}$                       (d) 64
7. The value of  $\left\{\left(\frac{3}{4}\right)^{-1} - \left(\frac{1}{4}\right)^{-1}\right\}^{-1}$  is  
(a)  $\frac{3}{8}$                       (b)  $\frac{-3}{8}$                       (c)  $\frac{-8}{3}$                       (d)  $\frac{8}{3}$
8. The value of  $\left[\left\{\left(-\frac{1}{2}\right)^2\right\}^{-2}\right]^{-1}$  is  
(a)  $\frac{-1}{16}$                       (b)  $\frac{1}{16}$                       (c) 16                      (d)  $-16$

9. The value of  $\left(\frac{5}{6}\right)^0$  is  
(a) 0 (b)  $\frac{5}{6}$  (c)  $\frac{6}{5}$  (d) none of these

10. The value of  $\left(\frac{2}{3}\right)^{-5}$  is  
(a)  $\frac{32}{243}$  (b)  $\frac{-243}{32}$  (c)  $\frac{243}{32}$  (d)  $\frac{-32}{243}$

11. By what number should be multiplied to get ?  
(a)  $\frac{4}{5}$  (b)  $\frac{-4}{5}$  (c)  $\frac{5}{4}$  (d) none of these

12. If  $\left(\frac{5}{3}\right)^{-5} \times \left(\frac{5}{3}\right)^{11} = \left(\frac{5}{3}\right)^{8x}$ , then the value of x is  
(a) 2 (b)  $\frac{1}{2}$  (c)  $\frac{-1}{2}$  (d) -2

13. The value of  $\left(\frac{-1}{2}\right)^3$  is  
(a)  $\frac{-3}{2}$  (b)  $\frac{-1}{6}$  (c)  $\frac{-1}{8}$  (d) none of these

14. The value of  $\left(\frac{-2}{3}\right)^2$  is  
(a)  $\frac{4}{3}$  (b)  $\frac{-4}{9}$  (c)  $\frac{-2}{9}$  (d)  $\frac{4}{9}$

15. The value of  $\left\{\left(\frac{4}{-3}\right)^{-3}\right\}^2$  is  
(a)  $\frac{3}{4}$  (b)  $\frac{1024}{243}$  (c)  $\frac{729}{4096}$  (d)  $-\frac{3}{4}$



**MCQ WORKSHEET-VI**  
**CLASS VIII: CHAPTER - 12**  
**EXPONENTS AND POWERS**

1. The value of  $\left(\frac{-1}{5}\right)^3 \div \left(\frac{-1}{5}\right)^8$  is  
(a)  $\left(\frac{-1}{5}\right)^5$       (b)  $(-5)^5$       (c)  $\left(\frac{1}{5}\right)^5$       (d)  $\left(\frac{-1}{5}\right)^{11}$
2. The value of  $\left\{\left(\frac{1}{3}\right)^{-3} - \left(\frac{1}{2}\right)^{-3}\right\} \div \left(\frac{1}{4}\right)^{-3}$  is  
(a)  $\frac{19}{64}$       (b)  $\frac{27}{16}$       (c)  $\frac{64}{19}$       (d) none of these
3. The value of  $\left\{\left(\frac{1}{3}\right)^2\right\}^4$  is  
(a)  $\left(\frac{1}{3}\right)^6$       (b)  $\left(\frac{1}{3}\right)^{24}$       (c)  $\left(\frac{1}{3}\right)^{16}$       (d)  $\left(\frac{1}{3}\right)^8$
4. The value of  $\left(\frac{-3}{2}\right)^{-1}$  is  
(a)  $\frac{2}{3}$       (b)  $\frac{-2}{3}$       (c)  $\frac{3}{2}$       (d) none of these
5. The value of  $(3^2 - 2^2) \times \left(\frac{2}{3}\right)^{-3}$  is  
(a)  $\frac{45}{8}$       (b)  $\frac{135}{8}$       (c)  $\frac{8}{135}$       (d)  $\frac{8}{45}$
6. If  $\left(\frac{4}{9}\right)^4 \times \left(\frac{4}{9}\right)^{-7} = \left(\frac{4}{9}\right)^{2x-1}$ , then the value of  $x$  is  
(a)  $-1$       (b)  $\frac{1}{2}$       (c)  $\frac{-1}{2}$       (d) none of these
7. If  $5^{2x+1} \div 25 = 125$ , then the value of  $x$  is  
(a)  $2$       (b)  $\frac{1}{2}$       (c)  $\frac{-1}{2}$       (d)  $-2$
8. The value of  $(3^{-1} + 4^{-1})^{-1} \div 5^{-1}$  is  
(a)  $\frac{7}{10}$       (b)  $\frac{7}{15}$       (c)  $\frac{7}{5}$       (d)  $\frac{12}{35}$

9. If  $(2^{3x-1} + 10) \div 7 = 6$ , then the value of  $x$  is  
(a) 2 (b) 0 (c) 1 (d) -2

10. If  $\left(\frac{7}{12}\right)^{-4} \times \left(\frac{7}{12}\right)^{3x} = \left(\frac{7}{12}\right)^5$ , then the value of  $x$  is  
(a) -1 (b) 1 (c) 2 (d) 3

11. The value of  $\left(\frac{-2}{5}\right)^7 \div \left(\frac{-2}{5}\right)^5$  is  
(a)  $\left(\frac{-2}{5}\right)^{12}$  (b)  $\frac{25}{4}$  (c)  $\frac{-4}{25}$  (d)  $\frac{4}{25}$

12. The value of  $\left(\frac{1}{2}\right)^{-2} + \left(\frac{2}{3}\right)^{-2} + \left(\frac{3}{4}\right)^{-2}$  is  
(a)  $\frac{289}{36}$  (b)  $\frac{313}{72}$  (c)  $\frac{27}{4}$  (d)  $\frac{241}{36}$





**PRACTICE QUESTIONS**  
**CLASS VIII: CHAPTER - 12**  
**EXPONENTS AND POWERS**

1. Express:
  - (i) 729 as a power of 3
  - (ii) 128 as a power of 2
  - (iii) 343 as a power of 7
  - (iv) 256 as a power 2.
2. Which one is greater  $2^3$  or  $3^2$ ?
3. Which one is greater  $8^2$  or  $2^8$ ?
4. Express the following numbers as a product of powers of prime factors:
  - (i) 72 (ii) 432 (iii) 1000 (iv) 16000
5. Express each of the following numbers using exponential notation:
  - (i) 512 (ii) 343 (iii) 729 (iv) 3125
6. Simplify:
  - (i)  $(-4)^3$  (ii)  $(-3) \times (-2)^3$  (iii)  $(-3)^2 \times (-5)^2$  (iv)  $(-2)^3 \times (-10)^3$
7. Compare the following numbers:
  - (i)  $2.7 \times 10^{12}$  ;  $1.5 \times 10^8$  (ii)  $4 \times 10^{14}$  ;  $3 \times 10^{17}$
8. Simplify and write in exponential form:
  - (i)  $2^5 \times 2^3$
  - (ii)  $p^3 \times p^2$
  - (iii)  $4^3 \times 4^2$
  - (iv)  $a^3 \times a^2 \times a^7$
  - (v)  $5^3 \times 5^7 \times 5^{12}$
  - (vi)  $(-4)^{100} \times (-4)^{20}$
9. Simplify and write in exponential form:
  - (i)  $2^9 \div 2^3$
  - (ii)  $10^8 \div 10^4$
  - (iii)  $9^{11} \div 9^7$
  - (iv)  $20^{15} \div 20^{13}$
  - (v)  $7^{13} \div 7^{10}$
10. Express the following terms in the exponential form:
  - (i)  $(2 \times 3)^5$  (ii)  $(2a)^4$  (iii)  $(-4m)^3$

11. Simplify and write the answer in exponential form:

(i)  $6^{2^4}$

(ii)  $(2^2)^{100}$

(iii)  $(7^{50})^2$

(iv)  $(5^3)^7$

12. Expand: (i)  $\left(\frac{3}{5}\right)^4$  (ii)  $\left(\frac{4}{7}\right)^5$

13. Write exponential form for  $8 \times 8 \times 8 \times 8$  taking base as 2.

14. Simplify and write the answer in the exponential form.

(i)  $\left(\frac{3^7}{3^2}\right) \times 3^5$  (ii)  $2^3 \times 2^2 \times 2^5$  (iii)  $(6^2 \times 6^4) \div 6^3$

(iv)  $\left[(2^2)^3 \times 3^6\right] \times 5^6$  (v)  $8^2 \div 2^3$

15. Simplify:

(i)  $\frac{12^4 \times 9^3 \times 4}{6^3 \times 8^2 \times 27}$  (ii)  $2^3 \times a^3 \times 5a^4$  (iii)  $\frac{2 \times 3^4 \times 2^5}{9 \times 4^2}$

16. Express each of the following as a product of prime factors only in exponential form:

(i)  $108 \times 192$  (ii) 270 (iii)  $729 \times 64$  (iv) 768

17. Simplify:

(i)  $\frac{(2^5)^2 \times 7^3}{8^3 \times 7}$  (ii)  $\frac{25 \times 5^2 \times t^8}{10^3 \times t^4}$  (iii)  $\frac{3^5 \times 10^5 \times 25}{5^7 \times 6^5}$

18. Simplify and write the answer in the exponential form:

(i)  $(2^5 \div 2^8)^5 \times 2^{-5}$

(ii)  $(-4)^{-3} \times (5)^{-3} \times (-5)^{-3}$

(iii)  $\frac{1}{8} \times (3)^{-3}$

(iv)  $(-3)^4 \times \left(\frac{5}{3}\right)^4$

19. Simplify:

(i)  $\left\{\left(\frac{1}{3}\right)^{-2} - \left(\frac{1}{2}\right)^{-3}\right\} \div \left(\frac{1}{4}\right)^{-2}$

(ii)  $\left(\frac{5}{8}\right)^{-7} \times \left(\frac{8}{5}\right)^{-5}$

20. Simplify:

(i)  $\frac{25 \times t^{-4}}{5^{-3} \times 10 \times t^{-8}} (t \neq 0)$

(ii)  $\frac{3^{-5} \times 10^{-5} \times 125}{5^{-7} \times 6^{-5}}$

21. Find  $m$  so that  $(-3)^{m+1} \times (-3)^5 = (-3)^7$

22. Find the value of  $m$  for which  $5^m \div 5^{-3} = 5^5$ .

23. Write the following numbers in standard form.

- (i) 0.000000564      (ii) 0.0000021      (iii) 21600000  
(iv) 15240000      (v) 6020000000000000

24. Express the following numbers in standard form.

- (i) 0.0000000000000000000000035  
(ii) 4050000000000  
(iii) 51000000000000000000  
(iv) 0.0000000000000000000000000000625  
(v) 0.00000000000000000000001257

25. Express the following numbers in usual form.

- (i)  $3.52 \times 10^5$       (ii)  $7.54 \times 10^{-4}$       (iii)  $3 \times 10^{-5}$       (iv)  $5.25 \times 10^{-7}$       (v)  $8.525 \times 10^9$

26. Express the number appearing in the following statements in standard form.

- (i) 1 micron is equal to  $\frac{1}{1000000}$  m.  
(ii) Charge of an electron is 0.000,000,000,000,000,000,16 coulomb.  
(iii) Size of a bacteria is 0.0000005 m  
(iv) Size of a plant cell is 0.00001275 m  
(v) Thickness of a thick paper is 0.07 mm  
(vi) Mass of Uranus = 86,800,000,000,000,000,000,000 kg  
(vii) Mass of the Earth = 5,976,000,000,000,000,000,000,000 kg  
(viii) Distance of Sun from the centre of our Galaxy = 300,000,000,000,000,000,000 m  
(ix) Sun is located 300,000,000,000,000,000,000 m from the centre of our Milky Way Galaxy.  
(x) The distance between Sun and Saturn is 1,433,500,000,000 m

27. Express the following numbers in standard form.

- (i) 0.000035 (ii) 4050000

28. In a stack there are 5 books each of thickness 20mm and 5 paper sheets each of thickness 0.016 mm. What is the total thickness of the stack.



**MCQ WORKSHEET-I**  
**CLASS VIII: CHAPTER - 13**  
**DIRECT AND INVERSE PROPORTIONS**

1. If the cost of 1 kg of sugar is Rs 18, then what would be the cost of 3 kg sugar?  
(a) Rs. 54                      (b) Rs. 6                      (c) Rs. 18                      (d) none of these
2. If the cost of 9 toys is Rs. 333, find the cost of 16 such toys.  
(a) Rs. 594                      (b) Rs. 596                      (c) Rs. 592                      (d) none of these
3. If 25 metres of cloth costs of Rs. 1575, how many metres of it can be bought for Rs. 2016?  
(a) 30 m                      (b) 32 m                      (c) 36 m                      (d) none of these
4. A worker is paid Rs. 1110 for 6 days. If his total wages during a month are Rs. 4625, for how many days did he work?  
(a) 15 days                      (b) 25 days                      (c) 30 days                      (d) none of these
5. A car can cover a distance of 522 km on 36 litres of petrol. How far can it travel on 14 litres of petrol?  
(a) 230 km                      (b) 232 km                      (c) 203 km                      (d) none of these
6. If 13 metres of a uniform iron rod weighs 23.4 kg then what will be the weight of 6 metres of the same rod?  
(a) 10 kg                      (b) 20 kg                      (c) 10.8 kg                      (d) none of these
7. The length of the shadow of a 3m high pole at a certain time of the day is 3.6 m. What is the length of the height of another pole whose shadow at that time is 54 m long?  
(a) 30 m                      (b) 40 m                      (c) 45 m                      (d) none of these
8. Traveling 900 km by rail costs Rs. 280. What would be the fare for a journey of 360 km when a person travels by the same class?  
(a) Rs. 118                      (b) Rs. 112                      (c) Rs. 119                      (d) none of these
9. A train covers a distance of 51 km in 45 minutes. How long will it take to cover 221 km?  
(a) 3 hours                      (b)  $3\frac{1}{4}$  hrs                      (c)  $3\frac{1}{2}$  hrs                      (d) none of these
10. If 15 oranges cost Rs. 70, what do 39 oranges cost?  
(a) Rs. 180                      (b) Rs. 182                      (c) Rs. 190                      (d) none of these
11. If 8 kg sugar costs Rs. 148, how much sugar can be bought for Rs. 832.50?  
(a) 45 kg                      (b) 50 kg                      (c) 60 kg                      (d) none of these
12. The cost of 37m of silk is Rs. 3145. What length of this silk can be purchased for Rs. 1445?  
(a) 15 m                      (b) 16 m                      (c) 17 m                      (d) none of these
13. If 22.5 m of a uniform iron rod weighs 85.5 kg, what will be the length of 22.8 kg of the same rod?  
(a) 5 m                      (b) 6 m                      (c) 7 m                      (d) none of these

**HOT'S QUESTIONS**  
**CLASS VIII: CHAPTER - 12**  
**EXPONENTS AND POWERS**

1. Simplify:  $\frac{25 \times x^{-4}}{5^{-3} \times 10 \times x^{-8}}$

2. Simplify:  $\frac{3^{-5} \times 10^{-5} \times 125}{5^{-7} \times 6^{-5}}$

3. Simplify:  $\left[ \left\{ \left( \frac{-1}{4} \right)^2 \right\}^{-2} \right]^{-1}$

4. By what number should  $\left( \frac{5}{3} \right)^{-2}$  be multiplied so that the product may be  $\left( \frac{7}{3} \right)^{-1}$  ?

5. By what number should  $\left( \frac{1}{2} \right)^{-1}$  be multiplied so that the product may be  $\left( \frac{-4}{7} \right)^{-1}$  ?

6. By what number should  $\left( \frac{-3}{2} \right)^{-3}$  be divided so that the quotient may be  $\left( \frac{4}{27} \right)^{-2}$  ?

7. Find  $x$  so that  $\left( \frac{5}{3} \right)^{-5} \times \left( \frac{3}{5} \right)^{11} = \left( \frac{5}{3} \right)^{8x}$

8. Find  $x$  so that  $\left( \frac{2}{9} \right)^3 \times \left( \frac{2}{9} \right)^{-6} = \left( \frac{9}{2} \right)^{1-2x}$

9. By what number should  $(-12)^{-1}$  be divided so that the quotient may be  $\left( \frac{2}{3} \right)^{-1}$  ?

10. Find  $x$  so that  $\left( \frac{1}{4} \right)^{-3} \times (4)^8 = \left( \frac{1}{4} \right)^{-4x}$

11. Find  $x$  so that  $\left( \frac{-1}{2} \right)^{-19} \div \left( \frac{-1}{2} \right)^8 = \left( \frac{-1}{2} \right)^{1-2x}$

12. Find  $x$  so that  $\left( \frac{2}{3} \right)^3 \times \left( \frac{2}{3} \right)^5 = \left( \frac{3}{2} \right)^{-1-2x}$

13. Find  $x$  so that  $\left( \frac{2}{5} \right)^{-3} \times \left( \frac{5}{2} \right)^{-15} = \left( \frac{2}{5} \right)^{2+3x}$



**MCQ WORKSHEET-II**  
**CLASS VIII: CHAPTER - 13**  
**DIRECT AND INVERSE PROPORTIONS**

1. If the weight of 6 sheets of a paper is 162 grams, how many sheets of the same quality of paper would weigh 13.5 kg?  
(a) 300                      (b) 400                      (c) 500                      (d) none of these
2. 1152 bars of soap can be packed in 8 cartoons of the same size. How many such cartoons will be required to pack 3888 bars?  
(a) 27                      (b) 24                      (c) 25                      (d) none of these
3. If the thickness of a pile of 16 cardboards is 44mm, how many cardboards will be there in a pile which is 71.5 cm thick?  
(a) 270                      (b) 260                      (c) 250                      (d) none of these
4. At a particular time of a day, a 7m high flagstaff casts a shadow which is 8.2m long. What is the height of the building which casts a shadow 20.5 m in length at the same time?  
(a) 15.5 m                      (b) 16.5 m                      (c) 17.5 m                      (d) none of these
5. 15 men can build a 16.25m long wall up to a certain height in one day. How many men should be employed to build a wall of the same height but of length 26m in one day?  
(a) 27                      (b) 24                      (c) 25                      (d) none of these
6. In a hospital, the monthly consumption of milk of 60 patients is 1350 litres. How many patients can be accommodated in the hospital if the monthly ration of milk is raised 1710 litres, assuming that the quota per head remains the same?  
(a) 75                      (b) 76                      (c) 77                      (d) none of these
7. The extension in an elastic string varies directly as the weight hung on it. If a weight of 150 g produces an extension of 2.8 cm, what weight would produce an extension of 19.6 cm?  
(a) 1.5 kg                      (b) 1.05 kg                      (c) 15 kg                      (d) none of these
8. A car travels 432 km on 48 litres. How far would it travel on 20 litres of petrol?  
(a) 160 km                      (b) 180 km                      (c) 200 km                      (d) none of these
9. If 40m of a cloth costs Rs. 1940, how many metres can be bought for Rs. 727.50?  
(a) 15 m                      (b) 16 m                      (c) 17 m                      (d) none of these
10. A private taxi charges a fare of Rs. 260 for a journey of 200 km, how much would it travel for Rs. 279.50?  
(a) 200 km                      (b) 215 km                      (c) 200 km                      (d) none of these
11. Manoj types 540 words during half an hour, how many words would he type in 6 minutes?  
(a) 105                      (b) 106                      (c) 108                      (d) none of these
12. Rohit bought 12 registers for Rs. 156, find the cost of 7 such register.  
(a) Rs. 90                      (b) Rs. 91                      (c) Rs. 92                      (d) none of these

**MCQ WORKSHEET-III**  
**CLASS VIII: CHAPTER - 13**  
**DIRECT AND INVERSE PROPORTIONS**

1. Pranshu takes 125 minutes in walking a distance of 100m. What distance would he cover in 315 minutes?  
(a) 250 m                      (b) 252 m                      (c) 254 m                      (d) none of these
2. If the cost of 93m of a certain kind of plastic sheet is Rs. 1395, then what would it cost to buy 105m of such plastic sheet?  
(a) Rs. 1500                      (b) Rs. 1550                      (c) Rs. 1575                      (d) none of these
3. Ranjita types 1080 words in one hour. What is her gross words a minute rate?  
(a) 15                              (b) 16                              (c) 18                              (d) none of these
4. 68 boxes of a certain commodity require a shelf-length of 13.6 m. How many boxes of the same commodity would occupy a shelf-length of 20.4m?  
(a) 104                              (b) 106                              (c) 102                              (d) none of these
5. A worker is paid Rs. 200 for 8 days work. If he works for 20 days, how much will he get?  
(a) Rs. 500                      (b) Rs. 550                      (c) Rs. 575                      (d) none of these
6. If 52 men can do a piece of work in 35 days, in how many days 28 men will do it?  
(a) 65 days                      (b) 75 days                      (c) 80 days                      (d) none of these
7. If 56 men can do a piece of work in 42 days, how many men will do it in 14 days?  
(a) 165                              (b) 166                              (c) 168                              (d) none of these
8. 120 men have food provision for 200 days. After 5 days, 30 men died due to an cancer. How long will the remaining food last?  
(a) 260 days                      (b) 275 days                      (c) 250 days                      (d) none of these
9. If  $x$  and  $y$  varies inversely as each other and  $x = 10$  when  $y = 6$ . Find  $y$  when  $x = 15$ .  
(a) 5                                  (b) 6                                  (c) 4                                  (d) none of these
10. Shreya cycles to her school at an average speed of 12km/hr. It takes her 20 minutes to reach the school. If she wants to reach her school in 15 minutes, what should be her average speed?  
(a) 15 km/hr                      (b) 16 km/hr                      (c) 18 km/hr                      (d) none of these
11. 1000 soldiers in a fort has enough food for 20 days. But some soldiers were transferred to another fort and the food lasted for 25 days. How many soldiers were transferred?  
(a) 100                              (b) 200                              (c) 800                              (d) none of these
12. If  $x$  and  $y$  varies inversely as each other and  $x = 8$  when  $y = 32$ . Find  $y$  when  $x = 16$ .  
(a) 64                                  (b) 16                                  (c) 4                                  (d) none of these
13. If  $x$  and  $y$  varies inversely as each other and  $x = 8$  when  $y = 10$ . Find  $y$  when  $x = 2$ .  
(a) 40                                  (b) 16                                  (c) 4                                  (d) none of these



**MCQ WORKSHEET-IV**  
**CLASS VIII: CHAPTER - 13**  
**DIRECT AND INVERSE PROPORTIONS**

1. If  $x$  and  $y$  varies inversely as each other and  $x = 2$  when  $y = 40$ . Find  $x$  when  $x = 20$ .  
(a) 40                      (b) 16                      (c) 4                      (d) none of these
2. If  $x$  and  $y$  varies inversely as each other and  $x = 8$  when  $y = 10$ . Find  $y$  when  $x = 5$ .  
(a) 40                      (b) 16                      (c) 4                      (d) none of these
3. If  $a$  and  $b$  varies inversely as each other and  $a = 16$  when  $b = 4$ . Find  $b$  when  $a = 32$ .  
(a) 2                      (b) 8                      (c) 4                      (d) none of these
4. If  $a$  and  $b$  varies inversely as each other and  $a = 16$  when  $b = 4$ . Find  $b$  when  $a = 8$ .  
(a) 2                      (b) 8                      (c) 4                      (d) none of these
5. If  $x$  and  $y$  varies directly as each other and  $x = 4$  when  $y = 16$ . Find  $y$  when  $x = 9$ .  
(a) 48                      (b) 36                      (c) 4                      (d) none of these
6. If  $x$  and  $y$  varies directly as each other and  $x = 4$  when  $y = 16$ . Find  $y$  when  $x = 12$ .  
(a) 48                      (b) 36                      (c) 4                      (d) none of these
7. If  $x$  and  $y$  varies directly as each other and  $x = 4$  when  $y = 16$ . Find  $y$  when  $x = 1$ .  
(a) 48                      (b) 36                      (c) 4                      (d) none of these
8. If  $x$  and  $y$  varies directly as each other and  $x = 4$  when  $y = 16$ . Find  $y$  when  $x = 3$ .  
(a) 48                      (b) 36                      (c) 4                      (d) none of these
9. If 36 men can do a piece of work in 25 days, in how many days will 15 men do it?  
(a) 60 days                      (b) 75 days                      (c) 50 days                      (d) none of these
10. A work force of 50 men with a contractor an finish a piece of work in 5 months. In how many months the same work can be completed by 125 men?  
(a) 2                      (b) 8                      (c) 4                      (d) none of these
11. 1200 men can finish a stock of food in 35 days. How many more men should join the hostel so that the same stock may lst for 25 days?  
(a) 480                      (b) 360                      (c) 400                      (d) none of these
12. In a hostel of 50 girls, there are food provisions for 40 days. If 30 more girls join the hostel, how long will these provisions last?  
(a) 26 days                      (b) 20 days                      (c) 25 days                      (d) none of these
13. 18 men can reap a field in 35 days. For reaping the same field in 15 days, how many men are required?  
(a) 48                      (b) 36                      (c) 42                      (d) none of these
14. 55 cows can graze a field in 16 days. How many cows will graze the same field in 10 days?  
(a) 88                      (b) 66                      (c) 44                      (d) none of these

**PRACTICE QUESTIONS**  
**CLASS VIII: CHAPTER - 13**  
**DIRECT AND INVERSE PROPORTIONS**

1. The cost of 5 metres of a particular quality of cloth is Rs 210. Tabulate the cost of 2, 4, 10 and 13 metres of cloth of the same type.
2. An electric pole, 14 metres high, casts a shadow of 10 metres. Find the height of a tree that casts a shadow of 15 metres under similar conditions.
3. If the weight of 12 sheets of thick paper is 40 grams, how many sheets of the same paper would weigh  $2\frac{1}{2}$  kilograms?
4. A train is moving at a uniform speed of 75 km/hour.
  - (i) How far will it travel in 20 minutes?
  - (ii) Find the time required to cover a distance of 250 km.
5. The scale of a map is given as 1:30000000. Two cities are 4 cm apart on the map. Find the actual distance between them.
6. A machine in a soft drink factory fills 960 bottles in six hours. How many bottles will it fill in ten hours?
7. A photograph of a bacteria enlarged 50,000 times attains a length of 5 cm. What is the *actual* length of the bacteria? If the photograph is enlarged 20,000 times only, what would be its enlarged length?
8. In a model of a ship, the mast is 9 cm high, while the mast of the actual ship is 12 m high. If the length of the ship is 28 m, how long is the model ship?
9. A loaded truck travels 14 km in 25 minutes. If the speed remains the same, how far can it travel in 5 hours?
10. 6 pipes are required to fill a tank in 1 hour 20 minutes. How long will it take if only 5 pipes of the same type are used?
11. There are 100 students in a hostel. Food provision for them is for 20 days. How long will these provisions last, if 25 more students join the group?
12. If 15 workers can build a wall in 48 hours, how many workers will be required to do the same work in 30 hours?
13. A factory requires 42 machines to produce a given number of articles in 63 days. How many machines would be required to produce the same number of articles in 54 days?
14. A car takes 2 hours to reach a destination by travelling at the speed of 60 km/h. How long will it take when the car travels at the speed of 80 km/h?
15. A school has 8 periods a day each of 45 minutes duration. How long would each period be, if the school has 9 periods a day, assuming the number of school hours to be the same?

16. If a box of sweets is divided among 24 children, they will get 5 sweets each. How many would each get, if the number of the children is reduced by 4?
17. A farmer has enough food to feed 20 animals in his cattle for 6 days. How long would the food last if there were 10 more animals in his cattle?
18. A contractor estimates that 3 persons could rewire Jasminder's house in 4 days. If, he uses 4 persons instead of three, how long should they take to complete the job?
19. Observe the following tables and find which pair of variables (here  $x$  and  $y$ ) are in inverse proportion.

(i) 

$x$	50	40	30	20
$y$	5	6	7	8

(ii) 

$x$	100	200	300	400
$y$	60	30	20	15

(iii) 

$x$	90	60	45	30	20	5
$y$	10	15	20	25	30	35

20. Observe the following tables and find if  $x$  and  $y$  are directly proportional.

(i) 

$x$	20	17	14	11	8	5	2
$y$	40	34	28	22	16	10	4

(ii) 

$x$	6	10	14	18	22	26	30
$y$	4	8	12	16	20	24	28

(iii) 

$x$	5	8	12	15	18	20
$y$	15	24	36	60	72	100

21. A car travels 432 km on 48 litres of petrol. How far would it travel on 20 litres of petrol?
22. A private taxi charges a fare of Rs. 260 for a journey of 200 km. How much would it travel for Rs. 279.50?
23. Reema types 540 words during half an hour. How many words would she type in 6 minutes?
24. If 40 metres of a cloth costs Rs. 1940, how many metres can be bought for Rs. 727.50?

**Complete the following tables given that  $x$  varies directly as  $y$ .**

25.

$x$	2.5	.....	.....	15
$y$	5	8	12	.....

26.

$x$	5	.....	10	35	25	.....
$y$	8	12	.....	.....	.....	32

27.

x	6	8	10	.....	20
y	15	20	.....	40	.....

28.

x	4	9	.....	.....	3	.....
y	16	.....	48	36	.....	4

29.

x	3	5	7	9
y	.....	20	28	.....

30. If x and y vary inversely as each other and  $x = 10$  when  $y = 6$ . Find y when  $x = 15$ .

**Complete the following tables given that x varies inversely as y.**

31.

x	12	16	.....	8	.....
y	.....	6	4	.....	25

32.

x	16	32	8	128
y	4	.....	.....	0.25

33.

x	9	.....	81	243
y	27	9	.....	1



**HOT'S QUESTIONS**  
**CLASS VIII: CHAPTER - 13**  
**DIRECT AND INVERSE PROPORTIONS**

1. The amount of extension in an elastic spring varies directly as the weight hung on it. If a weight of 150 gm produces an extension of 2.9 cm, then what weight would produce an extension of 17.4 cm?
2. In a library 136 copies of a certain book require a shelf length of 3.4 m. How many copies of the same book would occupy a shelf length of 20.4m?
3. 11 men can dig  $6\frac{3}{4}$  m long trench in one day. How many men should be employed for digging 27 m long trench of the same type in one day?
4. The second-class railway fare for 240 km of journey is Rs. 15. What would be the fare for a journey of 139.2 km?
5. A worker is paid Rs. 200 for 8 days work. If his total income of the month is Rs. 875, for how many days did he work?
6. If 52 men can do piece of work in 35 days, in how many days 28 men will do it?
7. If 56 men can do a piece of work in 42 days. How many men will do it in 14 days?
8. 1200 men can finish a stock of food in 35 days. How many more men should join them so that the same stock may last for 25 days?
9. In a hostel of 50 girls there are food provisions for 40 days. If 30 more girls join the hostel, how long will these provisions last?
10. A group of 3 friends staying together consume 54kg of wheat every month. Some more friends join this group and they find that the same amount of wheat lasts for 18 days. How many new members are there in this group now?
11. 55 cows can graze a field in 16 days. How many cows will graze the same field in 10 days?
12. Seema weaves 25 baskets in 35 days. In how many days will she weave 110 baskets?
13. Three spraying machines working together can finish painting a house in 60 minutes. How long will it take for 5 machines of the same capacity to do the same job?
14. 5 men can complete a work in 8 days. How many days will it take if 12 men do the same work?
15. If 9 men can prepare 135 boxes in 3 hours, how many men are needed to prepare 270 boxes in 1 hour?

**MCQ WORKSHEET-I**  
**CLASS VIII: CHAPTER - 14**  
**FACTORISATION**

1. The factors of  $2x^2 - 7x + 3$  are:  
(a)  $(x - 3)(2x - 1)$                       (b)  $(x + 3)(2x + 1)$   
(c)  $(x - 3)(2x + 1)$                       (d)  $(x + 3)(2x - 1)$
  2. The factors of  $6x^2 + 5x - 6$  are:  
(a)  $(2x - 3)(3x - 2)$                       (b)  $(2x - 3)(3x + 2)$   
(c)  $(2x + 3)(3x - 2)$                       (d)  $(2x + 3)(3x + 2)$
  3. The factors of  $3x^2 - x - 4$  are:  
(a)  $(3x - 4)(x - 1)$                       (b)  $(3x - 4)(x + 1)$   
(c)  $(3x + 4)(x - 1)$                       (d)  $(3x + 4)(x + 1)$
  4. The factors of  $12x^2 - 7x + 1$  are:  
(a)  $(4x - 1)(3x - 1)$                       (b)  $(4x - 1)(3x + 1)$   
(c)  $(4x + 1)(3x - 1)$                       (d)  $(4x + 1)(3x + 1)$
  5.  $(x + 8)(x - 10)$  in the expanded form is:  
(a)  $x^2 - 8x - 80$                       (b)  $x^2 - 2x - 80$                       (c)  $x^2 + 2x + 80$                       (d)  $x^2 - 2x + 80$
  6. The value of  $95 \times 96$  is:  
(a) 9020                      (b) 9120                      (c) 9320                      (d) 9340
  7. The value of  $104 \times 96$  is:  
(a) 9984                      (b) 9624                      (c) 9980                      (d) 9986
  8. On dividing  $x^3 + 3x^2 + 3x + 1$  by  $x$  we get remainder:  
(a) 1                      (b) 0                      (c) -1                      (d) 2
  9. If  $x - 2$  is a factor of  $x^3 - 3x + 5a$  then the value of  $a$  is:  
(a) 1                      (b) -1                      (c)  $\frac{2}{5}$                       (d)  $\frac{-2}{5}$
  10. Find the correct identity  
(a)  $(a + b)^2 = a^2 + 2ab + b^2$                       (c)  $(a + b)^2 = a^2 - 2ab + b^2$   
(b)  $(a - b)^2 = a^2 + 2ab + b^2$                       (d)  $(a^2 - b^2) = a^2 + 2ab + b^2$
  11. Factor of  $4p^2 - 9q^2$  are  
(a)  $(4p + 9q)(4p - 9q)$                       (b)  $(2p + 3q)(2p - 3q)$   
(c)  $(2p - 3q)(2p - 3q)$                       (d)  $(4p + 9q)(4p + 9q)$
  12. The value of  $105 \times 95$  is:  
(a) 9925                      (b) 9975                      (c) 9980                      (d) 9990
- .....

**MCQ WORKSHEET-II**  
**CLASS VIII: CHAPTER - 14**  
**FACTORISATION**

1. Find the incorrect mathematical statement.  
(a)  $4(x - 5) = 4x - 20$  (b)  $3x + 2x = 5x^2$   
(c)  $x(3x + 2) = 3x^2 + 2x$  (d)  $2x + 3x = 5x$
2. Factors of  $p^2 + 6p + 8$  are  
(a)  $(p + 2)(p - 4)$  (b)  $(p - 2)(p - 4)$   
(c)  $(p + 2)(p + 4)$  (d)  $(p - 2)(p + 4)$
3. Factors of  $a^2 + 8a + 16$  are:  
(a)  $(a + 4)(a - 4)$  (b)  $(a + 4)(a + 4)$   
(c)  $(a + 4)(4 - a)$  (d)  $(a - 4)(a - 4)$
4. Factors of  $2x + 4$  is  
(a)  $2(x - 4)$  (b)  $2(x + 4)$  (c)  $2(x - 2)$  (d)  $2(x + 2)$
5. Factors of  $5xy + 10x$  is  
(a)  $5x(y + 2)$  (b)  $5y(x + 2)$  (c)  $5x(y - 2)$  (d) none of these
6. Factors of  $12a^2b + 15ab^2$  is  
(a)  $3ab(4a + 5b)$  (b)  $3ab(4a + 15b)$  (c)  $ab(12a + 15b)$  (d) none of these
7. Factors of  $10x^2 - 18x^3 + 14x^4$  is  
(a)  $2x^2(7x^2 - 9x + 5)$  (b)  $x^2(14x^2 - 18x + 10)$  (c)  $2x(7x^3 - 9x^2 + 5x)$  (d) none of these
8. Factors of  $12x + 36$  is  
(a)  $2(6x + 18)$  (b)  $4(3x + 9)$  (c)  $12(x + 3)$  (d) none of these
9. Factors of  $22y - 33z$  is  
(a)  $22y - 33z$  (b)  $11(y - 3z)$  (c)  $11(y - z)$  (d) none of these
10. Factors of  $14pq + 35pqr$  is  
(a)  $pq(14 + 35r)$  (b)  $7pq(2 + 5r)$  (c)  $7pq(14 + 5r)$  (d) none of these
11. Factors of  $2xy + 2y + 3x + 3$  is  
(a)  $(x + 1)(2y + 1)$  (b)  $(x + 1)(2y + 3)$  (c)  $(x + 3)(2y + 1)$  (d) none of these
12. Factors of  $6xy - 4y + 6 - 9x$  is  
(a)  $(3x - 2)(2y + 3)$  (b)  $(3x - 2)(2y - 3)$  (c)  $(3x + 2)(2y - 3)$  (d) none of these
13. Factors of  $7a^2 + 14a$  is  
(a)  $a(7a + 14)$  (b)  $7a(a + 14)$  (c)  $7a(a + 2)$  (d) none of these
14. Factors of  $5x^2y - 15xy^2$  is  
(a)  $xy(5x - 15y)$  (b)  $5xy(x - 3y)$  (c)  $5xy(x - 5y)$  (d) none of these
- .....

**MCQ WORKSHEET-III**  
**CLASS VIII: CHAPTER - 14**  
**FACTORISATION**

1. Factors of  $ax^2y + bxy^2 + cxyz$  is  
(a)  $xy(ax + by + cz)$  (b)  $xyz(ax + by + c)$  (c)  $yz(ax + by + cz)$  (d) none of these
2. Factors of  $x^2 + xy + 8x + 8y$  is  
(a)  $(x + y)(y + 8)$  (b)  $(x + y)(x + 8)$  (c)  $(x + y)(8 + y)$  (d) none of these
3. Factors of  $15xy - 6x + 5y - 2$  is  
(a)  $(5y - 2)(3x + 2)$  (b)  $(5y - 2)(3x + 1)$  (c)  $(5y - 1)(3x + 2)$  (d) none of these
4. Factors of  $ax + bx - ay - by$  is  
(a)  $(a - b)(x + y)$  (b)  $(a + b)(x + y)$  (c)  $(a + b)(x - y)$  (d) none of these
5. Factors of  $15pq + 15 + 9q + 25p$  is  
(a)  $(5p + 3)(3q + 5)$  (b)  $(5p + 3)(q + 5)$  (c)  $(p + 3)(3q + 5)$  (d) none of these
6. Factors of  $z - 7 + 7xy - xyz$  is  
(a)  $(z - 7)(1 - xy)$  (b)  $(z - 7)(xy - 1)$  (c)  $(7 - z)(1 - xy)$  (d) none of these
7. Factors of  $x^2 + 8x + 16$  is  
(a)  $(x + 8)(x + 2)$  (b)  $(x + 4)(x + 2)$  (c)  $(x + 4)(x + 4)$  (d) none of these
8. Factors of  $4y^2 - 12y + 9$  is  
(a)  $(2y - 3)(2y - 6)$  (b)  $(2y - 3)(2y - 3)$  (c)  $(4y - 3)(y - 3)$  (d) none of these
9. Factors of  $49p^2 - 36$  is  
(a)  $(7p - 9)(7p + 4)$  (b)  $(7p + 4)(7p - 9)$  (c)  $(7p - 6)(7p + 6)$  (d) none of these
10. Factors of  $a^2 - 2ab + b^2 - c^2$  is  
(a)  $(a - b - c)(a - b + c)$  (b)  $(a + b - c)(a + b + c)$  (c)  $(a - b + c)(a - b + c)$  (d) none of these
11. Factors of  $m^4 - 256$  is  
(a)  $(m^2 - 16)(m^2 - 16)$  (b)  $(m^2 + 16)(m^2 + 16)$  (c)  $(m^2 + 16)(m^2 - 16)$  (d) none of these
12. Factors of  $x^2 + 5x + 6$  is  
(a)  $(x + 3)(x + 2)$  (b)  $(x + 4)(x + 2)$  (c)  $(x + 6)(x + 1)$  (d) none of these
13. Factors of  $x^2 - 25$  is  
(a)  $(x - 1)(x - 25)$  (b)  $(x - 1)(x + 25)$  (c)  $(x - 5)(x - 5)$  (d)  $(x - 5)(x + 5)$
14. Factors of  $36 - 9x^2$  will be  
(a)  $(6 + 3x)(6 - 3x)$  (b)  $(3x - 6)(6 - 3x)$  (c)  $(3x + 6)(3x - 6)$  (d)  $(12x - 3x)(3 + 3x)$
15. Square of  $\left(x - \frac{1}{x}\right)$  will be  
(a)  $x^2 - 2 - \frac{1}{x^2}$  (b)  $x^2 - 2 + \frac{1}{x^2}$  (c)  $x^2 - 4 - \frac{1}{x^2}$  (d)  $x^2 - 2 + \frac{1}{x}$



**MCQ WORKSHEET-IV**  
**CLASS VIII: CHAPTER - 14**  
**FACTORISATION**

1. Factors of  $a^2 + bc + ab + ac$  is  
(a)  $(a + b)(b + c)$       (b)  $(a + b)(a + c)$       (c)  $(a + c)(c + b)$       (d) none of these
2. Factors of  $ax^2 + by^2 + bx^2 + ay^2$  is  
(a)  $(a^2 + b^2)(x^2 + y^2)$       (b)  $(a^2 + b^2)(x + y)$       (c)  $(a + b)(x^2 + y^2)$       (d) none of these
3. Factors of  $1 + a + ac + a^2c$  is  
(a)  $(1 + a)(1 + ac)$       (b)  $(1 + a)(a + c)$       (c)  $(a + c)(1 + ac)$       (d) none of these
4. Factors of  $xy - pq + qy - px$  is  
(a)  $(p - y)(x + q)$       (b)  $(y - p)(x + q)$       (c)  $(y + p)(x + q)$       (d) none of these
5. Factors of  $ab(x^2 + y^2) + xy(a^2 + b^2)$  is  
(a)  $(ax + b)(bx + ay)$       (b)  $(ax + by)(bx + ay)$       (c)  $(a^2 + b^2)(x^2 + y^2)$       (d) none of these
6. Factors of  $49x^2 - 16y^2$  is  
(a)  $(7x - 4y)(7x + 4y)$       (b)  $(7x - 4y)(7x - 4y)$       (c)  $(7x + 4y)(7x + 4y)$       (d) none of these
7. Factors of  $48a^2 - 243b^2$  is  
(a)  $(4a - 9b)(4a + 9b)$       (b)  $(4a - 9b)(4a - 9b)$       (c)  $(4a + 9b)(4a + 9b)$       (d) none of these
8. Factors of  $4x^2 - y^2 + 6y - 9$  is  
(a)  $(2x + y - 3)(2x - y - 3)$       (b)  $(2x + y - 3)(2x - y + 3)$   
(c)  $(2x + y + 3)(2x - y - 3)$       (d) none of these
9. Evaluate  $(502)^2 - (498)^2$  using suitable identity.  
(a) 3000      (b) 4000      (c) 5000      (d) 6000
10. Evaluate  $(8.6)^2 - (1.4)^2$  using suitable identity.  
(a) 72      (b) 100      (c) 144      (d) none of these
11. Factors of  $x^2 + 10x + 25$  is  
(a)  $(x + 5)(x + 2)$       (b)  $(x + 5)(x + 5)$       (c)  $(x + 20)(x + 5)$       (d) none of these
12. Factors of  $x^2 + 8x + 15$  is  
(a)  $(x + 3)(x + 5)$       (b)  $(x + 15)(x + 1)$       (c)  $(x + 10)(x + 5)$       (d) none of these
13. Factors of  $x^2 - 7x + 12$  is  
(a)  $(x + 3)(x + 4)$       (b)  $(x + 3)(x - 4)$       (c)  $(x - 3)(x - 4)$       (d) none of these
14. Factors of  $x^2 + x - 56$  is  
(a)  $(x + 8)(x + 7)$       (b)  $(x + 8)(x - 7)$       (c)  $(x - 8)(x + 7)$       (d)  $(x - 8)(x - 7)$
15. Factors of  $x^2 + 10x + 24$  is  
(a)  $(x + 4)(x + 6)$       (b)  $(x + 12)(x + 2)$       (c)  $(x + 8)(x + 3)$       (d) none of these

**PRACTICE QUESTIONS**  
**CLASS VIII: CHAPTER - 14**  
**FACTORISATION**

1. Factorize  $12a^2b + 15ab^2$
2. Factorize  $10x^2 - 18x^3 + 14x^4$
3. Factorize: (i)  $12x + 36$  (ii)  $22y - 33z$  (iii)  $14pq + 35pqr$
4. Factorize  $6xy - 4y + 6 - 9x$ .
5. Factorize  $x^2 + 8x + 16$
6. Factorize  $4y^2 - 12y + 9$
7. Factorize  $49p^2 - 36$
8. Factorize  $a^2 - 2ab + b^2 - c^2$
9. Factorize  $m^4 - 256$
10. Factorize  $x^2 + 5x + 6$
11. Find the factors of  $y^2 - 7y + 12$ .
12. Obtain the factors of  $z^2 - 4z - 12$ .
13. Find the factors of  $3m^2 + 9m + 6$ .
14. Do the following divisions. (i)  $-20x^4 \div 10x^2$  (ii)  $7x^2y^2z^2 \div 14xyz$
15. Divide  $24(x^2yz + xy^2z + xyz^2)$  by  $8xyz$
16. Divide  $44(x^4 - 5x^3 - 24x^2)$  by  $11x(x - 8)$
17. Divide  $z(5z^2 - 80)$  by  $5z(z + 4)$
18. Factorize the expressions and divide them as directed.
  - (i)  $(y^2 + 7y + 10) \div (y + 5)$
  - (ii)  $(m^2 - 14m - 32) \div (m + 2)$
  - (iii)  $(5p^2 - 25p + 20) \div (p - 1)$
  - (iv)  $4yz(z^2 + 6z - 16) \div 2y(z + 8)$
  - (v)  $12xy(9x^2 - 16y^2) \div 4xy(3x + 4y)$
  - (vi)  $39y^3(50y^2 - 98) \div 26y^2(5y + 7)$
19. Divide as directed.
  - (i)  $5(2x + 1)(3x + 5) \div (2x + 1)$
  - (ii)  $26xy(x + 5)(y - 4) \div 13x(y - 4)$
  - (iii)  $52pqr(p + q)(q + r)(r + p) \div 104pq(q + r)(r + p)$
  - (iv)  $20(y + 4)(y^2 + 5y + 3) \div 5(y + 4)$
  - (v)  $x(x + 1)(x + 2)(x + 3) \div x(x + 1)$

20. Find and correct the errors in the following mathematical statements.

(i).  $4(x - 5) = 4x - 5$

(ii).  $x + 2x + 3x = 5x$

(iii).  $5y + 2y + y - 7y = 0$

(iv).  $(a - 4)(a - 2) = a^2 - 8$

(v).  $(a + 4)(a + 2) = a^2 + 8$

(vi).  $\frac{3x^2 + 1}{3x^2} = 1 + 1 = 2$

(vii).  $\frac{3x}{3x + 2} = \frac{1}{2}$

(viii).  $\frac{7x + 5}{5} = 7x$

21. Factorize the following expressions:

1.  $9x^2 + 12xy$

2.  $18x^2y - 24xyz$

3.  $27a^3b^3 - 45a^4b^2$

4.  $2a(x + y) - 3b(x + y)$

5.  $2x(p^2 + q^2) + 4y(p^2 + q^2)$

6.  $x(a - 5) + y(5 - a)$

7.  $4(a + b) - 6(a + b)^2$

8.  $8(3a - 2b)^2 - 10(3a - 2b)$

9.  $x(x + y)^3 - 3x^2y(x + y)$

10.  $x^3 + 2x^2 + 5x + 10$

11.  $x^2 + xy - 2xz - 2yz$

12.  $a^3b - a^2b + 5ab - 5b$

13.  $8 - 4a - 2a^3 + a^4$

14.  $x^3 - 2x^2y + 3xy^2 - 6y^3$

15.  $px - 5q + pq - 5x$

16.  $x^2 + y - xy - x$

17.  $(3a - 1)^2 - 6a + 2$

18.  $(2x - 3)^2 - 8x + 12$

19.  $a^3 + a - 3a^2 - 3$

20.  $3ax - 6ay - 8by + 4bx$

21.  $abx^2 + a^2x + b^2x + ab$

22.  $x^3 - x^2 + ax + x - a - 1$

23.  $2x + 4y - 8xy - 1$

24.  $ab(x^2 + y^2) - xy(a^2 + b^2)$

25.  $a^2 + ab(b + 1) + b^3$

**HOT'S QUESTIONS**  
**CLASS VIII: CHAPTER - 14**  
**FACTORISATION**

1. Factorize the following expressions by grouping:

26.  $x^3 - x^2 + ax + x - a - 1$

27.  $2x + 4y - 8xy - 1$

28.  $ab(x^2 + y^2) - xy(a^2 + b^2)$

29.  $a^2 + ab(b + 1) + b^3$

30.  $ab + bc + ax + cx$

31.  $x^2 + 3x + x + 3$

32.  $6ab - b^2 + 12ac - 2bc$

33.  $a^2 + b - ab - a$

34.  $a(a + b - c) - bc$

35.  $a^3 + a - 3a^2 - 3$

2. Factorize the following expressions using suitable identity:

1.  $25x^2 - 64y^2$

2.  $100 - 9x^2$

3.  $5x^2 - 7y^2$

4.  $(3x + 5y)^2 - 4z^2$

5.  $150 - 6x^2$

6.  $20x^2 - 45$

7.  $3x^3 - 48x$

8.  $2 - 50x^2$

9.  $27a^2 - 48b^2$

10.  $x - 64x^3$

11.  $8ab^2 - 18a^3$

12.  $3a^3b - 243ab^3$

13.  $(a + b)^3 - a - b$

14.  $108a^2 - 3(b - c)^2$

15.  $x^3 - 5x^2 - x + 5$

16.  $a^2 + 2ab + b^2 - 9c^2$

17.  $9 - a^2 + 2ab - b^2$

18.  $a^2 - b^2 - 4ac + 4c^2$

19.  $9a^2 + 3a - 8b - 64b^2$

20.  $x^2 - y^2 + 6y - 9$

21.  $4x^2 - 9y^2 - 2x - 3y$

22.  $x^4 - 1$

23.  $a - b - a^2 + b^2$

24.  $x^4 - 625$

25.  $x^4 - 81$

3. Factorize the following expressions:

1.  $x^2 + 11x + 30$

2.  $x^2 + 18x + 32$

3.  $x^2 + 7x - 18$

4.  $x^2 + 5x - 6$

5.  $y^2 - 4y + 3$

6.  $x^2 - 21x + 108$

7.  $x^2 - 11x - 80$

8.  $x^2 - x - 156$

9.  $z^2 - 32z - 105$

10.  $40 + 3x - x^2$

11.  $6 - x - x^2$

12.  $7x^2 + 49x + 84$

13.  $m^2 + 17mn - 84n^2$

14.  $5x^2 + 16x + 3$

15.  $6x^2 + 17x + 12$

16.  $9x^2 + 18x + 8$

17.  $14x^2 + 9x + 1$

18.  $2x^2 + 3x - 90$

19.  $2x^2 + 11x - 21$

20.  $3x^2 - 14x + 8$

21.  $18x^2 + 3x - 10$

22.  $15x^2 + 2x - 8$

23.  $6x^2 + 11x - 10$

24.  $30x^2 + 7x - 15$

25.  $24x^2 - 41x + 12$

26.  $2x^2 - 7x - 15$

27.  $6x^2 + 11x - 10$

28.  $10x^2 - 9x - 7$

29.  $5x^2 - 16x - 21$

30.  $2x^2 - x - 21$

31.  $15x^2 - x - 28$

32.  $8a^2 - 27ab + 9b^2$

33.  $5x^2 + 33xy - 14y^2$

34.  $3x^3 - x^2 - 10x$

35.  $x^2 + 9x + 18$

36.  $x^2 + 5x - 24$

37.  $x^2 - 4x - 21$

38.  $6x^2 + 7x - 3$

39.  $2x^2 - 7x - 39$

40.  $9x^2 - 22x + 8$

4. Factorize the following expressions:

1.  $5(3x + y)^2 + 6(3x + y) - 8$

2.  $2(x + y)^2 - 9(x + y) - 5$

3.  $9(2a - b)^2 - 4(2a - b) - 13$

4.  $7(x - 2y)^2 - 25(x - 2y) + 12$

5.  $2(x - y)^2 - (x - y) - 21$

6.  $6(2x - y)^2 + 11(2x - y) - 10$

7.  $10(p + q)^2 - 9(p + q) - 7$

8.  $2(a + b)^2 - 7(a + b) - 15$

9.  $9(a + b - c)^2 - 22(a + b - c) + 8$

10.  $4x^4 + 7x^2 - 2$

11.  $x^4 + 11x^2 + 30$

12.  $x^4 - 3x^2 + 2.$

13.  $y^4 - 4y^2 + 3$

14.  $3x^4 - 14x^2 + 8$

15.  $x^4 + 7x^2 - 18$

5. Divide the polynomial  $2x^4 + 8x^3 + 7x^2 + 4x + 3$  by  $x + 3$ .

6. Divide the polynomial  $x^3 - 6x^2 + 11x - 6$  by  $x^2 - 4x + 3$

7. Divide the polynomial  $10x^4 + 17x^3 - 62x^2 + 30x - 3$  by  $2x^2 + 7x - 1$ .

8. Using division show that  $3x^2 + 5$  is factor of  $6x^5 + 15x^4 + 16x^3 + 4x^2 + 10x - 35$ .

9. What must be subtracted from  $8x^4 + 14x^3 - 2x^2 + 7x - 8$  so that the resulting polynomial is exactly divisible by  $4x^2 + 3x - 2$ ?

10. Find the values of a and b so that  $x^4 + x^3 + 8x^2 + ax + b$  is divisible by  $x^2 + 1$ .

11. Divide  $15x^4 + 16x^3 + \frac{10}{3}x - 9x^2 - 6$  by  $3x - 2$ . Write down the coefficients of the terms in the quotient.

12. Find the value of a, if  $x + 2$  is a factor of  $4x^4 + 2x^3 - 3x^2 + 8x + 5a$ .

13. What must be added to  $x^4 + 2x^3 - 2x^2 + x - 1$  so that the resulting polynomial is exactly divisible by  $x^2 + 2x - 3$ ?

14. Divide:  $6x^3 + 11x^2 - 39x - 65$  by  $3x^2 + 13x + 13$ .

15. Divide:  $30x^4 + 11x^3 - 82x^2 - 12x + 48$  by  $3x^2 + 2x - 4$ .

.....

**MCQ WORKSHEET-I**  
**CLASS VIII: CHAPTER - 15**  
**INTRODUCTION TO GRAPH**

1. The coordinate of A in the below graph is  
(a)  $(-7, 3)$       (b)  $(7, -7)$       (c)  $(-6, -1)$       (d)  $(2, -3)$
2. The coordinate of B in the below graph is  
(a)  $(-7, 3)$       (b)  $(7, -7)$       (c)  $(-6, -1)$       (d)  $(2, -3)$
3. The coordinate of C in the below graph is  
(a)  $(-7, 3)$       (b)  $(7, -7)$       (c)  $(-6, -1)$       (d)  $(2, -3)$
4. The coordinate of D in the below graph is  
(a)  $(-7, 3)$       (b)  $(7, -7)$       (c)  $(-6, -1)$       (d)  $(2, -3)$

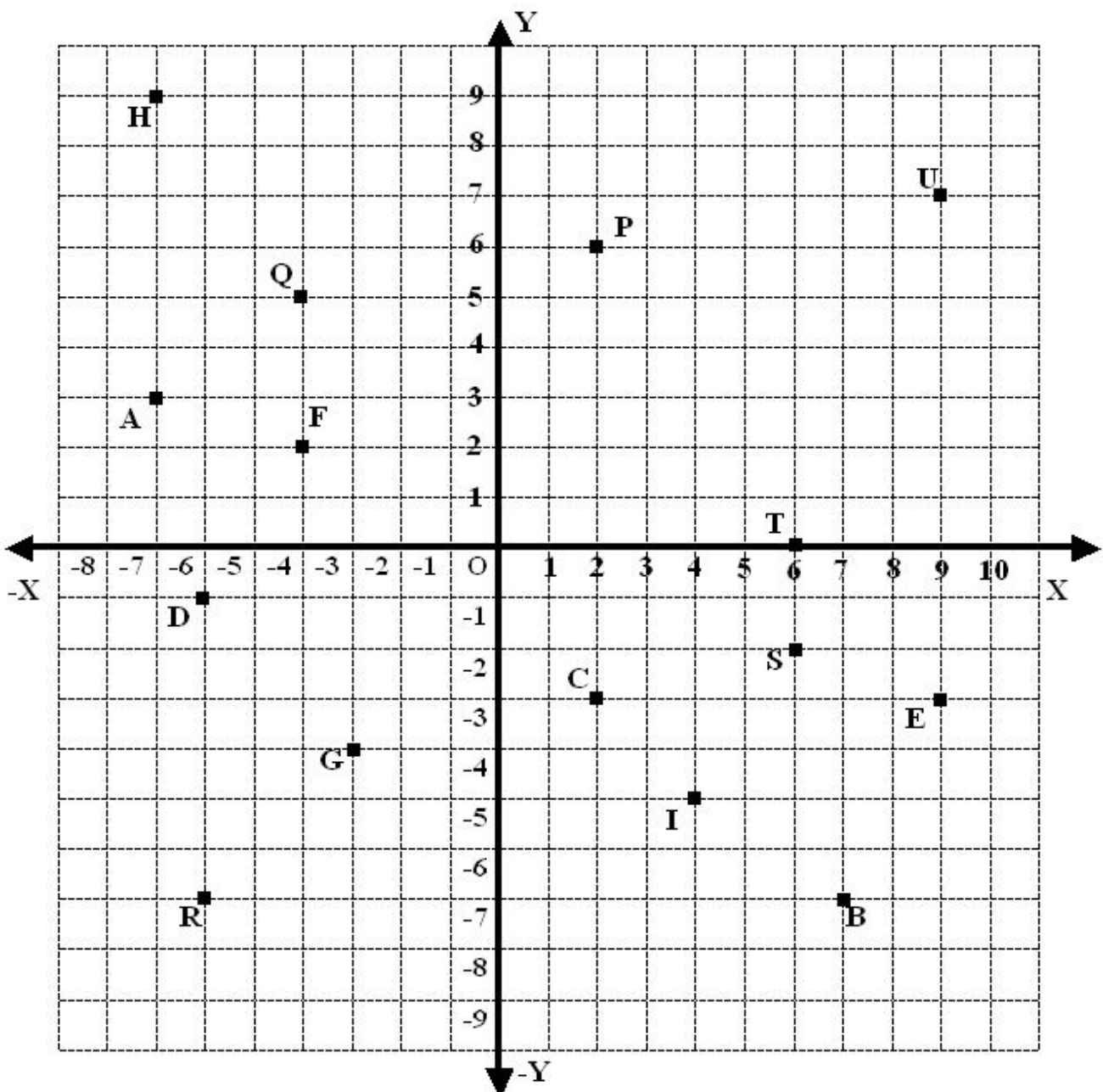

5. The coordinate of E in the given graph is  
(a) (9, -3)      (b) (-4, 2)      (c) (-3, -4)      (d) (-7, 9)
6. The coordinate of F in the given graph is  
(a) (9, -3)      (b) (-4, 2)      (c) (-3, -4)      (d) (-7, 9)
7. The coordinate of G in the given graph is  
(a) (9, -3)      (b) (-4, 2)      (c) (-3, -4)      (d) (-7, 9)
8. The coordinate of H in the given graph is  
(a) (9, -3)      (b) (-4, 2)      (c) (-3, -4)      (d) (-7, 9)
9. The coordinate of P in the given graph is  
(a) (2, 6)      (b) (-6, -7)      (c) (6, -2)      (d) (6, 0)
10. The coordinate of S in the given graph is  
(a) (2, 6)      (b) (-6, -7)      (c) (6, -2)      (d) (6, 0)
11. The coordinate of R in the given graph is  
(a) (2, 6)      (b) (-6, -7)      (c) (6, -2)      (d) (6, 0)
12. The coordinate of T in the given graph is  
(a) (2, 6)      (b) (-6, -7)      (c) (6, -2)      (d) (6, 0)
13. The coordinate of U in the given graph is  
(a) (9, 7)      (b) (-4, 5)      (c) (4, -5)      (d) none of these
14. The coordinate of I in the given graph is  
(a) (9, 7)      (b) (-4, 5)      (c) (4, -5)      (d) none of these
15. The coordinate of Q in the given graph is  
(a) (9, 7)      (b) (-4, 5)      (c) (4, -5)      (d) none of these
- .....



**MCQ WORKSHEET-II**  
**CLASS VIII: CHAPTER - 15**  
**INTRODUCTION TO GRAPH**

1. If  $y$  – coordinate of a point is zero, then this point always lies:  
(a) I quadrant      (b) II quadrant      (c)  $x$  – axis      (d)  $y$  – axis
2. If  $x$  – coordinate of a point is zero, then this point always lies:  
(a) I quadrant      (b) II quadrant      (c)  $x$  – axis      (d)  $y$  – axis
3. Point  $(-6, 4)$  lies in the quadrant:  
(a) I      (b) II      (c) III      (d) IV
4. The point  $(-4, -3)$  means:  
(a)  $x = -4, y = -3$       (b)  $x = -3, y = -4$       (c)  $x = 4, y = 3$       (d) None of these
5. Point  $(0, 4)$  lies on the:  
(a) I quadrant      (b) II quadrant      (c)  $x$  – axis      (d)  $y$  – axis
6. Point  $(5, 0)$  lies on the:  
(a) I quadrant      (b) II quadrant      (c)  $x$  – axis      (d)  $y$  – axis
7. On joining points  $(0, 0), (0, 2), (2,2)$  and  $(2, 0)$  we obtain a:  
(a) Square      (b) Rectangle      (c) Rhombus      (d) Parallelogram
8. Point  $(-2, 3)$  lies in the:  
(a) I quadrant      (b) II quadrant      (c) III quadrant      (d) IV quadrant
9. Point  $(0, -2)$  lies:  
(a) on the  $x$ -axis      (b) in the II quadrant      (c) on the  $y$ -axis      (d) in the IV quadrant
10. Abscissa of the all the points on  $x$  – axis is:  
(a) 0      (b) 1      (c)  $-1$       (d) any number
11. Ordinate of the all the points on  $x$  – axis is:  
(a) 0      (b) 1      (c)  $-1$       (d) any number
12. Abscissa of the all the points on  $y$  – axis is:  
(a) 0      (b) 1      (c)  $-1$       (d) any number
13. Ordinate of the all the points on  $y$  – axis is:  
(a) 0      (b) 1      (c)  $-1$       (d) any number
14. The point whose ordinate is 4 and which lies on  $y$  – axis is:  
(a)  $(4, 0)$       (b)  $(0, 4)$       (c)  $(1, 4)$       (d)  $(4, 2)$
15. The perpendicular distance of the point  $P(3,4)$  from the  $y$  – axis is:  
(a) 3      (b) 4      (c) 5      (d) 7

**PRACTICE QUESTIONS**  
**CLASS VIII: CHAPTER - 15**  
**INTRODUCTION TO GRAPH**

- Which of the following points lie in I and II quadrants?  
 (1, 1), (2, -3), (-2, 3), (-1, 1), (-3, -2), (4, 3)
- Which of the following points lie on (a)  $x$ -axis (b)  $y$ -axis?  
 (5, 1), (8, 0), (0, 4), (-3, 0), (0, -3), (0, 5), (0, 0)
- If the  $x$ -coordinate of a point is negative, it can lie in which quadrants?
- From the figure, write the coordinates of the points P, Q, R and S. Does the line joining P and Q pass through origin?

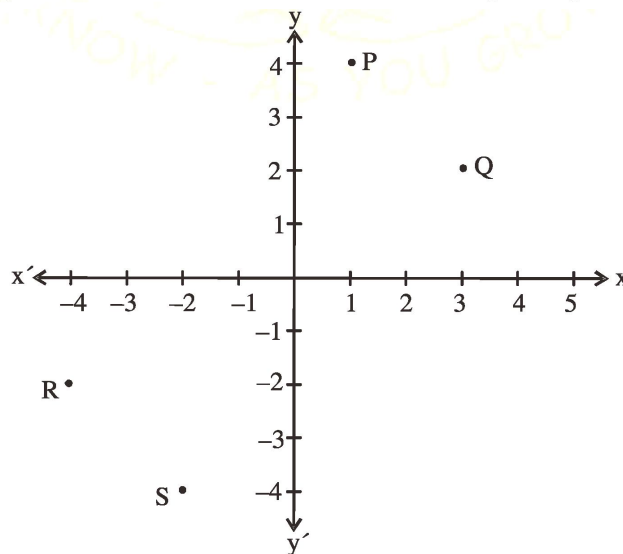

- Write the coordinates of the following points:
  - lying on both axes
  - lying on  $x$ -axis and with  $x$ -coordinate 4
  - lying on  $y$ -axis with  $y$ -coordinate -3
- The coordinates of the three vertices of a rectangle ABCD are A(3, 2), B (-4, 2), C(-4,5). Plot these points and write the coordinates of D.
- ABC is an equilateral triangle as shown in the figure. Find the coordinates of its vertices

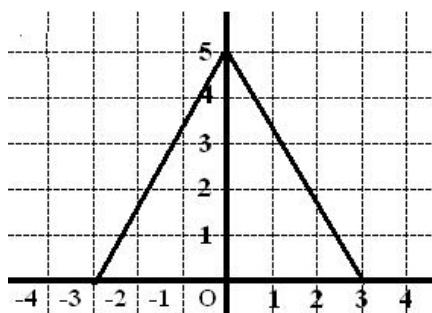

- Plot the following points on a graph paper:

$x$	1	2	3	4	5
$y$	5	8	11	14	17

Join these points. What do you observe ?

- What is the name of horizontal and the vertical lines drawn to determine the position of any point in the Cartesian plane?

10. What is the name of each part of the plane formed by these two lines?
11. Write the name of the point where these two lines intersect.
12. Locate the points (5, 0), (0, 5), (2, 5), (5, 2), (-3, 5), (-3, -5), (5, -3) and (6, 1) in the Cartesian plane.
13. Plot the following ordered pairs of number (x, y) as points in the Cartesian plane. Use the scale 1cm = 1 unit on the axes.

<b>x</b>	-3	0	-1	4	2
<b>y</b>	7	-3.5	-3	4	-3

14. In which quadrant or on which axis do each of the points (-2, 4), (3, -1), (-1, 0), (1, 2) and (-3, -5) lie? Verify your answer by locating them on the Cartesian plane.
15. Plot the points (x, y) given in the following table on the plane, choosing suitable units of distance on the axes.

<b>x</b>	-1	2	-4	2	-3
<b>y</b>	0	-5	2	1	2

16. Plot the following points and verify if they lie on a line. If they lie on a line, name it.
- (i) (0, 2), (0, 5), (0, 6), (0, 3.5)                      (ii) A (1, 1), B (1, 2), C (1, 3), D (1, 4)
- (iii) K (1, 3), L (2, 3), M (3, 3), N (4, 3)              (iv) W (2, 6), X (3, 5), Y (5, 3), Z (6, 2)
17. Draw the line passing through (2, 3) and (3, 2). Find the coordinates of the points at which this line meets the x-axis and y-axis.
18. Plot the following points on a graph sheet. Verify if they lie on a line
- (a) A(4, 0), B(4, 2), C(4, 6), D(4, 2.5)
- (b) P(1, 1), Q(2, 2), R(3, 3), S(4, 4)
- (c) K(2, 3), L(5, 3), M(5, 5), N(2, 5)
19. In which quadrant or on which axis do each of the points (5, 0), (0, 5), (2, 5), (5, 2), (-3, 5), (-3, -5), (5, -3) and (6, 1) in the Cartesian plane.
20. Plot the points A (4, 4) and (-4, 4) on a graph sheet. Join the lines OA, OB and BA. What figure do you obtain.
21. The given graph describes the distances of a car from a city P at different times when it is travelling from City P to City Q, which are 350 km apart. Study the graph and answer the following:
- (i) What information is given on the two axes?
- (ii) From where and when did the car begin its journey?
- (iii) How far did the car go in the first hour?
- (iv) How far did the car go during (i) the 2nd hour? (ii) the 3rd hour?
- (v) Was the speed same during the first three hours? How do you know it?
- (vi) Did the car stop for some duration at any place? Justify your answer.
- (vii) When did the car reach City Q?

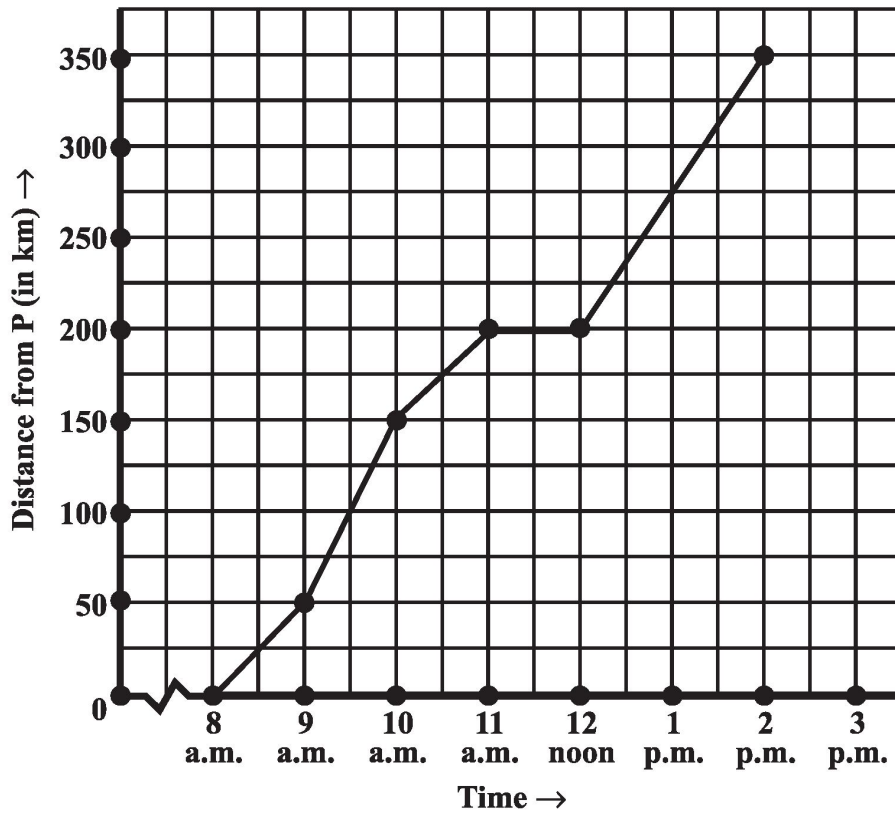

22. The following line graph shows the yearly sales figures for a manufacturing company.

- What were the sales in (i) 2002 (ii) 2006?
- What were the sales in (i) 2003 (ii) 2005?
- Compute the difference between the sales in 2002 and 2006.
- In which year was there the greatest difference between the sales as compared to its previous year?

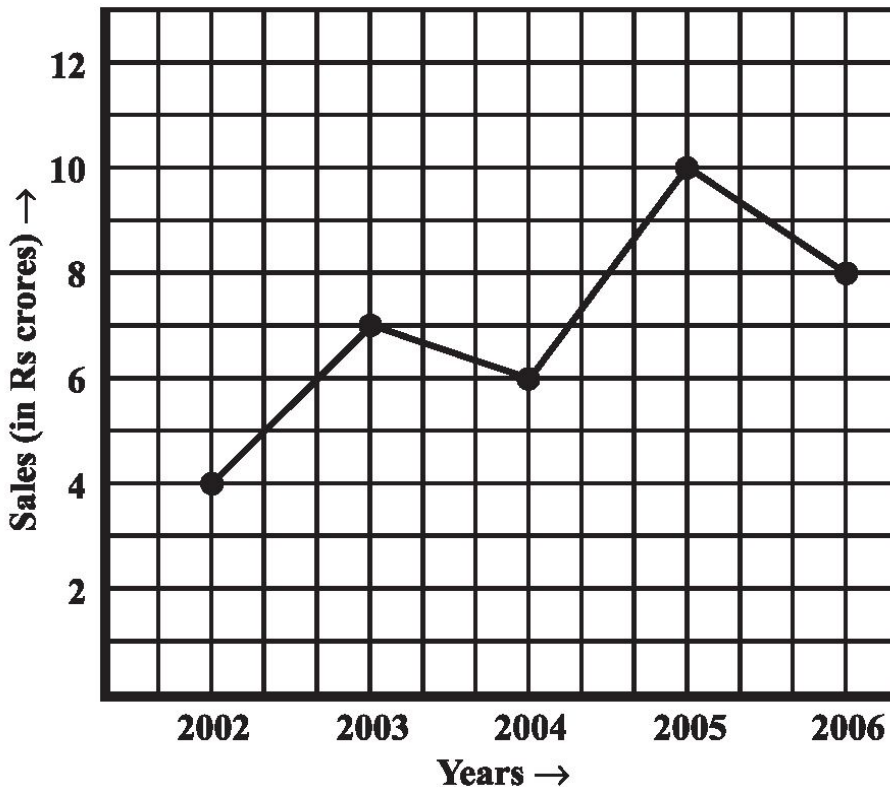

23. Use the tables below to draw linear graphs.

(a) The number of days a hill side city received snow in different years.

<b>Year</b>	2003	2004	2005	2006
<b>Days</b>	8	10	5	12

(b) Population (in thousands) of men and women in a village in different years.

<b>Year</b>	2003	2004	2005	2006	2007
<b>Number of Men</b>	12	12.5	13	13.2	13.5
<b>Number of Women</b>	11.3	11.9	13	13.6	12.8

24. Plot the point (4, 3) on a graph sheet. Is it the same as the point (3, 4)?

25. The following table gives the quantity of petrol and its cost. Plot a graph to show the data.

<b>No. of litres of petrol</b>	10	15	20	25
<b>Cost of petrol in Rs.</b>	500	750	1000	1250

26. A bank gives 10% Simple Interest (S.I.) on deposits by senior citizens. Draw a graph to illustrate the relation between the sum deposited and simple interest earned. Find from your graph

(a) the annual interest obtainable for an investment of Rs 250.

(b) the investment one has to make to get an annual simple interest of Rs 70.

27. Ajit can ride a scooter constantly at a speed of 30 kms/hour. Draw a time-distance graph for this situation. Use it to find

(i) the time taken by Ajit to ride 75 km. (ii) the distance covered by Ajit in  $3\frac{1}{2}$  hours.

28. Draw the graphs for the following table of values, with suitable scales on the axes.

<b>Time (in hours)</b>	6 am	7 am	8 am	9 am
<b>Distances (in km)</b>	40	80	120	160

Distance travelled by a car

(i) How much distance did the car cover during the period 7.30 a.m. to 8 a.m.?

(ii) What was the time when the car had covered a distance of 100 km since it's start?

.....

**HOT'S QUESTIONS**  
**CLASS VIII: CHAPTER - 15**  
**INTRODUCTION TO GRAPH**

1. Draw the graph of  $y = 3x$ . From the graph, find the value of  $y$  when (i)  $x = 4$  and (ii)  $x = 5$ .
2. Consider the relation between the perimeter and the side of a square, given by  $P = 4a$ . Draw a graph to show this relation. From the graph, find the value of  $P$  when (i)  $a = 4$  and (ii)  $a = 5$ .
3. Consider the relation between the area and the side of a square, given by  $A = x^2$ . Draw a graph to show this relation. From the graph, find the value of  $P$  when  $x = 4$ .
4. Simple interest on a certain sum is Rs. 40 per year then  $S = 40x$ , where  $x$  is the number of years. Draw a graph of this relation. From the graph, find the value of  $S$  when (i)  $x = 5$  and (ii)  $x = 6$ .
5. Consider the relation between the perimeter and the side of a regular pentagon, given by  $P = 5a$ . Draw a graph to show this relation. From the graph, find the value of  $P$  when (i)  $a = 4$  and (ii)  $a = 5$ .
6. Plot each of the following points  $A(2, 3)$ ,  $B(5, 3)$ ,  $C(5, 5)$  and  $D(2, 5)$ . Join the points in order then write the figure obtained.
7. Plot any three points such that  $x$ -coordinates of each points is equal to its  $y$ -coordinates. Join these points in pairs. Do they lie on a line passing through the origin?
8. Plot the points  $A(5, 5)$  and  $(-5, 5)$  on a graph sheet. Join the lines  $OA$ ,  $OB$  and  $BA$ . Name the figure obtained and find the area of the figure so obtained
9. Plot the points  $(0, 2)$ ,  $(3, 0)$ ,  $(-3, 0)$  and  $(0, -2)$  in the graph sheet. Join these points. Name the figure obtained and find the area of the figure so obtained.
10. From below figure, find the coordinates of the points  $A, B, C, D, E$  and  $F$ . What of the points are mirror images in (i)  $x$  – axis (ii)  $y$  – axis.

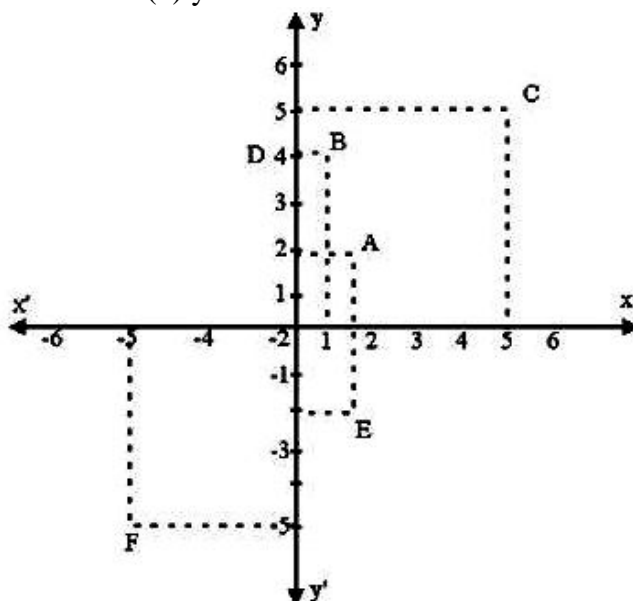

**MCQ WORKSHEET-I**  
**CLASS VIII: CHAPTER - 16**  
**PLAYING WITH NUMBERS**

1. If  $31z6$  is a multiple of 9 then the value of  $z$  is  
(a) 0                                      (b) 4                                      (c) 8                                      (d) 9
2. Which of the following is divisible by 3?  
(a) 15287                                      (b) 15267                                      (c) 15286                                      (d) 152638
3. If  $1A \times A = 9A$ , then what is the value of  $A$ ?  
(a) 3                                      (b) 5                                      (c) 6                                      (d) 2
4. If  $BA \times B3 = 57A$ , then the value of  $A$  and  $B$  is:  
(a)  $A = 5, B = 2$                                       (b)  $A = 2, B = 5$                                       (c)  $A = 5, B = 3$                                       (d)  $A = 3, B = 5$
5. If  $A1 + 1B = B0$ , then the value of  $A$  and  $B$  is:  
(a)  $A = 7, B = 9$                                       (b)  $A = 0, B = 1$                                       (c)  $A = 1, B = 0$                                       (d)  $A = 9, B = 7$
6. If  $37 + AB = 9A$ , then the value of  $A$  and  $B$  is:  
(a)  $A = 5, B = 8$                                       (b)  $A = 2, B = 5$                                       (c)  $A = 7, B = 9$                                       (d)  $A = 4, B = 7$
7. If  $AB + 37 = 6A$ , then the value of  $A$  and  $B$  is:  
(a)  $A = 5, B = 8$                                       (b)  $A = 2, B = 5$                                       (c)  $A = 7, B = 9$                                       (d)  $A = 4, B = 7$
8. If  $A1 + 1B = B0$ , then the value of  $A$  and  $B$  is:  
(a)  $A = 5, B = 8$                                       (b)  $A = 2, B = 5$                                       (c)  $A = 7, B = 9$                                       (d)  $A = 4, B = 7$
9. If  $2AB + AB1 = B18$ , then the value of  $A$  and  $B$  is:  
(a)  $A = 5, B = 8$                                       (b)  $A = 2, B = 5$                                       (c)  $A = 7, B = 9$                                       (d)  $A = 4, B = 7$
10. If  $12A + 6AB = A09$ , then the value of  $A$  and  $B$  is:  
(a)  $A = 8, B = 1$                                       (b)  $A = 2, B = 5$                                       (c)  $A = 7, B = 9$                                       (d)  $A = 4, B = 7$
11. If  $AB7 + 7AB = 98A$ , then the value of  $A$  and  $B$  is:  
(a)  $A = 8, B = 1$                                       (b)  $A = 2, B = 5$                                       (c)  $A = 7, B = 9$                                       (d)  $A = 4, B = 7$
12. If  $AB \times 6 = BBB$ , then the value of  $A$  and  $B$  is:  
(a)  $A = 7, B = 4$                                       (b)  $A = 0, B = 1$                                       (c)  $A = 1, B = 0$                                       (d)  $A = 9, B = 7$
13. If  $B9 + 4A = 65$ , then the value of  $A$  and  $B$  is:  
(a)  $A = 8, B = 1$                                       (b)  $A = 6, B = 1$                                       (c)  $A = 7, B = 9$                                       (d)  $A = 4, B = 7$
14. If  $A + A + A = BA$ , then the value of  $A$  and  $B$  is:  
(a)  $A = 5, B = 2$                                       (b)  $A = 2, B = 5$                                       (c)  $A = 5, B = 1$                                       (d)  $A = 3, B = 5$
15. If  $8A5 + 94A = 1A33$ , then what is the value of  $A$ ?  
(a) 0                                      (b) 4                                      (c) 8                                      (d) 9

**MCQ WORKSHEET-II**  
**CLASS VIII: CHAPTER - 16**  
**PLAYING WITH NUMBERS**

1. If  $24a$  is a multiple of 9 then the value of  $a$  is  
(a) 0                      (b) 3                      (c) 8                      (d) 9
2. If  $21y5$  is a multiple of 9, where  $y$  is a digit then the value of  $y$  is  
(a) 0                      (b) 3                      (c) 1                      (d) 9
3. If  $2y25$  is a multiple of 9, where  $y$  is a digit then the value of  $y$  is  
(a) 0                      (b) 3                      (c) 1                      (d) 2
4. If  $24a$  is a multiple of 3, where  $a$  is a digit then the value of  $a$  is  
(a) 0                      (b) 1                      (c) 2                      (d) none of these
5. If  $24y5$  is a multiple of 3, where  $y$  is a digit then the value of  $y$  is  
(a) 0                      (b) 1                      (c) 2                      (d) none of these
6. If  $31y5$  is a multiple of 3, where  $y$  is a digit then the value of  $y$  is  
(a) 0                      (b) 1                      (c) 2                      (d) none of these
7. If  $24y$  is a multiple of 6, where  $y$  is a digit then the value of  $y$  is  
(a) 0                      (b) 1                      (c) 2                      (d) none of these
8. If  $21y8$  is a multiple of 6, where  $y$  is a digit then the value of  $y$  is  
(a) 0                      (b) 1                      (c) 2                      (d) none of these
9. If  $13y4$  is a multiple of 6, where  $y$  is a digit then the value of  $y$  is  
(a) 0                      (b) 1                      (c) 2                      (d) none of these
10. If  $24x$  is a multiple of 11, where  $x$  is a digit then the value of  $x$  is  
(a) 0                      (b) 1                      (c) 2                      (d) none of these
11. If  $2y5$  is a multiple of 11, where  $y$  is a digit then the value of  $y$  is  
(a) 7                      (b) 4                      (c) 2                      (d) none of these
12. If  $31y$  is a multiple of 11, where  $y$  is a digit then the value of  $y$  is  
(a) 7                      (b) 8                      (c) 9                      (d) none of these
13. If  $35a64$  is divisible by 3, where  $a$  is a digit then the value of  $a$  is  
(a) 0                      (b) 1                      (c) 2                      (d) none of these
14. If  $18y71$  is divisible by 3, where  $y$  is a digit then the value of  $y$  is  
(a) 0                      (b) 1                      (c) 2                      (d) none of these
15. If  $66784y$  is divisible by 9, where  $y$  is a digit then the value of  $y$  is  
(a) 0                      (b) 3                      (c) 1                      (d) none of these



**PRACTICE QUESTIONS**  
**CLASS VIII: CHAPTER - 16**  
**PLAYING WITH NUMBERS**

- Write the following numbers in generalised form.  
(i) 25 (ii) 73 (iii) 129 (iv) 302
- Write the following in the usual form.  
(i)  $10 \times 5 + 6$  (ii)  $100 \times 7 + 10 \times 1 + 8$  (iii)  $100 \times a + 10 \times c + b$

- Find Q in the addition.

$$\begin{array}{r} 31Q \\ + 1Q3 \\ \hline 501 \end{array}$$

- Find A and B in the addition.

$$\begin{array}{r} A \\ + A \\ + A \\ \hline BA \end{array}$$

- Find the digits A and B.

$$\begin{array}{r} BA \\ \times B3 \\ \hline 57A \end{array}$$

- Check the divisibility of 21436587 by 9.
- If the three digit number  $24x$  is divisible by 9, what is the value of  $x$ ?
- Check the divisibility of 2146587 by 3.
- Check the divisibility of 15287 by 3.
- If  $31z5$  is a multiple of 3, where  $z$  is a digit, what might be the values of  $z$ ?
- Check the divisibility of the following numbers by 9.  
1. 108    2. 616    3. 294    4. 432    5. 927
- If the division  $N \div 2$  leaves a remainder of 1, what might be the one's digit of  $N$ ?
- If the division  $N \div 5$  leaves a remainder of 3, what might be the ones digit of  $N$ ?
- If the division  $N \div 5$  leaves a remainder of 1, what might be the one's digit of  $N$ ?
- If the division  $N \div 5$  leaves a remainder of 4, what might be the one's digit of  $N$ ?
- If  $21y5$  is a multiple of 9, where  $y$  is a digit, what is the value of  $y$ ?
- If  $31z5$  is a multiple of 9, where  $z$  is a digit, what is the value of  $z$ ?
- If  $24x$  is a multiple of 3, where  $x$  is a digit, what is the value of  $x$ ?

19. Find the values of the letters in each of the following and give reasons for the steps involved.

$$\begin{array}{r} 1. \quad A \ B \\ + \ 3 \ 7 \\ \hline \quad 6 \ A \\ \hline \end{array}$$

$$\begin{array}{r} 2. \quad A \ B \\ \times \ 6 \\ \hline B \ B \ B \\ \hline \end{array}$$

$$\begin{array}{r} 3. \quad 1 \ 2 \ A \\ + \ 6 \ A \ B \\ \hline \quad A \ 0 \ 9 \\ \hline \end{array}$$

$$\begin{array}{r} 4. \quad A \ 1 \\ + \ 1 \ B \\ \hline \quad B \ 0 \\ \hline \end{array}$$

$$\begin{array}{r} 5. \quad 2 \ A \ B \\ + \ A \ B \ 1 \\ \hline \quad B \ 1 \ 8 \\ \hline \end{array}$$

$$\begin{array}{r} 6. \quad A \ B \\ \times \ 5 \\ \hline \quad C \ A \ B \\ \hline \end{array}$$

20. If  $41x$  is a multiple of 3, where  $x$  is a digit, what is the value of  $x$ ?

21. Using divisibility tests, determine which of the following numbers are divisible by 4; by 8:

- (a) 572 (b) 726352 (c) 5500 (d) 6000 (e) 12159  
(f) 14560 (g) 21084 (h) 31795072 (i) 1700 (j) 2150

22. Using divisibility tests, determine which of following numbers are divisible by 6:

- (a) 297144 (b) 1258 (c) 4335 (d) 61233 (e) 901352  
(f) 438750 (g) 1790184 (h) 12583 (i) 639210 (j) 17852

23. Using divisibility tests, determine which of the following numbers are divisible by 11:

- (a) 5445 (b) 10824 (c) 7138965 (d) 70169308 (e) 10000001  
(f) 901153

24. Write the smallest digit and the greatest digit in the blank space of each of the following numbers so that the number formed is divisible by 3 :

- (a)  $\_ \ 6724$  (b)  $4765 \ \_ \ 2$

25. Write a digit in the blank space of each of the following numbers so that the number formed is divisible by 11 :

- (a)  $92 \ \_ \ 389$  (b)  $8 \ \_ \ 9484$

.....

**HOT'S QUESTIONS**  
**CLASS VIII: CHAPTER - 16**  
**PLAYING WITH NUMBERS**

1. Given that the number 148101a095 is divisible by 11, where a is some digit, what are the possible values of a?
2. Given that the number 7713a8 is divisible by 4, where a is some digit, what are the possible values of a?
3. Given that the number 1735538a05 is divisible by 9, where a is some digit, what are the possible values of a?
4. Given that the number 60ab57377 is divisible by 99, where a and b are some digit, what are the possible values of a?
5. Without performing actual division, find the remainders left when 192837465 is divided by 9.
6. Without performing actual division, find the remainders left when 192837465 is divided by 11.
7. Without performing actual division, find the remainders left when 28735429 is divided by 11.
8. Without performing actual division, find the remainders left when 928174653 is divided by 11.
9. If the number 98215x2 is divisible by 4, where x is some digit, what are the possible values of x?
10. If the number 67x19 is divisible by 11, where x is some digit, what are the possible values of x?
11. Find the remainder when 981547 is divided by 5. Do this without doing actual division.
12. Find the remainder when 51439786 is divided by 3. Do this without doing actual division.
13. Solve the cryptarithm:  $2 \times \overline{ON} = \overline{GO}$ .
14. Solve the cryptarithm:  $3 \times \overline{ON} = \overline{GO}$ .
15. Solve the cryptarithm:  $4 \times \overline{ON} = \overline{GO}$ .
16. Solve the cryptarithm:  $AB \times 5 = CAB$ .
17. Show that the cryptarithm does not have any solution:  $AB \times 3 = CAB$
18. Show that the cryptarithm does not have any solution:  $AB \times 4 = CAB$
19. Solve the cryptarithm:  $AB \times AB = ACB$ .
20. Solve the cryptarithm:  $AB7 + 7AB = 98A$ .