

MATHEMATICS

QUESTION BANK

for

CLASS – VII

**CHAPTER WISE COVERAGE IN THE FORM
MCQ WORKSHEETS AND PRACTICE QUESTIONS**

Prepared by

M. S. KUMARSWAMY, TGT(MATHS)

M. Sc. Gold Medallist (Elect.), B. Ed.

Kendriya Vidyalaya GaCHIBOWLI

ISAMPAL
DEPUTY COMMISSIONER



केन्द्रीय विद्यालय संगठन, क्षेत्रीय कार्यालय,
के. कामराज मार्ग, बेंगलूर-560 042
KENDRIYA VIDYALAYA SANGATHAN
REGIONAL OFFICE
K. KAMARAJA ROAD, BANGALORE- 560042

F. DO-DC./2013-KVS(BGR)

Dated:05.09.2013

Dear Shri M.S.Kumarswamy,

It has been brought to my notice the good work done by you with regard to making question bank and worksheets for classes VI to X in Mathematics. I am pleased to look at your good work. Mathematics is one discipline which unfortunately and wrongly perceived as a phobia. May be lack of motivation from teachers and inadequate study habits of students is responsible for this state of affairs. Your work in this regard assumes a great significance. I hope your own students as well as students of other Vidyalayas will benefit by your venture. You may mail the material to all the Kendriya Vidyalayas of the region for their benefit. Keep up the good work.

May God bless!

Yours sincerely,

(Isampal)

Shri M.S.Kumarswamy
TGT (Maths)
Kendriya Vidyalaya
Donimalai

Copy to: the principals, Kendriya Vidyalayas, Bangalore Region with instructions to make use of the materials prepared by Mr. M.S.Kumarswamy being forwarded separately.

**DEDICATED
TO
MY FATHER**

LATE SHRI. M. S. MALLAYYA

MCQ WORKSHEET-I
CLASS – VII: CHAPTER – 1
INTEGERS

1. 2 subtracted from 7 gives
(a) -9 (b) 5 (c) -5 (d) 9
2. 5 added to -5 gives
(a) 10 (b) -10 (c) 0 (d) -25
3. 3 taken away from 0 gives
(a) 3 (b) -3 (c) 0 (d) not possible
4. Smallest integer is
(a) 0 (b) -1 (c) we cannot write (d) -10000
5. Which of the following statement is true:
(a) 2 subtracted from -3 gives 1 (b) -1 subtracted from -5 gives 6
(c) 3 subtracted from -8 gives -11 (d) 1 subtracted from -7 gives -6
6. Absolute value of -11 is
(a) 10 (b) -1 (c) 11 (d) -11
7. The number 3 less than -2 is
(a) -1 (b) 1 (c) 5 (d) -5
8. Which of the following numbers is to the right of -3 on number line ?
(a) -4 (b) -2 (c) -5 (d) -6
9. Which of the following number is not to the left of -10 on the number line ?
(a) -9 (b) -11 (c) -12 (d) -13
10. The number of integers between -2 and 2 is-
(a) 5 (b) 4 (c) 3 (d) 2
11. The opposite of -7 is
(a) -6 (b) 6 (c) 5 (d) 7
12. Sum of two negative integers is always
(a) Positive (b) Negative (c) 0 (d) 1
13. Sum of -30 and -12 is
(a) 42 (b) -18 (c) -42 (d) 18
14. In addition and subtraction of the integers the sign of answer depends upon
(a) Smaller Number (b) Their Difference (c) Their Sum (d) Greater numerical value
15. Sum of -14 and 9 is
(a) 23 (b) -23 (c) -5 (d) 5

MCQ WORKSHEET-II
CLASS – VII: CHAPTER – 1
INTEGERS

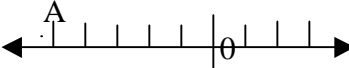
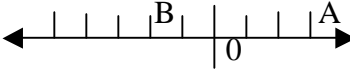
1. Which of the following number is greater than -1 ?
(a) -2 (b) -10 (c) 0 (d) -3
2. The preceding number of -1 on number line is:
(a) 0 (b) 1 (c) 2 (d) -2
3. Which number is 5 more than -3 ?
(a) -2 (b) 2 (c) 8 (d) -8
4. 7 steps to the left of 4 on number line gives:
(a) 3 (b) 11 (c) -11 (d) -3
5. 2 steps to the right of -1 on number line gives:
(a) 0 (b) 1 (c) -3 (d) 3
6. Which number is being represented by the point A on following number line:

(a) -9 (b) 5 (c) -5 (d) -6
7. What number is being represented by points A and B respectively on the number line:

(a) 3 and 2 (b) 2 and 3 (c) -3 and -2 (d) 3 and -2
8. The integer succeeding -9 is:
(a) -10 (b) 10 (c) -8 (d) 8
9. What will be the opposite of 3 Km south?
(a) 3 km east (b) 3 km north (c) 3 km north east (d) 3 km west
10. Which of the following set of numbers is in descending orders?
(a) $2, -2, 1, -1$ (b) $0, 1, 2, 3$ (c) $1, 0, -1, -2$ (d) $-3, -2, -1, 0$
11. Which of the following statements is false:
(a) 0 lies to the left of -1 (b) 2 lies to the right of 1
(c) 1 lies to the right of 0 (d) -2 lies to the left of -1
12. 5 added to the -1 gives
(a) 4 (b) -4 (c) 6 (d) -6
-

MCQ WORKSHEET-III
CLASS – VII: CHAPTER – 1
INTEGERS

1. 7 added to -1 gives
(a) 6 (b) -6 (c) -8 (d) 8
2. 3 added to -3 gives
(a) 0 (b) 6 (c) -6 (d) 9
3. 1 subtracted from -1 gives
(a) 0 (b) -1 (c) -2 (d) 2
4. Sum of -10 , -5 and 12 is
(a) 27 (b) -3 (c) 3 (d) -27
5. Which of the following statements is false
(a) $-4 > -5$ (b) $-4 < 5$ (c) $4 < -5$ (d) $4 > -5$
6. Which of the following is in increasing order
(a) 0, 1, -1 (b) -1 , -2 , -3 (c) -1 , 0, 1 (d) -1 , 1, -2
7. Which of the following is correct
(a) $-8 > -7$ (b) $1 < 0$ (c) $-1 < 0$ (d) $-2 > 4$
8. Which of the following number forms a pattern
(a) -6 , -3 , 0, 3 (b) -5 , -3 , -2 , 0 (c) 0, 2, 3, 4 (d) 1, 2, 4, 6
9. Sum of -36 and 29 is
(a) -65 (b) 65 (c) -7 (d) 7
10. Which of the following will give answer with negative sign
(a) $-48 + 79$ (b) $-40 + 40$ (c) $-48 + 30$ (d) $48 + (-39)$
11. What will be the additive inverse of -1 ?
(a) -2 (b) -1 (c) 0 (d) 1
12. Sum of two positive integers is always-
(a) Negative (b) positive (c) 0 (d) 1
13. Sum of a negative and a positive integer is –
(a) Always negative (b) either positive or negative (c) always positive (d) Zero
14. The pair of integers whose sum is -5
(a) 1, -4 (b) -1 , 6 (c) -3 , -2 (d) 5, 0
15. $39 - 50$ is
(a) Not possible (b) -89 (c) -11 (d) 10

MCQ WORKSHEET-IV
CLASS – VII: CHAPTER – 1
INTEGERS

- Q1. In addition and subtraction of two integers , sign of the answer depends upon
(a) Smaller number (b) Their difference (c) Their sum (d) Greater numerical value
- Q2. Sum of two negative number is always
(a) Positive (b) Negative (c) 0 (d) 1
- Q3. Sum of two Positive number is always
(a) Negative (b) Positive (c) 1 (d) 0
- Q4. Sum of -36 and 29 is
(a) -65 (b) 65 (c) -7 (d) 7
- Q5. Sum of -19 and -21 is
(a) -40 (b) 40 (c) 2 (d) -2
- Q6. Which of the following statement is false:
(a) $-7 + (-6) = -13$ (b) $-5 + 1 = 4$ (c) $2 + (-1) = 1$
(d) $8 + (-9) = -1$
- Q7. The pair of integers whose sum is -5
(a) $1, -4$ (b) $-1, 6$ (c) $-3, -2$ (d) $5, 0$
- Q8. What integers or number should be added to -5 to get 4
(a) 1 (b) -1 (c) -9 (d) 9
- Q9 . What will be the additive inverse of -5
(a) -6 (b) -4 (c) 3 (d) 5
- Q10. What will be the additive inverse of 7
(a) -7 (b) -6 (c) -5 (d) -4
- Q11. Predecessor of -9 is
(a) -8 (b) 8 (c) -10 (d) 10
- Q12. Successor of -1 is
(a) -2 (b) 0 (c) 1 (d) 2
- Q13. The value of $6 - (-3)$ is
(a) 3 (b) -9 (c) -3 (d) 9
- Q14. The value of $26 - 30$ is equal to
(a) 4 (b) -4 (c) -56 (d) 56
- Q15. Which of the following statement is true
(a) $7 - 4 = 4 - 7$ (b) $7 - 4 > 4 - 7$ (c) $7 - 4 < 4 - 7$ (d) $7 - 4 = -3$
-

MCQ WORKSHEET-V
CLASS – VII: CHAPTER – 1
INTEGERS

- Q1. Choose appropriate number for blank: $-7 - (\underline{\quad}) = 2$
(a) 5 (b) -5 (c) 9 (d) -9
- Q2. Multiplication of 3 and -4
(a) -7 (b) 12 (c) -12 (d) 7
- Q3. Multiplication of -2, -7 and -10 gives
(a) -34 (b) 19 (c) -140 (d) 90
- Q4. Multiplication of 2, -5 and 0 gives
(a) 10 (b) 0 (c) -10 (d) 7
- Q5. Identify the property used in the following: $2 \times 13 + 8 \times 13 = (2+8) \times 13$
(a) Commutative (b) Closure (c) Associative (d) Distributive
- Q6. Which number is multiplicative identity for the whole numbers
(a) 0 (b) 1 (c) 2 (d) 3
- Q7. What will be multiplicative inverse of -8
(a) 8 (b) $\frac{1}{8}$ (c) $-\frac{1}{8}$ (d) 0
- Q8. Which property is reflected in the following: $7 \times 5 = 5 \times 7$
(a) Closure (b) Commutative (c) Associative (d) Distributive
- Q9. $-18 \div 2$ gives
(a) 36 (b) 9 (c) -9 (d) -16
- Q10. $-6 \div (-3)$ gives
(a) -9 (b) 2 (c) -2 (d) 3
- Q11. 15 divided by -3 is equal to
(a) 12 (b) -12 (c) -5 (d) 5
- Q12. $0 \div 10$ gives
(a) 0 (b) 10 (c) 1 (d) -10
- Q13. Which of the following is not true
(a) $0 \div 2 = 0$ (b) $-25 \div 5 = -5$ (c) $12 \div 0 = 12$ (d) $4 \div 1 = 4$
- Q14. Which of the following is true
(a) $5 \div 7 = 7 \div 5$ (b) $0 \div 3 = 0 \div 5$ (c) $2 \div (3 - 1) = 2 \div 3 - 2 \div 1$
(d) $4 \div 1 = 1 \div 4$
- Q15. Which of the following does not represent pair of integer (a, b) such that $a \div b = 2$
(a) (-6, -3) (b) (-2, 1) (c) (-10, -5) (d) (8, 4)
-

MCQ WORKSHEET-VI
CLASS – VII: CHAPTER – 1
INTEGERS

- Q1 . On dividing a negative integers by other negative integer the quotient will be
(a) Always negative (b) Always positive (c) Either positive or negative (d) 1
- Q2. Which of the following statement is true
(a) $7 \div 0 = 7$ (b) $7 \div 0 = 0$ (c) $7 \div 0 = 0 \div 7$ (d) $0 \div 7 = 0$
- Q3. Product of two negative integers is always
(a) Always negative (b) Always positive (c) Either positive or negative (d) 0
- Q4. The integer whose product with -1 is -40 is
(a) 20 (b) -20 (c) -40 (d) 40
- Q5. Absolute value of -11 is
(a) -10 (b) 10 (c) 11 (d) 0
- Q6. $-8 \times 10 \times 9$ is equal to
(a) 27 (b) -27 (c) -720 (d) 720
- Q7. $16 \times 10 + 2$ is equal to
(a) 162 (b) 192 (c) 52 (d) 320
- Q8. $-16 \times (-1)$ is equal to
(a) -17 (b) 17 (c) 16 (d) -16
- Q9. $125 \div (-25)$ is equal to
(a) 1 (b) 5 (c) -5 (d) 100
- Q10. $(-50) \div \underline{\hspace{2cm}} = -1$, number in the blank will be
(a) 49 (b) 50 (c) -50 (d) 51
-

PRACTICE QUESTIONS
CLASS – VII: CHAPTER – 1
INTEGERS

1. Write the opposite of each of the following:
(i) Increase in class strength (ii) going north (iii) A loss of Rs 1000
2. Indicate the following by integers:
(i) 25° above zero (ii) 5° below zero (iii) 300m above the sea level
(iv) 250m below the sea level (v) A profit of Rs. 2000
3. Represent the following integers on number line:
(i) -4 (ii) 7 (iii) -8
4. Write all the integers between:
(i) -7 and 3 (ii) -2 and 2 (iii) -4 and 0
5. How many integers are between:
(i) -4 and 3 (ii) 5 and 12 (iii) -9 and -2
6. Represent the following using integers with proper sign: (a) 3 km above sea level (b) A loss of Rs 500
7. Find the sum of the pairs of integers: (a) -6, -4 (b) +3, -4 (c) +4, -2
8. Find the sum of -2 and -3, using the number line.
9. Subtract : (i) 3 from -4 (ii) -3 from -4
10. Using the number line, subtract : (a) 2 from -3 (b) -2 from -3.
11. How many integers are there between -9 and -2 ?
12. Calculate: $1 - 2 + 3 - 4 + 5 - 6 + 7 - 8 + 9 - 10$
13. The sum of two integers is 47. If one of the integers is -24, find the other.
14. Write the digits 0, 1, 2, 3, 4, 5, 6, 7, 8 and 9 in this order and insert '+' or '-' between them to get the result (a) 5 (b) -3
15. Compute each of the following:
(a) $30 + (-25) + (-10)$ (b) $(-20) + (-5)$
(c) $70 + (-20) + (-30)$ (d) $-50 + (-60) + 50$
(e) $1 + (-2) + (-3) + (-4)$ (f) $0 + (-5) + (-2)$
(g) $0 - (-6) - (+6)$ (h) $0 - 2 - (-2)$
16. If we denote the height of a place above sea level by a positive integer and depth below the sea level by a negative integer, write the following using integers with the appropriate signs:
(a) 200 m above sea level (b) 100 m below sea level
(c) 10 m above sea level (d) sea level
17. Write the opposite of each of the following:

- (a) Decrease in size (b) Failure
- (c) Profit of Rs.10 (d) 1000 A.D.
- (e) Rise in water level (f) 60 km south
- (g) 10 m above the danger mark of river Ganga
- (h) 20 m below the danger mark of the river Brahmaputra
- (i) Winning by a margin of 2000 votes
- (j) Depositing Rs.100 in the Bank account
- (k) 20°C rise in temperature.

18. Temperature of a place at 12:00 noon was +5°C. Temperature increased by 3°C in first hour and decreased by 1°C in the second hour. What was the temperature at 2:00 pm?
19. Write the digits 0, 1, 2, 3, ..., 9 in this order and insert '+' or '-' between them to get the result 3.
20. Write the integer which is its own additive inverse.
21. Write six distinct integers whose sum is 7.
22. Write the integer which is 4 more than its additive inverse.
23. Write the integer which is 2 less than its additive inverse.
24. Write two integers whose sum is less than both the integers.
25. Write two distinct integers whose sum is equal to one of the integers.
26. Using number line, how do you compare (a) two negative integers? (b) two positive integers? (c) one positive and one negative integer?
27. Observe the following : $1 + 2 - 3 + 4 + 5 - 6 - 7 + 8 - 9 = -5$
28. Change one '-' sign as '+' sign to get the sum 9.
29. Arrange the following integers in the ascending order : -2, 1, 0, -3, +4, -5
30. Arrange the following integers in the descending order : -3, 0, -1, -4, -3, -6
31. Write two integers whose sum is 6 and difference is also 6.
32. Write five integers which are less than -100 but greater than -150.
33. Write four pairs of integers which are at the same distance from 2 on the number line.
34. The sum of two integers is 30. If one of the integers is -42, then find the other.
35. Sum of two integers is -80. If one of the integers is -90, then find the other.
36. At Srinagar temperature was - 5°C on Monday and then it dropped by 2°C on Tuesday. What was the temperature of Srinagar on Tuesday? On Wednesday, it rose by 4°C. What was the temperature on this day?
37. A plane is flying at the height of 5000 m above the sea level. At a particular point, it is exactly above a submarine floating 1200 m below the sea level. What is the vertical distance between them?

38. Mohan deposits Rs 2,000 in his bank account and withdraws Rs 1,642 from it, the next day. If withdrawal of amount from the account is represented by a negative integer, then how will you represent the amount deposited? Find the balance in Mohan's account after the withdrawal.
39. Rita goes 20 km towards east from a point A to the point B. From B, she moves 30 km towards west along the same road. If the distance towards east is represented by a positive integer then, how will you represent the distance travelled towards west? By which integer will you represent her final position from A?
40. Write a pair of integers whose sum gives
(a) a negative integer (b) zero
(c) an integer smaller than both the integers.
(d) an integer smaller than only one of the integers.
(e) an integer greater than both the integers.
41. Write a pair of integers whose difference gives
(a) a negative integer. (b) zero.
(c) an integer smaller than both the integers.
(d) an integer greater than only one of the integers.
(e) an integer greater than both the integers.
42. Write down a pair of integers whose
(a) sum is -3 (b) difference is -5
(c) difference is 2 (d) sum is 0
43. Write down a pair of integers whose:
(a) sum is -7 (b) difference is -10 (c) sum is 0
44. Write a pair of negative integers whose difference gives 8.
45. Write a negative integer and a positive integer whose sum is -5 .
46. Write a negative integer and a positive integer whose difference is -3 .
47. Find: $4 \times (-8)$, $8 \times (-2)$, $3 \times (-7)$, $10 \times (-1)$ using number line.
48. Verify $(-30) \times [13 + (-3)] = [(-30) \times 13] + [(-30) \times (-3)]$
49. In a class test containing 15 questions, 4 marks are given for every correct answer and (-2) marks are given for every incorrect answer. (i) Gurpreet attempts all questions but only 9 of her answers are correct. What is her total score? (ii) One of her friends gets only 5 answers correct. What will be her score?
50. An elevator descends into a mine shaft at the rate of 5 metre per minute. What will be its position after one hour? If it begins to descend from 15 m above the ground, what will be its position after 45minutes?
51. A certain freezing process requires that room temperature be lowered from 40°C at the rate of 5°C every hour. What will be the room temperature 10 hours after the process begins?
52. In a test $(+5)$ marks are given for every correct answer and (-2) marks are given for every incorrect answer. (i) Radhika answered all the questions and scored 30 marks though she got 10

correct answers. (ii) Jay also answered all the questions and scored (-12) marks though he got 4 correct answers. How many incorrect answers had they attempted?

- 53.** A shopkeeper earns a profit of Re 1 by selling one pen and incurs a loss of 40 paise per pencil while selling pencils of her old stock. (i) In a particular month she incurs a loss of Rs 5. In this period, she sold 45 pens. How many pencils did she sell in this period? (ii) In the next month she earns neither profit nor loss. If she sold 70 pens, how many pencils did she sell?
- 54.** The temperature at 12 noon was 10°C above zero. If it decreases at the rate of 2°C per hour until midnight, at what time would the temperature be 8°C below zero? What would be the temperature at mid-night?
- 55.** An elevator descends into a mine shaft at the rate of 6 m/min. If the descent starts from 10 m above the ground level, how long will it take to reach - 350 m.
- 56.** Evaluate each of the following:
(a) $(-30) \div 10$ (b) $50 \div (-5)$ (c) $(-36) \div (-9)$
(d) $(-49) \div (49)$ (e) $13 \div [(-2) + 1]$ (f) $0 \div (-12)$
(g) $(-31) \div [(-30) + (-1)]$
(h) $[(-36) \div 12] \div 3$ (i) $[(-6) + 5] \div [(-2) + 1]$
- 57.** Find the product, using suitable properties:
(a) $26 \times (-48) + (-48) \times (-36)$ (b) $8 \times 53 \times (-125)$
(c) $15 \times (-25) \times (-4) \times (-10)$ (d) $(-41) \times 102$
(e) $625 \times (-35) + (-625) \times 65$ (f) $7 \times (50 - 2)$
(g) $(-17) \times (-29)$ (h) $(-57) \times (-19) + 57$
- 58.** Verify the following:
(a) $18 \times [7 + (-3)] = [18 \times 7] + [18 \times (-3)]$
(b) $(-21) \times [(-4) + (-6)] = [(-21) \times (-4)] + [(-21) \times (-6)]$
- 59.** A cement company earns a profit of Rs 8 per bag of white cement sold and a loss of Rs 5 per bag of grey cement sold.
(a) The company sells 3,000 bags of white cement and 5,000 bags of grey cement in a month. What is its profit or loss?
(b) What is the number of white cement bags it must sell to have neither profit nor loss, if the number of grey bags sold is 6,400 bags.
- 60.** Find each of the following products:
(i) $(-18) \times (-10) \times 9$ (ii) $(-20) \times (-2) \times (-5) \times 7$ (iii) $(-1) \times (-5) \times (-4) \times (-6)$
-

MCQ WORKSHEET-I
CLASS – VII: CHAPTER – 2
FRACTIONS AND DECIMALS

1. Which of the following fraction has numerator 5

- a) $\frac{2}{5}$ b) $\frac{5}{7}$ (c) $1\frac{5}{7}$ (d) $7\frac{1}{5}$

2. Which of the following fraction has denominator 8.

- a) $\frac{8}{3}$ b) $1\frac{3}{8}$ (c) $1\frac{8}{3}$ (d) $\frac{3}{8}$

3. What fraction does the shaded portion in the adjoining fig. represents.



- a) $\frac{5}{2}$ b) $\frac{3}{5}$ (c) $\frac{2}{5}$ (d) $\frac{5}{3}$

4. Which one of the following is proper fraction?

- a) $\frac{7}{5}$ b) $\frac{3}{2}$ (c) $\frac{4}{7}$ (d) $\frac{4}{3}$

5. Which one of the following is improper fraction?

- a) $\frac{2}{3}$ b) $\frac{5}{7}$ (c) $\frac{7}{4}$ (d) $\frac{1}{2}$

6. What is the value of $\frac{2}{7} + \frac{3}{7}$

- a) $\frac{5}{14}$ b) $\frac{5}{7}$ (c) $\frac{6}{7}$ (d) $\frac{35}{14}$

7. What is the value of $\frac{3}{5} + \frac{2}{7}$

- a) $\frac{5}{12}$ b) $\frac{29}{35}$ (c) $\frac{31}{35}$ (d) $\frac{5}{35}$

8. What is the value of $\frac{2}{3} + \frac{1}{3} + \frac{7}{3}$

- a) $\frac{10}{3}$ b) $\frac{10}{9}$ (c) $\frac{30}{3}$ (d) $\frac{10}{27}$

9. What is the value of $\frac{2}{3} + \frac{1}{3} + \frac{7}{3}$

- a) $\frac{10}{3}$ b) $\frac{10}{9}$ (c) $\frac{30}{3}$ (d) $\frac{10}{27}$

10. What is the value of $\frac{5}{8} - \frac{3}{8}$

- a) $\frac{37}{16}$ b) $\frac{1}{8}$ (c) $\frac{2}{8}$ (d) $\frac{43}{8}$

MCQ WORKSHEET-II
CLASS – VII: CHAPTER – 2
FRACTIONS AND DECIMALS

1. What is the value of $\frac{4}{5} - \frac{2}{3}$
- a) $\frac{2}{2}$ b) $\frac{14}{15}$ (c) $\frac{2}{15}$ (d) none of these

2. Which of the following drawing shows $2 \times \frac{1}{5}$

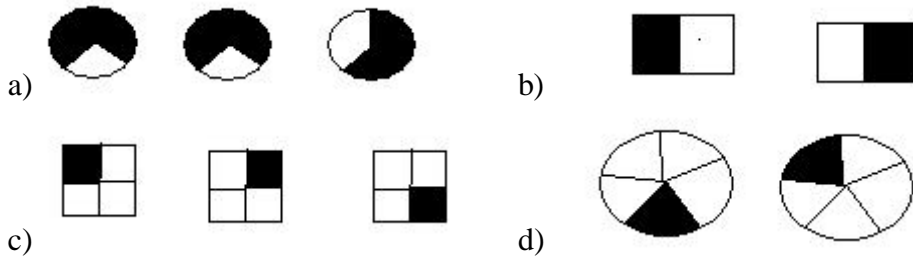

3. Which of the following drawing shows $3 \times \frac{3}{4} = 2\frac{1}{4}$

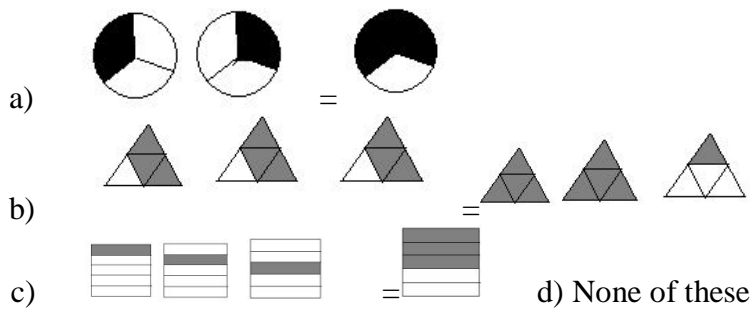

4. The value of $\frac{1}{2}$ of 24 is

- a) 12 b) $\frac{1}{12}$ (c) 48 (d) $\frac{1}{48}$

5. The product of $\frac{3}{4}$ and $\frac{1}{5}$ gives

- (a) $\frac{3}{20}$ (b) $\frac{5}{12}$ (c) $\frac{12}{5}$ (d) $\frac{20}{3}$

6. Which of the following product gives the value $\frac{78}{5}$

- (a) $3 \times 5\frac{1}{5}$ (b) $\frac{1}{3}$ (c) $3 \times \frac{5}{26}$ (d) None of these

7. The product of $\frac{2}{5} \times 5\frac{1}{4}$ gives

- (a) $\frac{1}{2}$ (b) $\frac{21}{10}$ (c) $\frac{11}{10}$ (d) $\frac{15}{10}$

8. The reciprocal of $1\frac{2}{3}$ is

- (a) $\frac{3}{2}$ (b) $1\frac{3}{2}$ (c) $\frac{5}{3}$ (d) $\frac{3}{5}$

9. The value of $\frac{3}{4}$ of 12 is
(a) 16 (b) 1 (c) 9 (d) $\frac{1}{16}$
10. The value of $3\frac{1}{2}$ of $\frac{8}{3}$ is
(a) 4 (b) $\frac{28}{3}$ (c) $\frac{9}{4}$ (d) $\frac{21}{16}$
11. The value of $4\frac{1}{3}$ of 3 is
(a) 4 (b) 13 (c) $\frac{13}{9}$ (d) $\frac{9}{13}$
12. Which of the following is the least form of $\frac{18}{36}$
(a) $\frac{3}{6}$ (b) $\frac{9}{18}$ (c) $\frac{1}{2}$ (d) $\frac{2}{1}$
13. What is the sum of 5.300 and 3.250
(a) 8.550 (b) 85.50 (c) 5.6250 (d) 8550
14. What is the value of $29.35 - 04.56$
(a) 23.75 (b) 16.35 (c) 16.25 (d) 24.79
15. Which one of the following is greater
(a) 5.0 (b) 0.5 (c) 0.005 (d) 0.05
-

MCQ WORKSHEET-III
CLASS – VII: CHAPTER – 2
FRACTIONS AND DECIMALS

1. Which one of the following is smaller
(a) 2.031 (b) 2.301 (c) 0.2301 (d) 23.01
2. 7 Rupees 7 paise can be written in rupees as
(a) Rs7.07 (b) Rs7.70 (c) Rs0.707 (d) Rs 770
3. 5 cm in Km can be written as
(a) 0.0005 (b) 0.00005 (c) 0.0005 (d) 0.05
4. The place value of 2 in 21.38 is
(a) Ones (b) Tens (c) Tenth (d) Hundredth
5. Which one of the following represent the expansion
$$2 \times 10 + 0 \times 1 + 0 \times \frac{1}{10} + 3 \times \frac{1}{100}$$

(a) 20.03 (b) 2.03 (c) 200.03 (d) 2.034
6. The value of 2.71×5 is
(a) 135.5 (b) 1355 (c) 13.55 (d) 1.355
7. The product of 153.7 and 10 is
(a) 1.537 (b) 15.37 (c) 153.7 (d) 1537
8. The value of 43.07×100 is
(a) 4.307 (b) 4307 (c) 43.07 (d) 430.7
9. The value of 0.03×1000 is
(a) 0.00003 (b) 3 (c) 0.003 (d) 30
10. The value of 1.3×3.1 is
(a) 403 (b) 0.403 (c) 4.03 (d) 0.0403
11. The value of $0.80 \div 5$ is
(a) 16 (b) 0.16 (c) $\frac{1}{16}$ (d) 1.6
12. The value of $52.5 \div 10$ is
(a) 5.25 (b) 0.525 (c) 525 (d) 5250
13. The value of $0.78 \div 100$ is
(a) 7800 (b) 0.0078 (c) 0.78 (d) 7.8
14. The value of $26.3 \div 1000$ is
(a) 0.0263 (b) 0.2630 (c) 26300 (d) 26.300
15. The value of $7.75 \div 0.25$ is
(a) 31 (b) 0.0031 (c) 0.31 (d) 3.1

PRACTICE QUESTIONS
CLASS – VII: CHAPTER – 2
FRACTIONS AND DECIMALS

1. Fill in the blanks:

(a) $\frac{11}{16} \cdots \frac{14}{15}$ (b) $\frac{8}{15} \cdots \frac{95}{14}$ (c) $\frac{12}{75} \cdots \frac{32}{200}$

2. Ali divided one fruit cake equally among six persons. What part of the cake he gave to each person?

3. Express $\frac{11}{20}$ as a decimal.

4. Express $6\frac{2}{3}$ as an improper fraction.

5. Express $3\frac{2}{5}$ as a decimal.

6. Express 0.041 as a fraction.

7. Express 6.03 as a mixed fraction.

8. Arrange the fractions $\frac{2}{3}, \frac{3}{4}, \frac{1}{2}$ and $\frac{5}{6}$ in ascending order

9. Arrange the fractions $\frac{6}{7}, \frac{7}{8}, \frac{4}{5}$ and $\frac{3}{4}$ in descending order.

10. Write $\frac{3}{4}$ as a fraction with denominator 44

11. Write $\frac{5}{6}$ as a fraction with numerator 60

12. Write $\frac{129}{8}$ as a mixed fraction.

13. Add the fractions $\frac{3}{8}$ and $\frac{2}{3}$.

14. Add the fractions $\frac{3}{8}$ and $6\frac{3}{4}$.

15. Subtract $\frac{1}{6}$ from $\frac{1}{2}$.
16. Subtract $8\frac{1}{3}$ from $\frac{100}{9}$.
17. Subtract $1\frac{1}{4}$ from $6\frac{1}{2}$.
18. Add $1\frac{1}{4}$ and $6\frac{1}{2}$.
19. Katrina rode her bicycle $6\frac{1}{2}$ km in the morning and $8\frac{3}{4}$ km in the evening. Find the distance travelled by her altogether on that day.
20. A rectangle is divided into certain number of equal parts. If 16 of the parts so formed represent the fraction $\frac{1}{4}$, find the number of parts in which the rectangle has been divided.
21. Grip size of a tennis racquet is $11\frac{9}{80}$ cm. Express the size as an improper fraction.
22. Mr. Rajan got a job at the age of 24 years and he got retired from the job at the age of 60 years. What fraction of his age till retirement was he in the job?
23. On an average $\frac{1}{10}$ of the food eaten is turned into organism's own body and is available for the next level of consumer in a food chain. What fraction of the food eaten is not available for the next level?
24. The food we eat remains in the stomach for a maximum of 4 hours. For what fraction of a day, does it remain there?
25. It was estimated that because of people switching to Metro trains, about 33000 tonnes of CNG, 3300 tonnes of diesel and 21000 tonnes of petrol was saved by the end of year 2007. Find the fraction of : (i) the quantity of diesel saved to the quantity of petrol saved. (ii) the quantity of diesel saved to the quantity of CNG saved.
26. A cup is $\frac{1}{3}$ full of milk. What part of the cup is still to be filled by milk to make it full?
27. Mary bought $3\frac{1}{2}$ m of lace. She used $1\frac{3}{4}$ m of lace for her new dress. How much lace is left with her?
28. Sunil purchased $12\frac{1}{2}$ litres of juice on Monday and $14\frac{3}{4}$ litres of juice on Tuesday. How many litres of juice did he purchase together in two days?

29. When Sunita weighed herself on Monday, she found that she had gained $1\frac{1}{4}$ kg. Earlier her weight was $46\frac{3}{8}$ kg. What was her weight on Monday?
30. Nazima gave $2\frac{3}{4}$ litres out of the $5\frac{1}{2}$ litres of juice she purchased to her friends. How many litres of juice is left with her?
31. Roma gave a wooden board of length $150\frac{1}{4}$ cm to a carpenter for making a shelf. The Carpenter sawed off a piece of $40\frac{1}{5}$ cm from it. What is the length of the remaining piece?
32. Nasir travelled $3\frac{1}{2}$ km in a bus and then walked $1\frac{1}{8}$ km to reach a town. How much did he travel to reach the town?
33. The fish caught by Neetu was of weight $3\frac{3}{4}$ kg and the fish caught by Narendra was of weight $2\frac{1}{2}$ kg. How much more did Neetu's fish weigh than that of Narendra?
34. Neelam's father needs $1\frac{3}{4}$ m of cloth for the skirt of Neelam's new dress and $\frac{1}{2}$ m for the scarf. How much cloth must he buy in all?
35. Write a pair of fractions whose sum is $\frac{7}{11}$ and the difference is $\frac{2}{11}$
36. Simplify: $\frac{5}{6} + \frac{3}{4} + \frac{1}{2}$
37. Simplify: $\frac{5}{8} + \frac{2}{5} + \frac{3}{4}$
38. Simplify: $\frac{3}{10} + \frac{7}{15} + \frac{3}{5}$
39. Simplify: $4\frac{2}{3} + 3\frac{1}{4} + 7\frac{1}{2}$
40. Simplify: $7\frac{1}{3} + 3\frac{2}{3} + 5\frac{1}{6}$

41. Simplify: $2\frac{1}{3} + 1\frac{2}{3} + 5\frac{1}{6}$

42. Simplify: $2\frac{1}{3} - 1\frac{2}{3} + 5\frac{1}{6}$

43. Simplify: $7\frac{1}{3} + 3\frac{2}{3} - 5\frac{1}{6}$

44. If $\frac{5}{8} = \frac{20}{p}$, then find the value of p.

45. Arrange in descending order: $\frac{8}{17}, \frac{8}{5}, \frac{8}{9}, \frac{8}{13}$

46. Arrange in descending order: $\frac{5}{9}, \frac{3}{12}, \frac{1}{3}, \frac{4}{15}$

47. Arrange in descending order: $\frac{2}{7}, \frac{11}{35}, \frac{9}{14}, \frac{13}{28}$

48. Arrange in ascending order: $\frac{2}{5}, \frac{3}{4}, \frac{1}{2}, \frac{3}{5}$

49. Arrange in ascending order: $\frac{4}{6}, \frac{3}{8}, \frac{6}{12}, \frac{5}{16}$

50. Arrange in ascending order: $\frac{5}{6}, \frac{3}{8}, \frac{6}{12}, \frac{1}{3}, \frac{6}{8}$

51. Ramesh solved $\frac{2}{7}$ part of an exercise while Seema solved $\frac{4}{5}$ of it. Who solved lesser part?

52. Sameera purchased $3\frac{1}{2}$ kg apples and $4\frac{3}{4}$ kg oranges. What is the total weight of fruits purchased by her?

53. Suman studies for $5\frac{2}{3}$ hours daily. She devotes $2\frac{4}{5}$ hours of her time for Science and Mathematics. How much time does she devote for other subjects?

54. Arrange the following in descending order:

55. A rectangular sheet of paper is $12\frac{1}{2}$ cm long and $10\frac{2}{3}$ cm wide. Find its perimeter.

56. Find the perimeters of (i) . ABE (ii) the rectangle BCDE in this figure. Whose perimeter is greater?

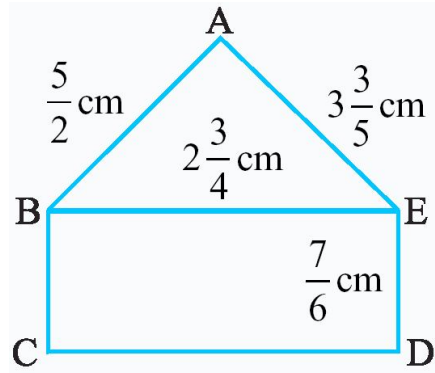

57. Ritu ate $\frac{4}{5}$ part of an apple and the remaining apple was eaten by her brother Somu. How much part of the apple did Somu eat? Who had the larger share? By how much?
58. Michael finished colouring a picture in $\frac{7}{12}$ hour. Vaibhav finished colouring the same picture in $\frac{3}{4}$ hour. Who worked longer? By what fraction was it longer?
59. Represent pictorially: $2 \times \frac{2}{5} = \frac{4}{5}$
60. In a class of 40 students $\frac{1}{5}$ of the total number of students like to study English, $\frac{2}{5}$ of the total number like to study mathematics and the remaining students like to study Science.
 (i) How many students like to study English?
 (ii) How many students like to study Mathematics?
 (iii) What fraction of the total number of students like to study Science?
61. Find $\frac{1}{2}$ of (i) 24 (ii) 46
62. Find $\frac{3}{4}$ of (i) 16 (ii) 36
63. Multiply and express as a mixed fraction:
 (a) $3 \times 5\frac{1}{5}$ (b) $5 \times 6\frac{3}{4}$ (c) $3\frac{1}{4} \times 6$ (d) $3\frac{2}{5} \times 8$
64. Find $\frac{1}{2}$ of (i) $2\frac{3}{4}$ (ii) $4\frac{2}{9}$
65. Find $\frac{5}{8}$ of (i) $3\frac{5}{6}$ (ii) $9\frac{2}{3}$
66. Sushant reads $\frac{1}{3}$ part of a book in 1 hour. How much part of the book will he read in $2\frac{1}{5}$ hours?
67. Vidya and Pratap went for a picnic. Their mother gave them a water bag that contained 5 litres of water. Vidya consumed $\frac{2}{5}$ of the water. Pratap consumed the remaining water.
 (i) How much water did Vidya drink?
 (ii) What fraction of the total quantity of water did Pratap drink?
68. Saili plants 4 saplings, in a row, in her garden. The distance between two adjacent saplings is $\frac{3}{4}$ m. Find the distance between the first and the last sapling.

69. Lipika reads a book for $1\frac{3}{4}$ hours every day. She reads the entire book in 6 days. How many hours in all were required by her to read the book?
70. A car runs 16 km using 1 litre of petrol. How much distance will it cover using $2\frac{3}{4}$ litres of petrol.
71. Find: (i) $\frac{2}{5} \div \frac{1}{2}$ (ii) $2\frac{1}{3} \div \frac{3}{5}$ (iii) $3\frac{1}{5} \div 1\frac{2}{3}$ (iv) $2\frac{1}{5} \div 1\frac{1}{5}$
72. Express in kg:
(i) 200 g (ii) 3470 g (iii) 4 kg 8 g (iv) 2598 mg
73. Write the following decimal numbers in the expanded form:
(i) 20.03 (ii) 2.03 (iii) 200.03 (iv) 2.034
74. Write the place value of 2 in the following decimal numbers:
(i) 2.56 (ii) 21.37 (iii) 10.25 (iv) 9.42 (v) 63.352.
75. Express as rupees using decimals.
(a) 5 paise (b) 350 paise (c) 2 rupees 60 paise (d) 5 rupees 9 paise
76. Express as metres using decimals.
(a) 15 cm (b) 8 cm (c) 2 m 15 cm (d) 3 m 70 cm
77. Express as cm using decimals.
(a) 25 mm (b) 5 mm (c) 176 mm (d) 4 cm 5 mm
78. Express as km using decimals.
(a) 6 m (b) 55 m (c) 4545 m (d) 6 km 50 m
79. Express as kg using decimals.
(a) 8 g (b) 160g (c) 7550 g (d) 6 kg 80 g (e) 5 kg 20 g
80. Express each of the following without using decimals:
(a) Rs.5.25 (b) 8.354 g (c) 3.5cm (d) 3.05km
(e) 7.54m (f) 15.005 kg (g) 12.05m (h) 0.2m
81. Shyama bought 5 kg 300 g apples and 3 kg 250 g mangoes. Sarala bought 4 kg 800 g oranges and 4 kg 150 g bananas. Who bought more fruits?
82. How much less is 28 km than 42.6 km?
83. The side of an equilateral triangle is 3.5 cm. Find its perimeter.
84. The length of a rectangle is 7.1 cm and its breadth is 2.5 cm. What is the area of the rectangle?
85. A two-wheeler covers a distance of 55.3 km in one litre of petrol. How much distance will it cover in 10 litres of petrol?
86. Find the area of rectangle whose length is 5.7cm and breadth is 3 cm.
87. Find the average of 4.2, 3.8 and 7.6.

88. Each side of a regular polygon is 2.5 cm in length. The perimeter of the polygon is 12.5cm. How many sides does the polygon have?
89. A car covers a distance of 89.1 km in 2.2 hours. What is the average distance covered by it in 1 hour?
90. Convert 2009 paise to rupees and express the result as a mixed fraction.
91. Convert 1537cm to m and express the result as an improper fraction.
92. Convert 2435m to km and express the result as mixed fraction.
93. Express 0.041 as a fraction.
94. A vehicle covers a distance of 43.2 km in 2.4 litres of petrol. How much distance will it cover in one litre of petrol?
95. Find:
(i) $7 \div 3.5$ (ii) $36 \div 0.2$ (iii) $3.25 \div 0.5$ (iv) $30.94 \div 0.7$ (v) $0.5 \div 0.25$
(vi) $7.75 \div 0.25$ (vii) $76.5 \div 0.15$ (viii) $37.8 \div 1.4$ (ix) $2.73 \div 1.3$
96. Find:
(i) $7.9 \div 1000$ (ii) $26.3 \div 1000$ (iii) $38.53 \div 1000$
(iv) $128.9 \div 1000$ (v) $0.5 \div 1000$
97. Find:
(i) $0.4 \div 2$ (ii) $0.35 \div 5$ (iii) $2.48 \div 4$ (iv) $65.4 \div 6$
(v) $651.2 \div 4$ (vi) $14.49 \div 7$ (vii) $3.96 \div 4$ (viii) $0.80 \div 5$
98. Find: (i) $7.75 \div 0.25$ (ii) $42.8 \div 0.02$ (iii) $5.6 \div 1.4$
99. Find: (i) $15.5 \div 5$ (ii) $126.35 \div 7$
100. Find:
(i) 2.5×0.3 (ii) 0.1×51.7 (iii) 0.2×316.8 (iv) 1.3×3.1
(v) 0.5×0.05 (vi) 11.2×0.15 (vii) 1.07×0.02
(viii) 10.05×1.05 (ix) 101.01×0.01 (x) 100.01×1.1
-

MCQ WORKSHEET-I
CLASS – VII: CHAPTER – 3
DATA HANDLINGS

1. The mean of the first five whole number is _____ .
a. 2 b. 5 c. 3 d. 4
 2. The mean of the first five natural number is _____ .
a. 2 b. 5 c. 3 d. 4
 3. The mean of the first seven natural number is _____ .
a. 2 b. 5 c. 3 d. 4
 4. The median of the first ten natural number is _____ .
a. 2.5 b. 5.5 c. 3.5 d. 4.5
 5. The median of the first ten prime number is _____ .
a. 2.5 b. 5.5 c. 3.5 d. none of these
 6. A cricketer scores the following runs in eight innings :
58 , 76 , 40 , 35 , 46 , 45 , 0 , 100
What will be their mean score ?
a. 400 b. 50 c. 200 d. 100
 7. What will be the range of following data ?
32 , 41 , 28 , 54 , 35 , 26 , 33 , 23 , 38 , 40
a. 25 b. 23 c. 31 d. 54
 8. The tally mark ~~||||~~ shows frequency _____ .
a. 4 b. 5 c. 0 d. 3
 9. Which observation in the following data has maximum frequency ?
1 , 1 , 2 , 4 , 3 , 2 , 1 , 2 , 2 , 4
a. 4 b. 3 c. 1 d. 2
 10. The tally mark ~~||||~~ ~~||||~~ ~~||||~~ shows frequency _____ .
a. 15 b. 13 c. 12 d. none of these
 11. The mode of the data 2 , 2 , 2 , 3 , 3 , 4 , 5 , 5 , 5 , 6 , 6 , 8 is _____ .
a. 2 b. 5 c. 8 d. 2 & 5 both
 12. A data can have _____ mode .
a. Only one b. only two c. only 3 d. more than one
-

MCQ WORKSHEET-II
CLASS – VII: CHAPTER – 3
DATA HANDLINGS

1. Median of the data 13,16,12,14,19,12,14,13,14 is _____.
a. 14 b. 19 c. 12 d. 13
2. Mode and median of the data 13,16,12,14,19,12,14,13,14 are:
a. 13 & 14 b. 14 & 13 c. 14 & 14 d. 19 & 13

Read the following bar graph which shows the number of books sold by a bookstore during five consecutive years and answer the question given below (Q3-Q8)

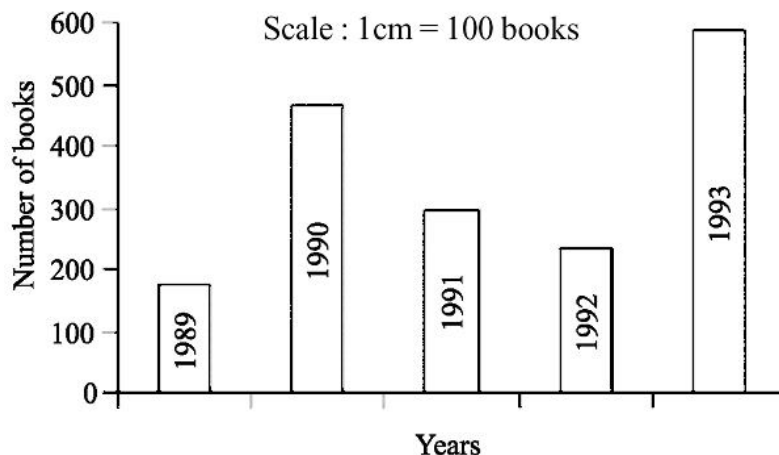

3. How many books were sold in 1989 ?
a. 100 b. 200 c. 300 d. 600
4. In which year were 400 books sold ?
a. 1990 b. 1991 c. 1993 d. 1989
5. In which year were fewer than 200 books sold ?
a. 1989 b. 1991 c. 1993 d. 1992
6. What will be the difference of number of books sold in 1993 and 1990 ?
a. 600 b. 200 c. 400 d. 100
7. How many books were sold from 1989 to 1991?
a. 600 b. 900 c. 400 d. 800
8. How many books were sold from 1991 to 1993?
a. 1300 b. 1000 c. 900 d. 800
9. There are 6 marbles in a box with number 1 to 6 marked on each of them . What is the probability of drawing a marble with number 2 ?
a. $\frac{1}{6}$ b. $\frac{1}{5}$ c. $\frac{1}{3}$ d. 1
10. A coin is flipped to decide which team starts the game . What is the probability of your team will start ?
a. $\frac{1}{4}$ b. $\frac{1}{2}$ c. 1 d. 0

PRACTICE QUESTIONS
CLASS – VII: CHAPTER – 3
DATA HANDLINGS

1. A batsman scored the following number of runs in six innings:
36, 35, 50, 46, 60, 55
Calculate the mean runs scored by him in an inning.
2. Ashish studies for 4 hours, 5 hours and 3 hours respectively on three consecutive days. How many hours does he study daily on an average?
3. Find the mean of first five natural numbers.
4. Find the mean of first six odd natural numbers.
5. Find the mean of first seven even natural numbers.
6. Find the mean of first five prime numbers.
7. Find the mean of first six multiples of 5.
8. Find the median of first 15 odd numbers.
9. Find the median of first 10 even numbers.
10. Find the median of first 50 whole numbers.
11. Find the median of 3, 11, 7, 2, 5, 9, 9, 2, 10.
12. Find the median of 9, 25, 18, 15, 6, 16, 8, 22, 21.
13. The ages in years of 10 teachers of a school are:
32, 41, 28, 54, 35, 26, 23, 33, 38, 40
 - (i) What is the age of the oldest teacher and that of the youngest teacher?
 - (ii) What is the range of the ages of the teachers?
 - (iii) What is the mean age of these teachers?
14. A cricketer scores the following runs in eight innings: 58, 76, 40, 35, 46, 45, 0, 100.
Find the mean score.
15. The marks (out of 100) obtained by a group of students in a science test are
85, 76, 90, 85, 39, 48, 56, 95, 81 and 75.
Find the: (i) Highest and the lowest marks obtained by the students.
(ii) Range of the marks obtained.
(iii) Mean marks obtained by the group.
16. The enrolment in a school during six consecutive years was as follows:
1555, 1670, 1750, 2013, 2540, 2820
Find the mean enrolment of the school for this period.
17. The heights of 10 girls were measured in cm and the results are as follows:
135, 150, 139, 128, 151, 132, 146, 149, 143, 141.
 - (i) What is the height of the tallest girl? (ii) What is the height of the shortest girl?
 - (iii) What is the range of the data? (iv) What is the mean height of the girls?
 - (v) How many girls have heights more than the mean height.
18. Following are the margins of victory in the football matches of a league.
1, 3, 2, 5, 1, 4, 6, 2, 5, 2, 2, 2, 4, 1, 2, 3, 1, 1, 2, 3, 2,
6, 4, 3, 2, 1, 1, 4, 2, 1, 5, 3, 3, 2, 3, 2, 4, 2, 1, 2
Find the mode of this data.

19. Find the mode of 2, 6, 5, 3, 0, 3, 4, 3, 2, 4, 5, 2, 4
20. Find the mode of the numbers: 2, 2, 2, 3, 3, 4, 5, 5, 5, 6, 6, 8
21. Find the mode of the following data:
12, 14, 12, 16, 15, 13, 14, 18, 19, 12, 14, 15, 16, 15, 16, 16, 15,
17, 13, 16, 16, 15, 15, 13, 15, 17, 15, 14, 15, 13, 15, 14
22. Heights (in cm) of 25 children are given below:
168, 165, 163, 160, 163, 161, 162, 164, 163, 162, 164, 163, 160, 163, 16, 165,
163, 162, 163, 164, 163, 160, 165, 163, 162
What is the mode of their heights? What do we understand by Mode here?
23. Find the median of the data: 24, 36, 46, 17, 18, 25, 35
24. The scores in mathematics test (out of 25) of 15 students is as follows:
19, 25, 23, 20, 9, 20, 15, 10, 5, 16, 25, 20, 24, 12, 20
Find the mode and median of this data. Are they same?
25. The runs scored in a cricket match by 11 players is as follows:
6, 15, 120, 50, 100, 80, 10, 15, 8, 10, 15
Find the mean, mode and median of this data. Are the three same?
26. The weights (in kg.) of 15 students of a class are:
38, 42, 35, 37, 45, 50, 32, 43, 43, 40, 36, 38, 43, 38, 47
(i) Find the mode and median of this data.
(ii) Is there more than one mode?
27. Find the mode and median of the data: 13, 16, 12, 14, 19, 12, 14, 13, 14
28. Two hundred students of 6th and 7th class were asked to name their favourite colour so as to decide upon what should be the colour of their School Building. The results are shown in the following table. Represent the given data on a bar graph.

Favourite Colour	Red	Green	White	Yellow	Blue
<u>Number of Students</u>	43	19	55	49	34

Answer the following questions with the help of the bar graph:

- (i) Which is the most preferred colour and which is the least preferred?
(ii) How many colours are there in all? What are they?
29. Following data gives total marks (out of 600) obtained by six children of a particular class. Represent the data on a bar graph.

<u>Students</u>	Ajay	Bali	Dipti	Geetika	Hari	Faiyaz
Marks Obtained	450	500	300	360	400	540

30. A mathematics teacher wants to see, whether the new technique of teaching she applied after quarterly test was effective or not. She takes the scores of the 5 weakest children in the quarterly test (out of 25) and in the half yearly test (out of 25):

Students	Ashish	Kavish	Mohan	Arun	Uday
Quarterly	10	15	12	9	20
Half Yearly	15	18	16	15	21

31. There are 6 marbles in a box with numbers from 1 to 6 marked on each of them.
(i) What is the probability of drawing a marble with number 2?
(ii) What is the probability of drawing a marble with number 5?
32. When a die is thrown, list the outcomes of an event of getting (i) (a) a prime number (b) not a prime number. (ii) (a) a number greater than 5 (b) a number not greater than 5.

MCQ WORKSHEET-I
CLASS – VII: CHAPTER – 4
SIMPLE EQUATIONS

1. Write the statements “The sum of three times x and 11 is 32” in the form of equations:
· (a) $6x - 5$ (b) $3x + 11$ (c) $11x + 3$ (d) $3x$
 2. Write the statements “If you subtract 5 from 6 times a number, you get 7.” in the form of equations:
· (a) $6x - 5 = 7$ (b) $5x - 6 = 7$ (c) $x - 5 = 7$ (d) $x - 6 = 7$
 3. Write the statements “One fourth of m is 3 more than 7” in the form of equations:
· (a) $4m - 7 = 3$ (b) $m - 4 = 3$ (c) $\frac{1}{4}m - 7 = 3$ (d) $\frac{1}{4}m - 3 = 7$
 4. Write the statements “One third of a number plus 5 is 8” in the form of equations:
· (a) $3m + 5 = 8$ (b) $m + 5 = 8$ (c) $\frac{1}{3}m + 5 = 8$ (d) $\frac{1}{3}m + 8 = 5$
 5. Which is a solution of the equation $2x = 12$
· (a) $x = 2$ (b) $x = 3$ (c) $x = 4$ (d) $x = 6$
 6. Which is a solution of the equation $x + 4 = 6$
· (a) $x = 2$ (b) $x = 3$ (c) $x = 4$ (d) $x = 6$
 7. Which is a solution of the equation $7x + 5 = 19$
· (a) $x = 2$ (b) $x = 3$ (c) $x = 4$ (d) $x = 6$
 8. Which is a solution of the equation $4x - 3 = 13$
· (a) $x = 2$ (b) $x = 3$ (c) $x = 4$ (d) $x = 6$
 9. Which is a solution of the equation $5x + 2 = 17$
· (a) $x = 2$ (b) $x = 3$ (c) $x = 4$ (d) $x = 6$
 10. Which is a solution of the equation $3x - 14 = 4$.
(a) $x = 2$ (b) $x = 3$ (c) $x = 4$ (d) $x = 6$
 11. Write the statements “The sum of numbers x and 4 is 9” in the form of equations:
· (a) $x - 4 = 9$ (b) $x + 4 = 9$ (c) $x + 9 = 4$ (d) none of these
 12. Write the statements “2 subtracted from a number is 8” in the form of equations:
· (a) $x - 8 = 2$ (b) $x - 2 = 8$ (c) $x + 2 = 8$ (d) none of these
 13. Write the statements “Seven times a number plus 7 gets you 77” in the form of equations:
· (a) $7x - 7 = 77$ (b) $7x + 7 = 77$ (c) $x + 7 = 77$ (d) none of these
 14. Write the statements “If you take away 6 from 6 times a number, you get 60” in the form of equations:
· (a) $6x + 6 = 60$ (b) $6x - 6 = 60$ (c) $x - 6 = 60$ (d) none of these
 15. Write the statements “If you add 3 to one-third of a number, you get 30” in the form of equations:
· (a) $x + 3 = 30$ (b) $\frac{1}{3}x + 3 = 30$ (c) $x + \frac{1}{3} = 30$ (d) none of these
-

MCQ WORKSHEET-II
CLASS – VII: CHAPTER – 4
SIMPLE EQUATIONS

1. The solution of the equation $p + 4 = 15$ is $p =$
(a) 12 (b) 13 (c) 14 (d) 11
2. The solution of the equation $m - 7 = 3$ is $m =$
(a) 10 (b) 13 (c) 12 (d) 11
3. The solution of the equation $2m = 7$ is $m = .$
(a) 12 (b) 13 (c) 14 (d) none of these
4. The solution of the equation $\frac{m}{5} = 3$ is $m = .$
(a) 12 (b) 13 (c) 15 (d) none of these
5. The solution of the equation $\frac{3m}{5} = 6$ is $m = .$
(a) 12 (b) 11 (c) 10 (d) none of these
6. The solution of the equation $\frac{p}{2} + 2 = 8$ is $p =$
(a) 12 (b) 13 (c) 14 (d) 11
7. The solution of the equation $3p + 4 = 25$ is $p =$
(a) 5 (b) 6 (c) 4 (d) 7
8. The solution of the equation $4p - 2 = 18$ is $p =$
. (a) 5 (b) 6 (c) 4 (d) 7
9. The solution of the equation $3n + 7 = 25$ is $n = .$
(a) 12 (b) 11 (c) 10 (d) none of these
10. The solution of the equation $2p - 1 = 23$ is $p =$
(a) 12 (b) 11 (c) 10 (d) none of these
11. The solution of the equation $\frac{20p}{3} = 40$ is $p =$
. (a) 5 (b) 6 (c) 4 (d) 7
12. The solution of the equation $\frac{3p}{10} = 6$ is $p =$
. (a) 10 (b) 20 (c) 30 (d) none of these

MCQ WORKSHEET-III
CLASS – VII: CHAPTER – 4
SIMPLE EQUATIONS

1. The solution of the equation $3n - 2 = 46$ is $n =$.
(a) 12 (b) 11 (c) 16 (d) none of these
2. The solution of the equation $5m + 7 = 17$ is $m =$.
(a) 2 (b) 3 (c) 4 (d) none of these
3. The sum of three times a number and 11 is 32. Find the number.
(a) 6 (b) 7 (c) 8 (d) none of these
4. Find a number, such that one fourth of the number is 3 more than 7.
(a) 40 (b) 20 (c) 30 (d) none of these
5. Raju's father's age is 5 years more than three times Raju's age. Find Raju's age, if his father is 44 years old.
(a) 12 (b) 13 (c) 15 (d) none of these
6. What is that number one third of which added to 5 gives 8?
(a) 11 (b) 10 (c) 9 (d) none of these
7. Find a number such that on adding 4 to eight times of it; you get 60.
(a) 6 (b) 7 (c) 8 (d) none of these
8. Find a number such that one fifth of it minus 4 gives 3.
(a) 45 (b) 25 (c) 35 (d) none of these
9. The solution of the equation $12p - 5 = 25$ is $p =$
(a) $\frac{30}{12}$ (b) $\frac{20}{12}$ (c) 10 (d) none of these
10. The solution of the equation $4(m + 3) = 18$ is $m =$.
(a) $\frac{6}{4}$ (b) 3 (c) $\frac{30}{4}$ (d) none of these
11. The solution of the equation $34 - 5(p - 1) = 4$ is $p =$
(a) 5 (b) 6 (c) 4 (d) 7
12. Nine added to thrice a number a whole number gives 45. Find the number.
(a) 12 (b) 13 (c) 15 (d) none of these
13. Four-fifths of a number is greater than three-fourths of the number by 4. Find the number.
(a) 40 (b) 60 (c) 80 (d) none of these
14. Twice a number when decreased by 7 gives 45. Find the number.
(a) 26 (b) 23 (c) 25 (d) none of these
15. Thrice a number when increased by 5 gives 44. Find the number.
(a) 12 (b) 13 (c) 15 (d) none of these

PRACTICE QUESTIONS
CLASS – VII: CHAPTER – 4
SIMPLE EQUATIONS

1. Write the following statements in the form of equations:
 - (i) The sum of three times x and 11 is 32.
 - (ii) If you subtract 5 from 6 times a number, you get 7.
 - (iii) One fourth of m is 3 more than 7.
 - (iv) One third of a number plus 5 is 8.
2. Convert the following equations in statement form:
 - (i) $x - 5 = 9$ (ii) $5p = 20$ (iii) $3n + 7 = 1$ (iv) $\frac{m}{5} - 2 = 6$.
3. Write the following situation in the form of equations:

Raju's father's age is 5 years more than three times Raju's age. Raju's father is 44 years old. Set up an equation to find Raju's age.
4. A shopkeeper sells mangoes in two types of boxes, one small and one large. A large box contains as many as 8 small boxes plus 4 loose mangoes. Set up an equation which gives the number of mangoes in each small box. The number of mangoes in a large box is given to be 100.
5. Write equations for the following statements:
 - (i) The sum of numbers x and 4 is 9.
 - (ii) The difference between y and 2 is 8.
 - (iii) Ten times a is 70.
 - (iv) The number b divided by 5 gives 6.
 - (v) Three fourth of t is 15.
 - (vi) Seven times m plus 7 gets you 77.
 - (vii) One fourth of a number minus 4 gives 4.
 - (viii) If you take away 6 from 6 times y , you get 60.
 - (ix) If you add 3 to one third of z , you get 30.
6. Write the following statements in the form of equations:
 - (a) 11 added to $2m$ to get 40.
 - (b) 11 subtracted from $2m$ to 25
 - (c) 5 times y to which 3 is added to get 45
 - (d) 5 times y from which 3 is subtracted to get 33
 - (e) y is multiplied by -8 to get 24
 - (f) y is multiplied by -8 and then 5 is added to the result to get 29.
 - (g) y is multiplied by 5 and the result is subtracted from 16 to get 4
 - (h) y is multiplied by -5 and the result is added to 16 to get 8.
7. The length of a rectangular hall is 4 meters less than 3 times the breadth of the hall. What is the length, if the breadth is b meters?
8. Solve: (a) $3n + 7 = 25$ (b) $2p - 1 = 23$ (c) $12p - 5 = 25$
9. Solve: (a) $3n - 2 = 46$ (b) $5m + 7 = 17$ (c) $10p = 100$ (d) $10p + 10 = 100$
(e) $3s = -9$ (f) $3s + 12 = 0$ (g) $2q - 6 = 0$ (h) $2q + 6 = 12$
(i) $\frac{20p}{3} = 40$ (j) $\frac{3p}{10} = 6$ (k) $\frac{3p}{4} = 6$ (l) $\frac{-p}{3} = 2$

10. Solve: (a) $4(m + 3) = 18$ (b) $-2(x + 3) = 5$
11. Solve the following equations.
(a) $4 = 5(p - 2)$ (b) $-4 = 5(p - 2)$ (c) $-16 = -5(2 - p)$
(d) $10 = 4 + 3(t + 2)$ (e) $28 = 4 + 3(t + 5)$ (f) $0 = 16 + 4(m - 6)$
16. The sum of three times a number and 11 is 32. Find the number.
17. Find a number, such that one fourth of the number is 3 more than 7.
18. When you multiply a number by 6 and subtract 5 from the product, you get 7. Find the number.
19. What is that number one third of which added to 5 gives 8?
20. Raju's father's age is 5 years more than three times Raju's age. Find Raju's age, if his father is 44 years old.
21. There are two types of boxes containing mangoes. Each box of the larger type contains 4 more mangoes than the number of mangoes contained in 8 boxes of the smaller type. Each larger box contains 100 mangoes. Find the number of mangoes contained in the smaller box?
22. The teacher tells the class that the highest marks obtained by a student in her class is twice the lowest marks plus 7. The highest score is 87. What is the lowest score?
23. In an isosceles triangle, the base angles are equal. The vertex angle is 40° . What are the base angles of the triangle? (Remember, the sum of three angles of a triangle is 180°).
24. Smita's mother is 34 years old. Two years from now mother's age will be 4 times Smita's present age. What is Smita's present age?
25. Sachin scored twice as many runs as Rahul. Together, their runs fell two short of a double century. How many runs did each one score?
26. Nine added to thrice a number a whole number gives 45. Find the number.
27. Four-fifths of a number is greater than three-fourths of the number by 4. Find the number.
28. Twice a number when decreased by 7 gives 45. Find the number.
29. Thrice a number when increased by 5 gives 44. Find the number.
30. Laxmi's father is 49 years old. He is 4 years older than three times Laxmi's age. What is Laxmi's age?
31. Maya, Madhura and Mohsina are friends studying in the same class. In a class test in geography, Maya got 16 out of 25. Madhura got 20. Their average score was 19. How much did Mohsina score?
32. People of Sundargram planted a total of 102 trees in the village garden. Some of the trees were fruit trees. The number of non-fruit trees were two more than three times the number of fruit trees. What was the number of fruit trees planted?

33. The sum of two consecutive multiples of 3 is 69. Find the numbers.
34. The length of a rectangular plot exceeds its breadth by 5 m. If the perimeter of the plot is 142 m, find the dimensions of the plot.
35. Raju is 19 years younger than his cousin. After 5 years, their ages will be in the ratio 2 : 3. Find their present age.
36. A father is 30 years older than his son. In 12 years, the man will be three times as old as his son. Find their present ages.
37. The ages of Arun and Rahul are in the ratio 7 : 5. Ten years hence, the ratio of their ages will be 9 : 7. Find their present ages.
38. In an examination, a student requires 40% of the total marks to pass. If Vandana gets 185 marks and fails by 15 marks, find the total marks.
39. Five years ago a man was seven times as old as his son. Five years hence, the father will be three times as old as his son. Find their present ages.
40. A sum of Rs. 500 is in the form of denominations of Rs. 5 and Rs. 10. If the total number of notes is 90, find the number of notes of each type.
41. The total cost of 3 tables and 2 chairs is Rs. 745. If a table costs Rs. 40 more than a chair, find the price of each.
42. After 12 years Uday will be 3 times as old as he was 4 years ago. Find his present age.
43. Two-third of a number less than the original number by 10. Find the original number.
44. Solve: $\frac{x+2}{x-2} = \frac{7}{3}$
45. Solve: $\frac{x}{2} + \frac{x}{4} = \frac{1}{8}$
-

MCQ WORKSHEET-I
CLASS – VII: CHAPTER – 5
LINES AND ANGLES

- If two lines intersect at a point, then the vertically opposite angles are always _____.
 (a) equal (b) unequal (c) supplementary (d) complementary
- Two angles forming a linear pair are _____.
 (a) equal (b) supplementary (c) unequal (d) complementary
- A line that intersects two or more lines at distinct points is called
 (a) Parallel (b) transversal (c) intersecting (d) none of these
- If two adjacent angles are supplementary, then they form _____.
 (a) Corresponding angles (b) vertically opposite angles
 (c) a linear pair of angles (d) a ray
- If two angles are supplementary then the sum of their measures is _____.
 (a) 90° (b) 180° (c) 360° (d) 45°
- If two angles are complementary, then the sum of their measures is _____.
 (a) 45° (b) 180° (c) 90° (d) 360°

- If $l \parallel m$, then $\angle 1 = \angle 2$ because they are _____,
 (a) corresponding angles (b) vertically opposite angles
 (c) alternate interior angles (d) supplementary angles

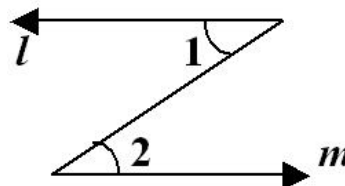

- In fig. pair of alternate interior angles are:
 (a) $\angle 1, \angle 3$ (b) $\angle 2, \angle 3$ (c) $\angle 2, \angle 5$ (d) $\angle 1, \angle 2$

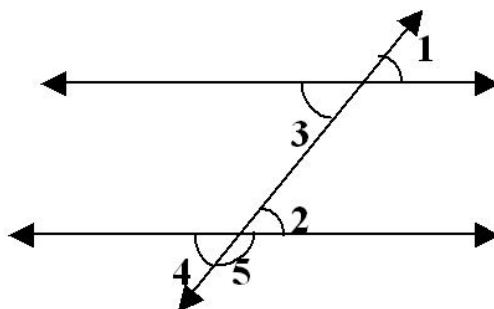

- If two parallel lines are cut by a transversal, each pair of the corresponding angles are _____ in measure.
 (a) equal (b) unequal (c) supplementary (d) complementary

- Line $a \parallel b$, c is a transversal then $\angle y = ?$
 (a) 90° (b) 125° (c) 55° (d) 180°

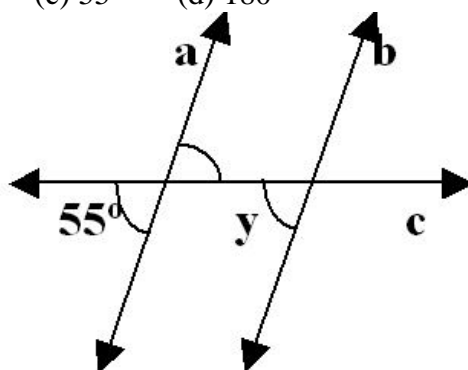

MCQ WORKSHEET-II
CLASS – VII: CHAPTER – 5
LINES AND ANGLES

1. Line $a \parallel b$, c is a transversal then $\angle y = ?$
(a) 90° (b) 25° (c) 55° (d) 35°

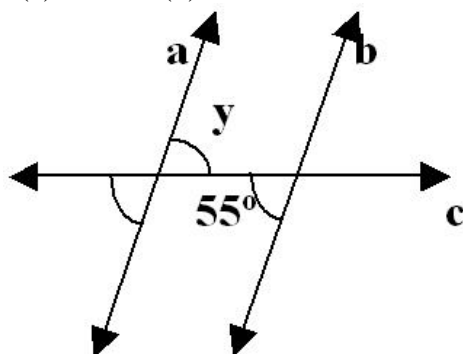

2. In fig. pair of alternate exterior angles are:
(a) $\angle 1, \angle 3$ (b) $\angle 2, \angle 3$ (c) $\angle 2, \angle 5$ (d) $\angle 1, \angle 4$

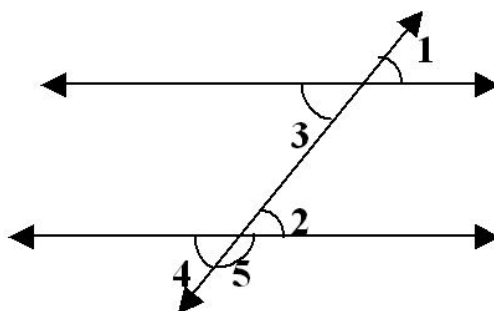

3. The difference in the measures of two complementary angles is 12° . Find the measures of the angles.
(a) 51° and 49° (b) 51° and 39° (c) 60° and 30° (d) 50° and 40°
4. What is the measure of the complement of 45° ?
(a) 135° (b) 25° (c) 35° (d) 45°
5. What is the measure of the complement of 65° ?
(a) 135° (b) 25° (c) 35° (d) 45°
6. What is the measure of the complement of 41° ?
(a) 139° (b) 49° (c) 35° (d) 45°
7. What is the measure of the complement of 54° ?
(a) 126° (b) 49° (c) 35° (d) 41°
8. Identify which of the following pairs of angles are complementary
(a) $65^\circ, 115^\circ$ (b) $63^\circ, 27^\circ$ (c) $112^\circ, 68^\circ$ (d) $130^\circ, 50^\circ$
9. Identify which of the following pairs of angles are supplementary.
(a) $80^\circ, 10^\circ$ (b) $63^\circ, 27^\circ$ (c) $112^\circ, 68^\circ$ (d) $45^\circ, 45^\circ$
10. Find the angle, which is equal to its complement.
(a) 30° (b) 25° (c) 35° (d) 45°

MCQ WORKSHEET-III
CLASS – VII: CHAPTER – 5
LINES AND ANGLES

1. Lines $l \parallel m$, t is a transversal then $\angle x = ?$
 (a) 120° (b) 60° (c) 180° (d) 90°

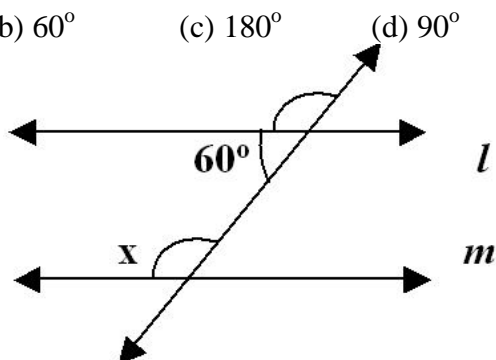

2. Find the angle, which is equal to its supplement.
 (a) 60° (b) 90° (c) 180° (d) none of these

3. Lines $l \parallel m$, t is a transversal then $\angle x = ?$
 (a) 120° (b) 60° (c) 180° (d) 90°

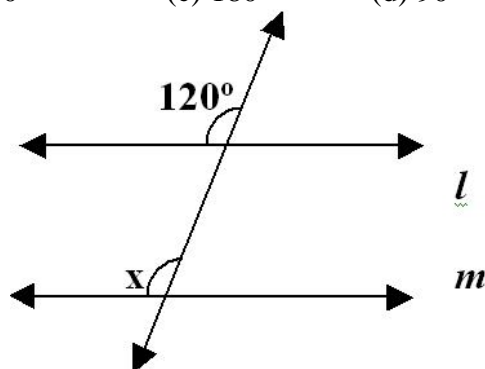

4. Lines $l \parallel m$; t is a transversal $\angle z = ?$
 (a) 120° (b) 60° (c) 180° (d) 90°

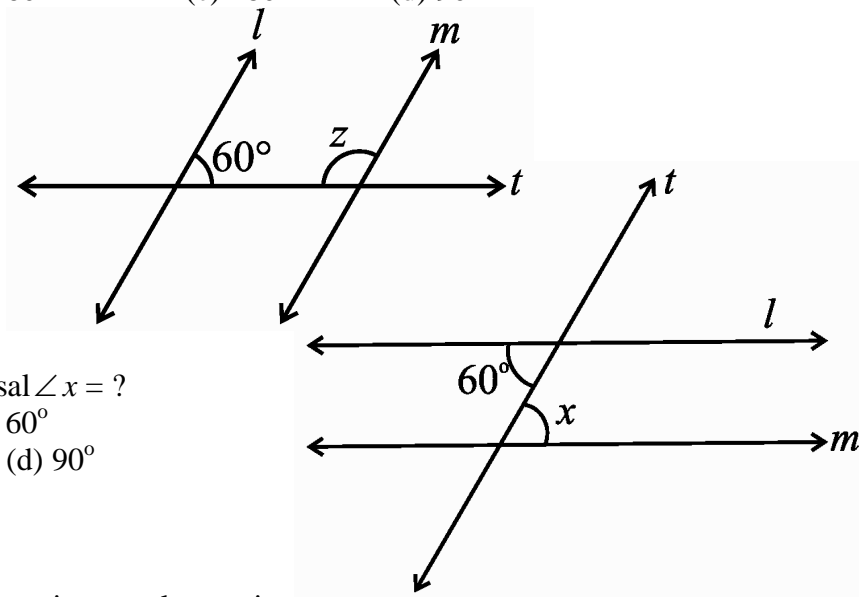

5. Lines $l \parallel m$; t is a transversal $\angle x = ?$
 (a) 120° (b) 60°
 (c) 180° (d) 90°

6. The angle which is four times its complement is
 (a) 60° (b) 30° (c) 45° (d) 72°

7. If arms of two angles are parallel, then find the $\angle DEF$

- (a) 15° (b) 90° (c) 180° (d) 75°

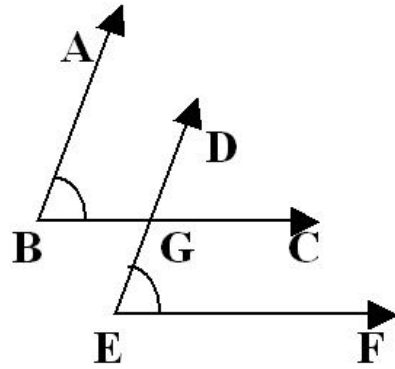

8. The angle which is five times its supplement is

- (a) 150° (b) 180° (c) 90° (d) 360°

9. Find x if $l \parallel m$

- (a) 30° (b) 60° (c) 90° (d) 180°

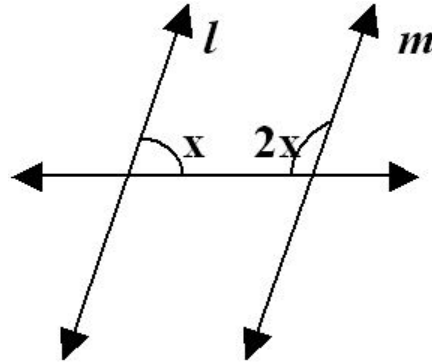

10. Find the value of x if $l \parallel m$

- (a) 110° (b) 70° (c) 90° (d) 180°

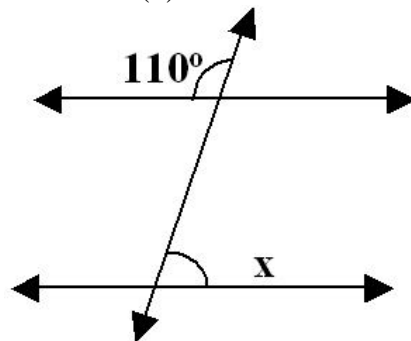

11. Which pair of following angles are complementary ?

- (a) $70^\circ, 20^\circ$ (b) $75^\circ, 25^\circ$ (c) $48^\circ, 52^\circ$ (d) $35^\circ, 55^\circ$

12. Which pair of following angles are supplementary ?

- (a) $110^\circ, 50^\circ$ (b) $105^\circ, 65^\circ$ (c) $50^\circ, 130^\circ$ (d) $45^\circ, 45^\circ$

13. What is complement of 63° ?

- (a) 18° (b) 27° (c) 30° (d) 21°

14. Find the supplement of 105° .

- (a) 80° (b) 65° (c) 75° (d) 100°

15. Two lines PQ and RS intersect at O. If $\angle POR = 50^\circ$, then value of $\angle ROQ$ is

- (a) 120° (b) 130° (c) 90° (d) 150°

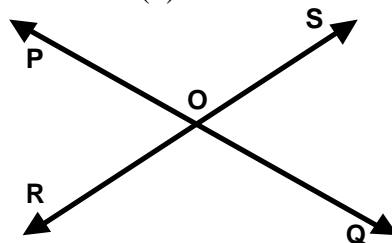

PRACTICE QUESTIONS
CLASS – VII: CHAPTER – 5
LINES AND ANGLES

- What is the measure of the complement of each of the following angles?
 (i) 45° (ii) 65° (iii) 41° (iv) 54°
- The difference in the measures of two complementary angles is 12° . Find the measures of the angles.
- What will be the measure of the supplement of each one of the following angles?
 (i) 100° (ii) 90° (iii) 55° (iv) 125°
- Among two supplementary angles the measure of the larger angle is 44° more than the measure of the smaller. Find their measures.
- In the given figure, if $\angle 1 = 30^\circ$, find $\angle 2$ and $\angle 3$.

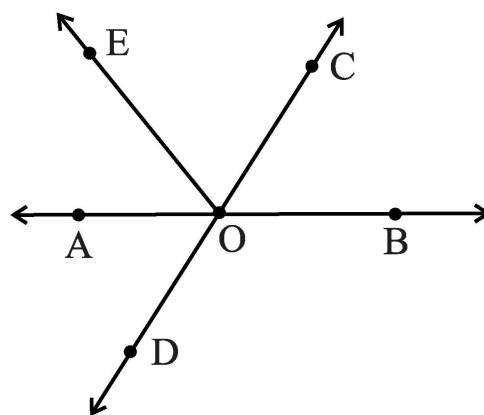
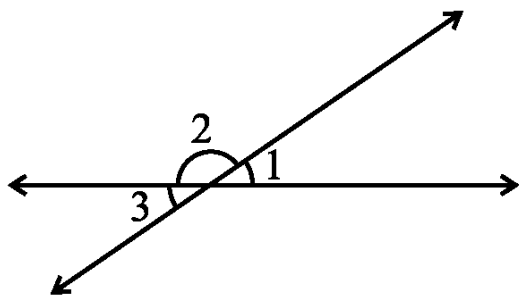

- In Fig identify: (i) Five pairs of adjacent angles. (ii) Three linear pairs. (iii) Two pairs of vertically opposite angles.
- Identify which of the following pairs of angles are complementary and which are supplementary.
 (i) $65^\circ, 115^\circ$ (ii) $63^\circ, 27^\circ$ (iii) $112^\circ, 68^\circ$
 (iv) $130^\circ, 50^\circ$ (v) $45^\circ, 45^\circ$ (vi) $80^\circ, 10^\circ$
- Find the angle which is equal to its complement.
- Find the angle which is equal to its supplement.
- Find the measure of an angle which is 24° more than its complement.
- Find the measure of an angle which is 32° less than its complement.
- Find the measure of an angle, if six times its complement is 12° less than twice its supplement.
- Find the complement of each of the following angles:
 (i) 58° (ii) 160 (iii) $\frac{2}{3}$ of a right angle.
- Find the supplement of each of the following angles:
 (i) 630 (ii) 1380 (iii) $\frac{3}{5}$ of a right angle.
- Find the measure of an angle which is 36° more than its complement.
- Find the measure of an angle which is 25° less than its complement.
- Find the angle which is five times its complement.
- Find the angle which is five times its supplement.
- Find the angle whose supplement is four times its complement.
- Find the angle whose complement is one-third of its supplement.
- Two supplementary angles are in the ratio $3 : 2$. Find the angles.
- Two complementary angles are in the ratio $4 : 5$. Find the angles.
- Find the measure of an angle, if seven times its complement is 10° less than three times its supplement.

24. An angle is greater than 45° . Is its complementary angle greater than 45° or equal to 45° or less than 45° ?

25. In the adjoining figure, name the following pairs of angles.

- (i) Obtuse vertically opposite angles
- (ii) Adjacent complementary angles
- (iii) Equal supplementary angles
- (iv) Unequal supplementary angles
- (v) Adjacent angles that do not form a linear pair

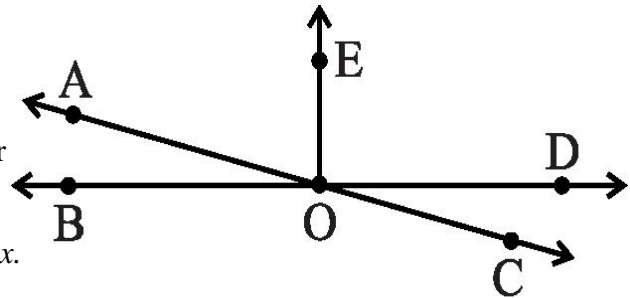

26. Lines $l \parallel m$; t is a transversal Find the value of $\angle x$.

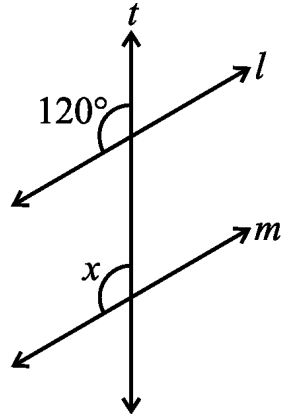

27. Lines $l \parallel m$; t is a transversal. Find the value of $\angle z$

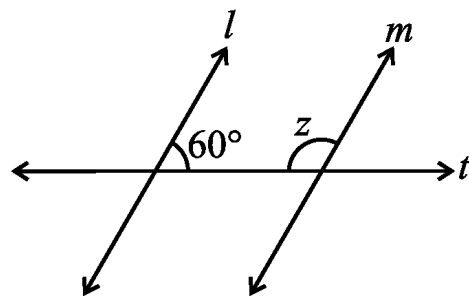

28. Lines $l \parallel m$, $p \parallel q$; Find a , b , c , d

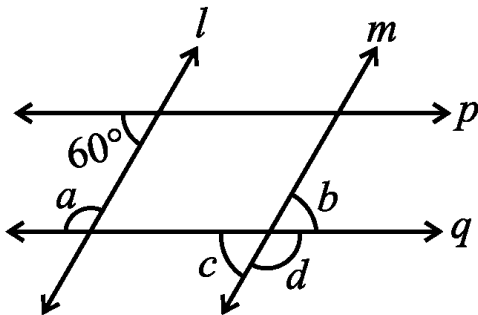

29. Find the value of x in adjoining figure if $l \parallel m$.

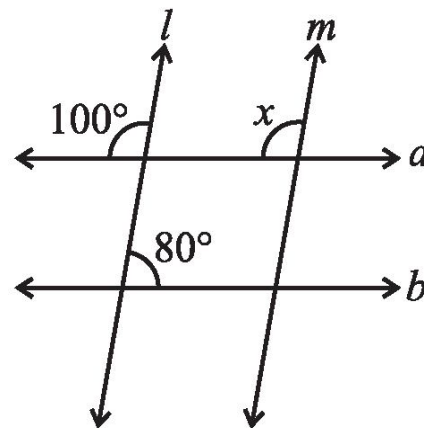

30. Find the value of x in below figure if $l \parallel m$.

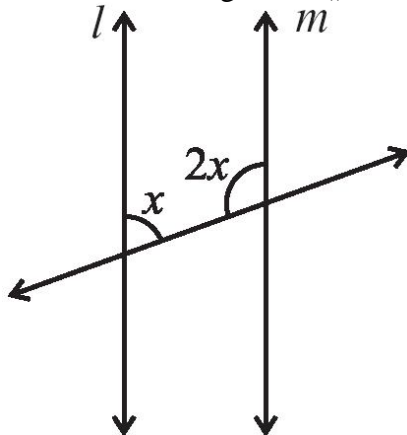

31. In the given figures below, decide whether l is parallel to m .

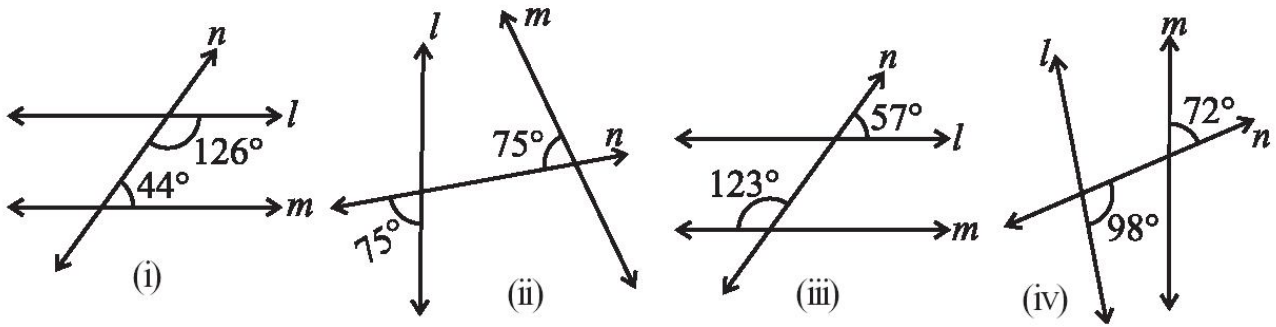

32. In fig, find the value of x

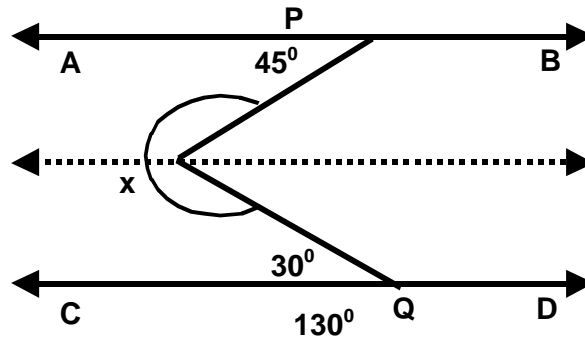

33. In fig, if $PQ \parallel ST$, $\angle PQR = 110^\circ$ and $\angle RST = 130^\circ$ then find the value of $\angle QRS$.

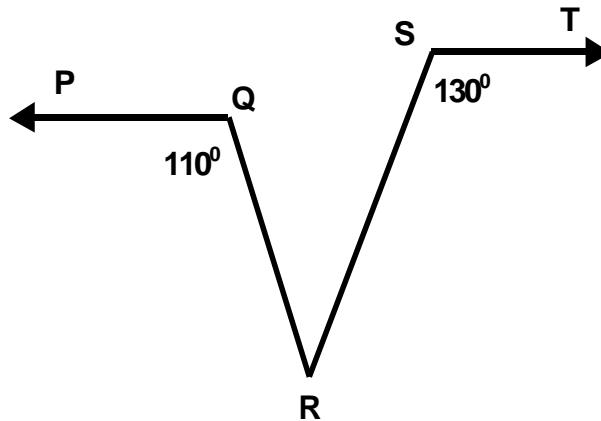

34. In fig., $AB \parallel CD$, $\angle APQ = 50^\circ$, $\angle PRD = 127^\circ$, find the value of x and y respectively are

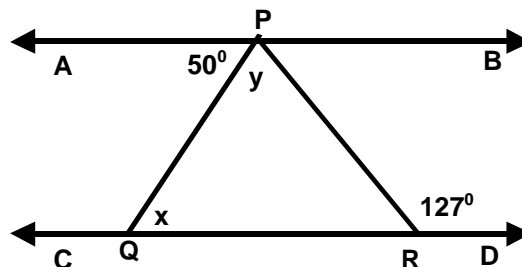

35. Two complementary angles are in the ratio 3 : 6. Find the angles.

MCQ WORKSHEET-I
CLASS – VII: CHAPTER – 6
TRIANGLES AND ITS PROPERTIES

- How many medians a triangle can have?
 (a) 2 (b) 1 (c) 3 (d) 0
- A/an _____ connect a vertex of a triangle to the mid point of the opposite side.
 (a) altitude (b) median (c) vertex (d) none of these
- How many altitude can a triangle have?
 (a) 1 (b) 2 (c) 3 (d) 4

- Angle opposite to the side LM of $\triangle LMN$
 (a) $\angle N$ (b) $\angle L$ (c) $\angle M$ (d) none of these

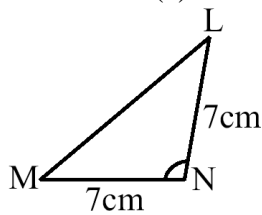

- Side opposite to the vertex Q of $\triangle PQR$
 (a) PQ (b) QR (c) PR (d) none of these

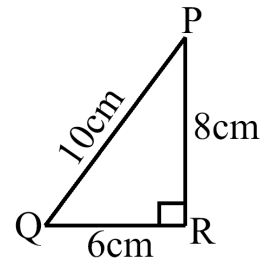

- Vertex opposite to the side RT of $\triangle RST$
 (a) S (b) T (c) R (d) none of these

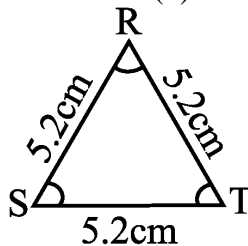

- In $\triangle PQR$, PM is
 (a) Median (b) altitude (c) bisector (d) side

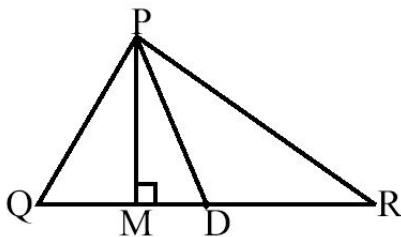

- Find the value of x in the adjoining figure.
 (a) 50° (b) 70° (c) 120° (d) 180°

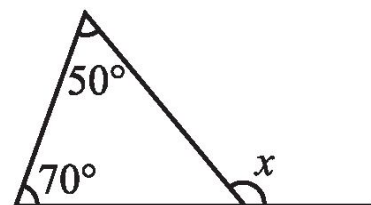

- Find the value of x
 (a) 60° (b) 110° (c) 50° (d) 180°

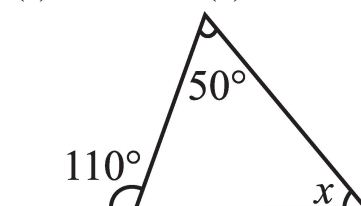

10. Find the value of x
(a) 50° (b) 60° (c) 90° (d) 80°

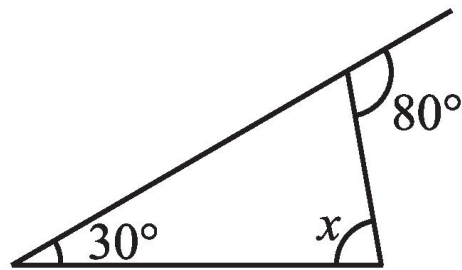

11. A triangle in which two sides are of equal lengths is called _____ .
(a) Equilateral (b) Isosceles (c) Scalene (d) Acute angled triangle
12. The sum of the lengths of any two sides of a triangle is _____ the third side of the triangle.
(a) less than (b) greater than (c) double (d) half
13. In the Pythagoras property , the triangle must be _____ .
(a) acute angled (b) right angled (c) obtuse angled (d) none of these.
14. Find the value of x in this figure.
(a) 40° (b) 60° (c) 35° (d) 180°

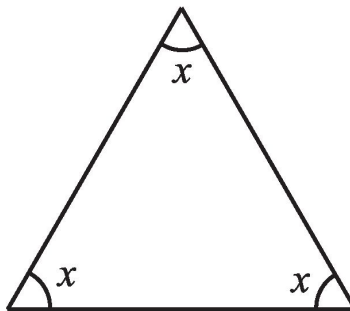

15. Find the value of x in given figure
(a) 180° (b) 55° (c) 90° (d) 60°

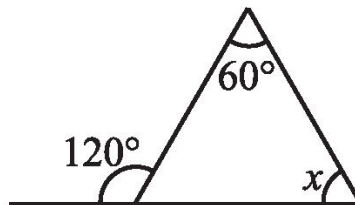

MCQ WORKSHEET-II
CLASS – VII: CHAPTER – 6
TRIANGLES AND ITS PROPERTIES

1. In ΔPQR , PD is
(a) Median (b) altitude (c) bisector (d) side

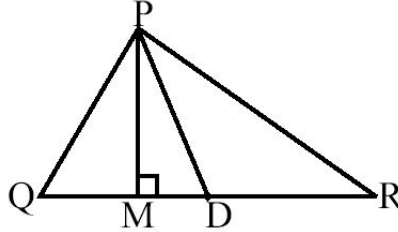

2. The value of x in the adjoining figure is
(a) 125° (b) 90° (c) 180 (d) 35°

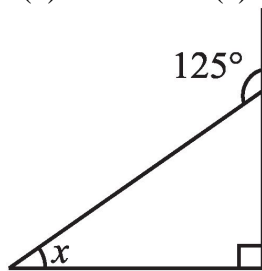

3. Find the value of unknown x in the adjoining figure.
(a) 50° (b) 60° (c) 70° (d) 90°

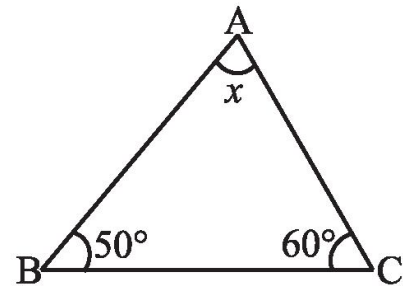

4. What is the value of x in the below figure.
(a) 50° (b) 80° (c) 30° (d) 60°

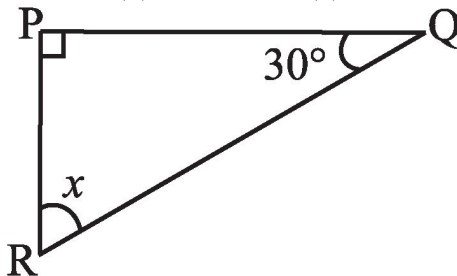

5. What is the measure of angle x
(a) 90° (b) 60° (c) 180° (d) 120°

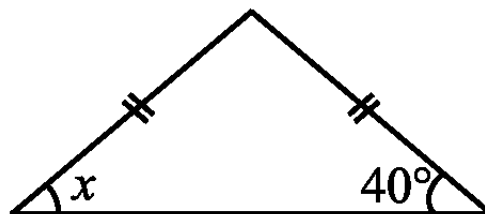

6. ΔABC is right-angled at C . If $AC = 5$ cm and $BC = 12$ cm find the length of AB .
(a) 7 cm (b) 17 cm (c) 13 cm (d) none of these.
7. PQR is a triangle right angled at P . If $PQ = 3$ cm and $PR = 4$ cm, find QR .
(a) 7 cm (b) 1 cm (c) 5 cm (d) none of these.

8. Which is the longest side in the triangle PQR right angled at P?
 (a) PQ (b) QR (c) PR (d) none of these.
9. Which is the longest side in the triangle ABC right angled at B?
 (a) AB (b) BC (c) AC (d) none of these.
10. Which is the longest side of a right triangle?
 (a) perpendicular (b) base (c) hypotenuse (d) none of these.
11. What is the measure of angle x
 (a) 90° (b) 60° (c) 180° (d) 120°

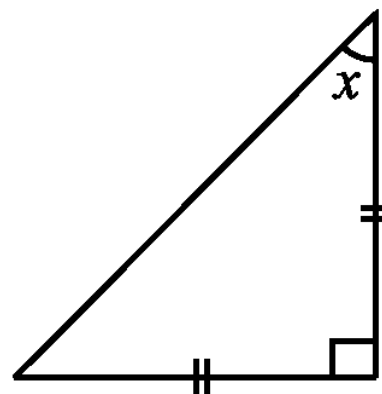
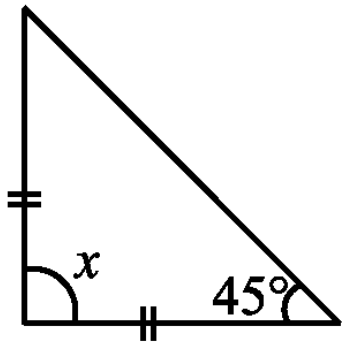

12. The value of x in the adjoining figure is
 (a) 25° (b) 90° (c) 45 (d) 35°

13. A triangle in which all three sides are of equal lengths is called _____.
 (a) Equilateral (b) Isosceles (c) Scalene (d) Acute angled triangle

14. Find angle x in below figure:
 (a) 25° (b) 90° (c) 40 (d) 30°

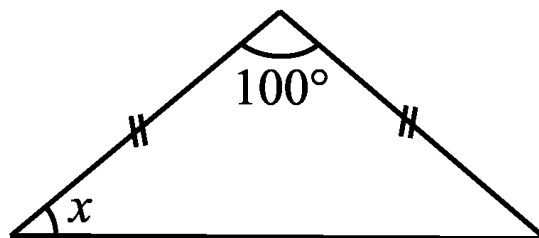

15. Find angle x in below figure:
 (a) 90° (b) 60° (c) 80° (d) 40°

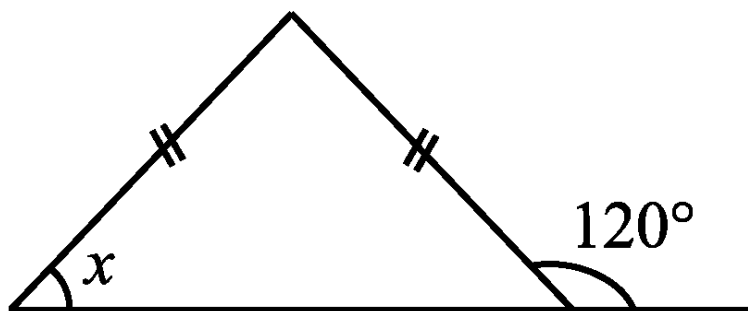

MCQ WORKSHEET-III
CLASS – VII: CHAPTER – 6
TRIANGLES AND ITS PROPERTIES

- In a $\triangle ABC$, $\angle A = 35^\circ$ and $\angle B = 65^\circ$, then the measure of $\angle C$ is
(a) 50° (b) 80° (c) 30° (d) 60°
- The hypotenuse of a right triangle is 17 cm long. If one of the remaining two sides is 8 cm in length, then the length of the other side is
(a) 15 cm (b) 12 cm (c) 13 cm (d) none of these.
- How many acute angles can a right triangle have?
(a) 1 (b) 2 (c) 3 (d) 0
- Find the unknown length x in the adjoining figure.

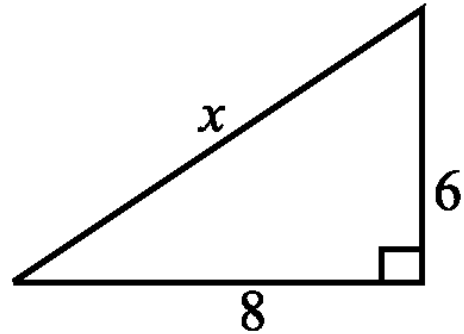

- In a $\triangle PQR$, $\angle R = 105^\circ$ and $\angle Q = 40^\circ$, then the measure of $\angle P$ is
(a) 45° (b) 80° (c) 30° (d) 60°
- In a $\triangle ABC$, $\angle A = 72^\circ$ and $\angle B = 63^\circ$, then the measure of $\angle C$ is
(a) 45° (b) 80° (c) 30° (d) 60°
- In a $\triangle XYZ$, $\angle X = 90^\circ$ and $\angle Z = 48^\circ$, then the measure of $\angle Y$ is
(a) 45° (b) 40° (c) 41° (d) 42°
- One of the acute angle of a right triangle is 36° , then the other acute angle is
(a) 55° (b) 54° (c) 51° (d) 52°
- Find the unknown length x in the adjoining figure.
(a) 5 (b) 7 (c) 3 (d) 4
- Find the unknown length x in the below figure.

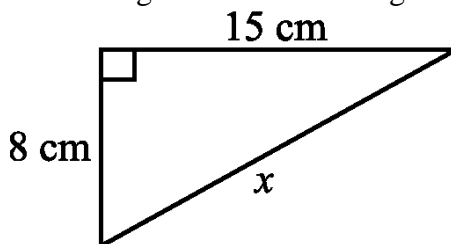
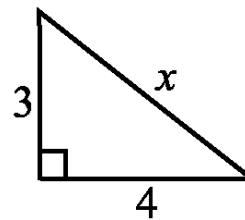

- (a) 15 (b) 17 (c) 13 (d) 14
- The acute angles of right triangle are in the ratio 2 : 1. Find the measure of each of these angles.
(a) 55° and 35° (b) 60° and 30° (c) 50° and 40° (d) 45° and 45°
- One of the angles of a triangle is 100° and the other two angles are equal. Find the measure of each of these equal angles.
(a) 45° (b) 40° (c) 41° (d) 42°

PRACTICE QUESTIONS
CLASS – VII: CHAPTER – 6
TRIANGLES AND ITS PROPERTIES

- Write the six elements (i.e., the 3 sides and the 3 angles) of $\triangle ABC$.
- Write the:
 - Side opposite to the vertex Q of $\triangle PQR$
 - Angle opposite to the side LM of $\triangle LMN$
 - Vertex opposite to the side RT of $\triangle RST$
- In $\triangle PQR$ given in the adjoining figure, D is the mid-point of \overline{QR} .

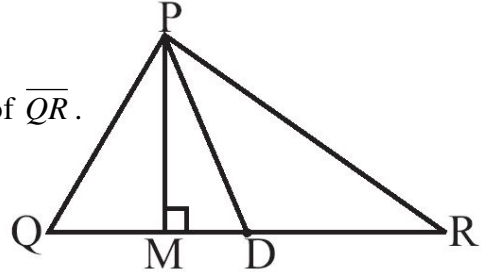

\overline{PM} is _____
 \overline{PD} is _____
 Is $QM = MR$?

- Prove that “An exterior angle of a triangle is equal to the sum of its interior opposite angles”.
- An exterior angle of a triangle is of measure 70° and one of its interior opposite angles is of measure 25° . Find the measure of the other interior opposite angle.
- The two interior opposite angles of an exterior angle of a triangle are 60° and 80° . Find the measure of the exterior angle.
- Find the value of x in the adjoining figure.

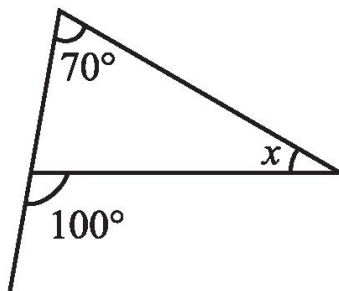

- Find the value of x in the adjoining figure.
- Find the value of x in the below figure.

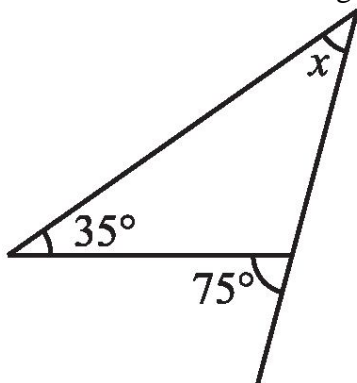
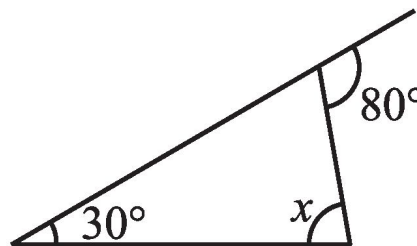

- Find the value of x in the adjoining figure.

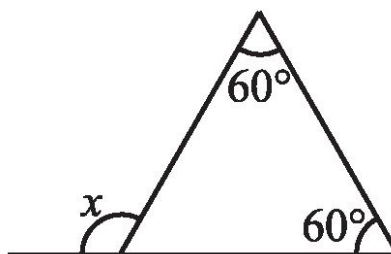

- An exterior angle of a triangle is of measure 113° and one of its interior opposite angles is of measure 25° . Find the measure of the other interior opposite angle.
- The two interior opposite angles of an exterior angle of a triangle are 49° and 41° . Find the measure of the exterior angle.

13. Prove that "The sum of all interior angles of a triangle is 180° ".

14. In the given figure, find $m\angle P$.

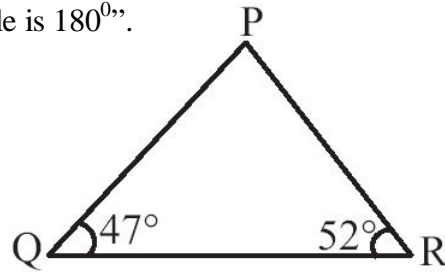

15. Two angles of a triangle are 30° and 80° . Find the third angle.

16. One of the angles of a triangle is 80° and the other two angles are equal. Find the measure of each of the equal angles.

17. The three angles of a triangle are in the ratio 1:2:1. Find all the angles of the triangle.

18. Find the value of the unknown x in the below figure.

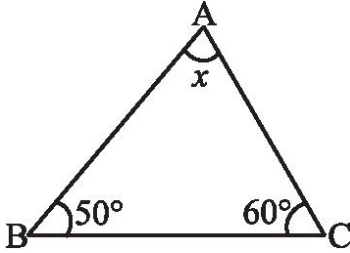

19. Find the value of the unknown x in the adjoining figure.

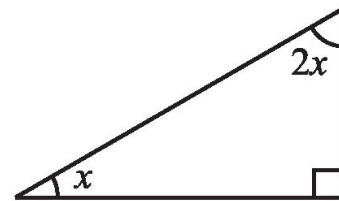

20. Find the value of the unknown x in the below figure.

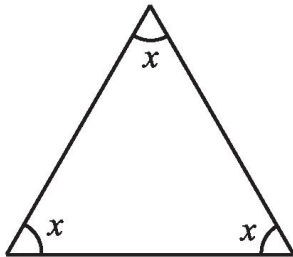

21. Find the value of x and y in the adjoining figure.

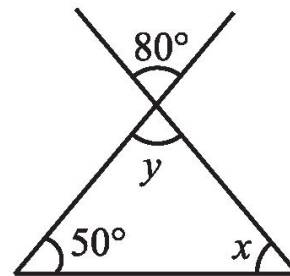

22. Find the value of x and y in the below figure.

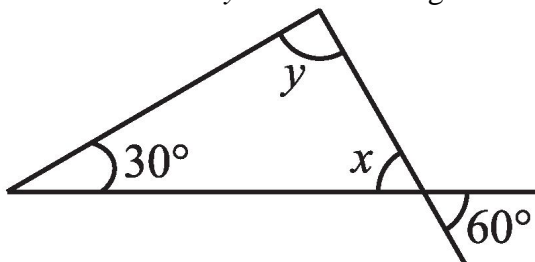

23. Find the value of x and y in the adjoining figure.

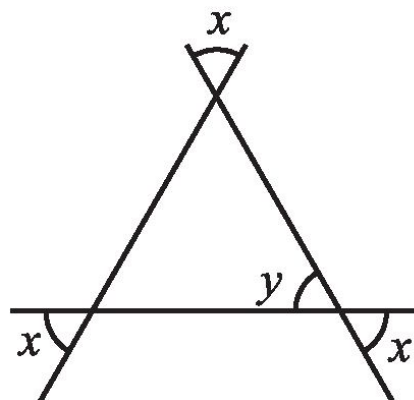

24. Is there a triangle whose sides have lengths 10.2 cm, 5.8 cm and 4.5 cm?
 25. The lengths of two sides of a triangle are 6 cm and 8 cm. Between which two numbers can length of the third side fall?
 26. AM is a median of a triangle ABC. Is $AB + BC + CA > 2 AM$?
 (Consider the sides of triangles ABM and AMC.)

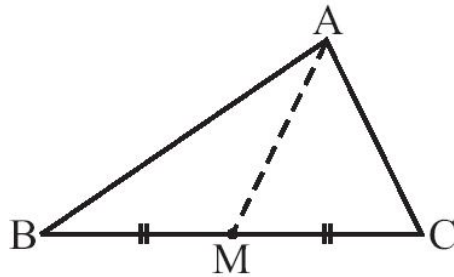

27. ABCD is a quadrilateral. Is $AB + BC + CD + DA > AC + BD$?

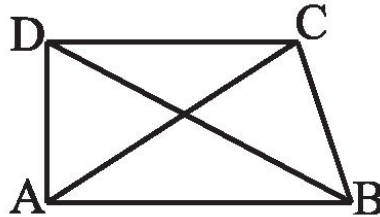

28. ABCD is quadrilateral. Is $AB + BC + CD + DA < 2 (AC + BD)$?

29. The lengths of two sides of a triangle are 12 cm and 15 cm. Between what two measures should the length of the third side fall?

30. Determine whether the triangle whose lengths of sides are 3 cm, 4 cm, 5 cm is a right-angled triangle.

31. $\triangle ABC$ is right-angled at C. If $AC = 5$ cm and $BC = 12$ cm find the length of AB.

32. Find the value of x in the below figure.

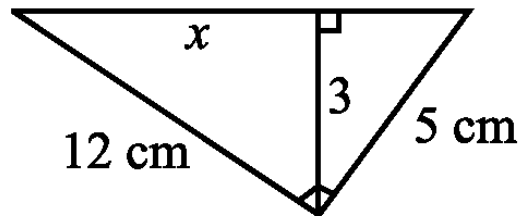
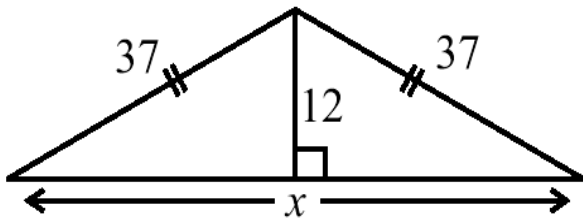

33. Find the value of x in the adjoining figure.

34. Find the value of x in the below figure.

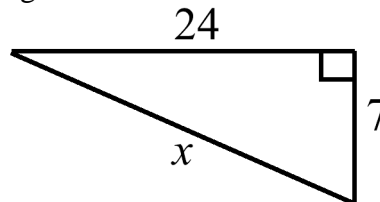

35. PQR is a triangle right angled at P. If $PQ = 10$ cm and $PR = 24$ cm, find QR.

36. ABC is a triangle right angled at C. If $AB = 25$ cm and $AC = 7$ cm, find BC.

37. A 15 m long ladder reached a window 12 m high from the ground on placing it against a wall at a distance a. Find the distance of the foot of the ladder from the wall.

38. A tree is broken at a height of 5 m from the ground and its top touches the ground at a distance of 12 m from the base of the tree. Find the original height of the tree.

39. Find the perimeter of the rectangle whose length is 40 cm and a diagonal is 41 cm.

40. The diagonals of a rhombus measure 16 cm and 30 cm. Find its perimeter.



MCQ WORKSHEET-I
CLASS VII: CHAPTER - 7
CONGRUENCE OF TRIANGLES

1. Two angles are congruent if they have
(a) same name (b) Equal measures (c) Unequal measures (d) None of these
 2. Which of the following is not a congruence criterion-?
(a) SSS (b) SAS (c) ASA (d) None of these
 3. If a $\triangle ABC \cong \triangle PQR$, then AB is equal to –
(a)QR (b) PQ (c) PR (d) None of these
 4. In $\triangle ABC$ and $\triangle PQR$, AB=4cm, BC=5 cm, AC=6 cm and PQ=4cm, QR=5 cm, PR=6 cm, then which of the following is true-
(a) $\triangle ABC \cong \triangle QRP$ (c) $\triangle ABC \cong \triangle PQR$
(b) $\triangle ABC \cong \triangle PRQ$ (d) $\triangle ABC \cong \triangle QPR$
 5. If $\triangle DEF \cong \triangle BCA$, then the part of $\triangle BCA$ that correspond to $\angle E$ is
(a) $\angle A$ (b) $\angle B$ (c) $\angle C$ (d) none of these
 6. If $\triangle DEF \cong \triangle ACB$, then the part of $\triangle ACB$ that correspond to $\angle F$ is
(a) $\angle A$ (b) $\angle B$ (c) $\angle C$ (d) none of these
 7. $\triangle ABC$ and $\triangle PQR$ are congruent under the correspondence: $ABC \leftrightarrow RQP$, then the part of $\triangle ABC$ that correspond to $\angle P$ is
(a) $\angle A$ (b) $\angle B$ (c) $\angle C$ (d) none of these
 8. $\triangle ABC$ and $\triangle PQR$ are congruent under the correspondence: $ABC \leftrightarrow RQP$, then the part of $\triangle ABC$ that correspond to $\angle Q$ is
(a) $\angle A$ (b) $\angle B$ (c) $\angle C$ (d) none of these
 9. $\triangle ABC$ and $\triangle PQR$ are congruent under the correspondence: $ABC \leftrightarrow RPQ$, then the part of $\triangle ABC$ that correspond to \overline{PQ} is
(a) \overline{AB} (b) \overline{BC} (c) \overline{CA} (d) none of these
 10. $\triangle ABC$ and $\triangle PQR$ are congruent under the correspondence: $BCA \leftrightarrow RPQ$, then the part of $\triangle ABC$ that correspond to \overline{PQ} is
(a) \overline{AB} (b) \overline{BC} (c) \overline{CA} (d) none of these
 11. $\triangle ABC$ and $\triangle PQR$ are congruent under the correspondence: $BAC \leftrightarrow RPQ$, then the part of $\triangle ABC$ that correspond to \overline{PR} is
(a) \overline{AB} (b) \overline{BC} (c) \overline{CA} (d) none of these
 12. What is the side included between the angles A and B in $\triangle ABC$?
(a) \overline{AB} (b) \overline{BC} (c) \overline{CA} (d) none of these
-

MCQ WORKSHEET-II
CLASS VII: CHAPTER - 7
CONGRUENCE OF TRIANGLES

1. In the below quadrilateral ABCD, $AD = BC$ and $\angle DAB = \angle CBA$. If $\triangle ABD \cong \triangle BAC$. The relation between $\angle ABD$ and $\angle BAC$ is
 (a) $\angle ABD > \angle BAC$ (b) $\angle ABD < \angle BAC$
 (c) $\angle ABD = \angle BAC$ (d) $\angle ABD = \frac{1}{2} \angle BAC$

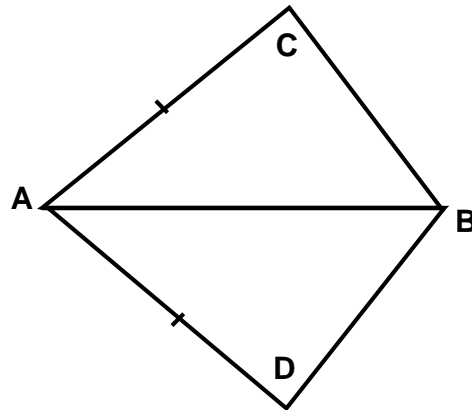
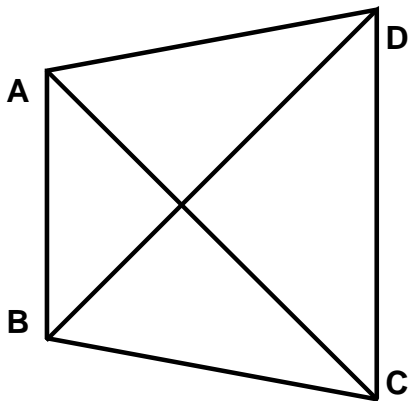

2. In the above sided quadrilateral ABCD, $AC = AD$ and AB bisect $\angle A$ and $\triangle ABC \cong \triangle ABD$. The relation between BC and BD is

- (a) $BC > BD$ (b) $BC < BD$ (c) $BC = BD$ (d) $BC = \frac{1}{2} BD$

3. In the below fig. AC and BD are equal perpendicular to line segment AB. If $\triangle BOC \cong \triangle AOD$, then the relation between OC and OD is

- (a) $OD > OC$ (b) $OD < OC$ (c) $OD = OC$ (d) $OD = \frac{1}{2} OC$

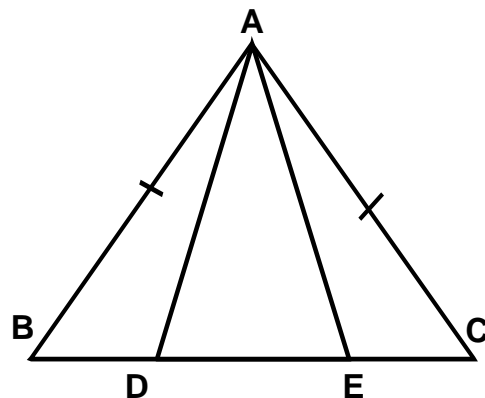
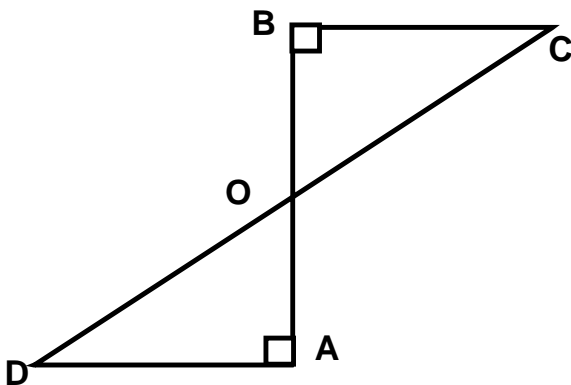

4. In the above sided fig. $AB = AC$ and $BF = CD$. If $\triangle ACD \cong \triangle ABE$ then $AD =$
 (a) AC (b) AE (c) AB (d) none of these

5. $\triangle ABC$ is right triangle in which $\angle A = 90^\circ$ and $AB = AC$. The values of $\angle B$ and $\angle C$ will be
 (a) $\angle B = \angle C = 60^\circ$ (b) $\angle B = \angle C = 30^\circ$
 (c) $\angle B = \angle C = 45^\circ$ (d) $\angle B = \angle C = 50^\circ$

6. The measure of each angle of an equilateral triangle is:
 (a) 60° (b) 30° (c) 45° (d) 40°

7. If the vertical angle of a isosceles triangle is 40° then measure of other two angles will be
 (a) $60^\circ, 60^\circ$ (b) $70^\circ, 70^\circ$ (c) $50^\circ, 50^\circ$ (d) $75^\circ, 75^\circ$
8. If $\angle A, \angle B$ and $\angle C$ of $\triangle ABC$ are equal then triangle is:
 (a) Equilateral (b) Isosceles (c) Scalene (d) none of these.
9. Which one of the following is the value of congruency?
 (a) SAS (b) ASS (c) SSA (d) none of these
10. By which congruence rule following triangles are congruent ?
 (a) SAS (b) RHS (c) ASA (d) SSS

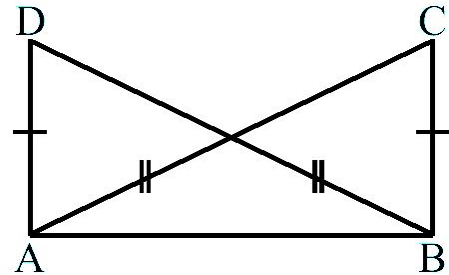
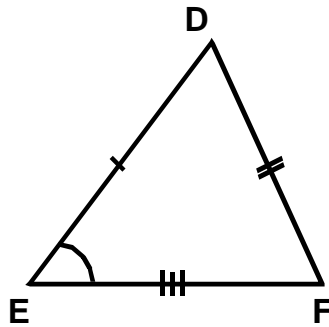
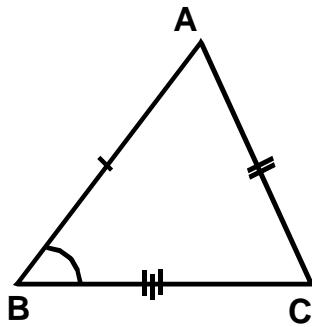

11. In the above sided Fig , $AC = BD$ and $AD = BC$. Which of the following statements is meaningfully written?
 a) $\triangle ABC \cong \triangle ABD$ b) $\triangle ABC \cong \triangle BDA$. c) $\triangle ABC \cong \triangle BAD$ d) $\triangle ABC \cong \triangle ADB$
12. What is the angle included between the sides PN and PM of $\triangle MNP$?
 (a) $\angle N$ (b) $\angle P$ (c) $\angle M$ (d) none of these

MCQ WORKSHEET-III
CLASS VII: CHAPTER - 7
CONGRUENCE OF TRIANGLES

1. In triangles ABC and PQR, AB = 3.5 cm, BC = 7.1 cm, AC = 5 cm, PQ = 7.1 cm, QR = 5 cm and PR = 3.5 cm, then which of the following is true-
- a) $\triangle ABC \cong \triangle QRP$ c) $\triangle ABC \cong \triangle PQR$
c) $\triangle ABC \cong \triangle RPQ$ d) $\triangle ABC \cong \triangle QPR$

2. In triangles ABC and DEF, AB = 7 cm, BC = 5 cm, $\angle B = 50^\circ$ DE = 5 cm, EF = 7 cm, $\angle E = 50^\circ$ By which congruence rule the triangles are congruent ?
- (a) SAS (b) RHS (c) ASA (d) SSS

3. In the below Fig, AB = AC and AD is the bisector of $\angle BAC$, then the relation between $\angle B$ and $\angle C$ is
- (a) $\angle B > \angle C$ (b) $\angle ABD < \angle C$ (c) $\angle B = \angle C$ (d) $\angle ABD = \frac{1}{2} \angle C$

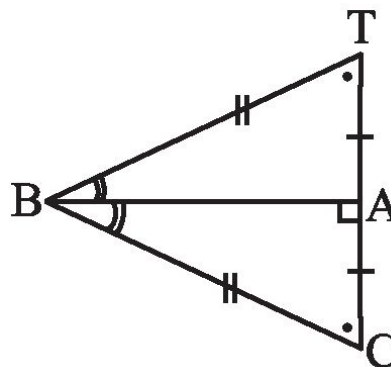
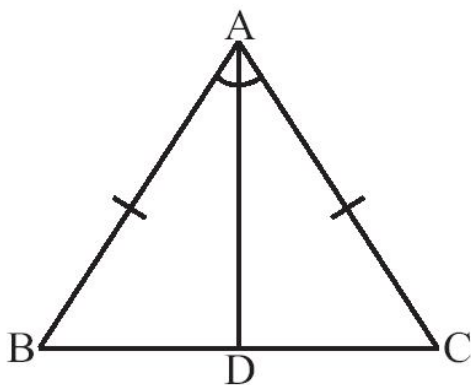

4. In the above-sided figure, complete the congruence statement: $\triangle BCA \cong ?$
- (a) $\triangle BTA$ (b) $\triangle BAT$ (c) $\triangle TAB$ (d) $\triangle ATB$
5. What is the side included between the angles M and N of $\triangle MNP$?
- (a) MN (b) NP (c) PM (d) none of these
6. In triangles DEF and PQR, $\angle D = 60^\circ$, $\angle F = 80^\circ$, DF = 5 cm, $\angle Q = 60^\circ$, $\angle R = 80^\circ$, QR = 5cm. By which congruence rule the triangles are congruent ?
- (a) SAS (b) RHS (c) ASS (d) none of these
7. In triangles ABC and DEF, BC = 6 cm, AC = 4 cm, $\angle B = 35^\circ$ DF = 4 cm, EF = 6 cm, $\angle E = 35^\circ$, By which congruence rule the triangles are congruent ?
- (a) SAS (b) RHS (c) ASS (d) none of these
8. What is the angle included between the sides MN and NP of $\triangle MNP$?
- (a) $\angle N$ (b) $\angle P$ (c) $\angle M$ (d) none of these
9. Two line segments are congruent if they have
- a) same name b) Equal measures c) Unequal measures d) None of these

10. What is the side included between the angles A and C of $\triangle ABC$?

- (a) AB (b) BC (c) CA (d) none of these

11. In the below figure, complete the congruence statement: $\triangle QRS \cong ?$

- (a) $\triangle PQT$ (b) $\triangle TPQ$ (c) $\triangle TQP$ (d) none of these

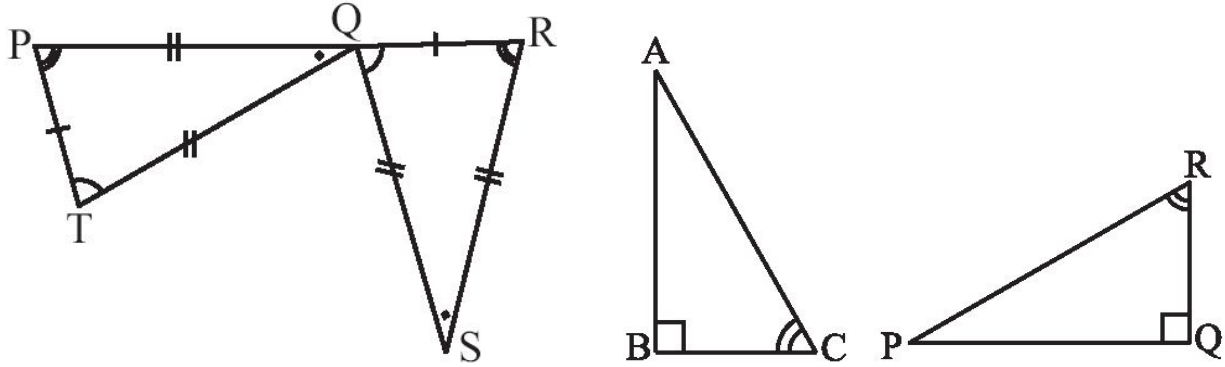

12. If $\triangle ABC$ and $\triangle PQR$ are to be congruent, name one additional pair of corresponding parts.

- (a) $AB = PQ$ (b) $\angle A = \angle P$ (c) $BC = QR$ (d) none of these



MCQ WORKSHEET-IV
CLASS VII: CHAPTER - 7
CONGRUENCE OF TRIANGLES

1. By which congruence rule following triangles are congruent ?

- (a) SAS (b) RHS (c) ASA (d) SSS

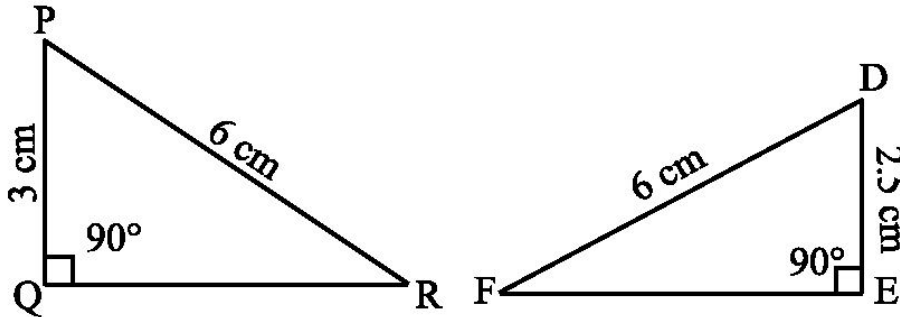

2. In the below figure, by which congruence rule the following triangles are congruent?

- (a) SAS (b) RHS (c) ASA (d) SSS

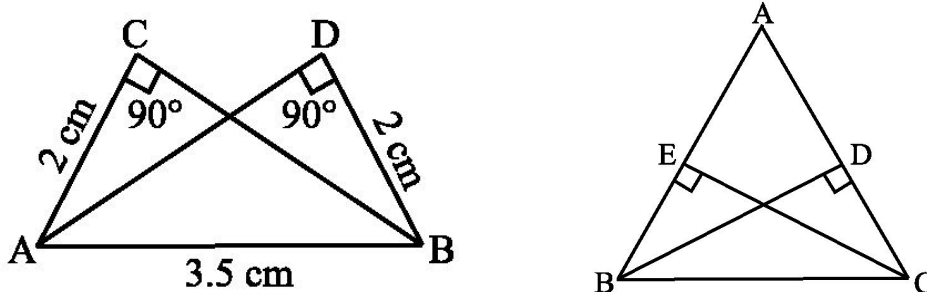

3. In the above sided Fig, BD and CE are altitudes of $\triangle ABC$ such that $BD = CE$ then by which congruence rule $\triangle CBD \cong \triangle BCE$?

- (a) SAS (b) RHS (c) ASA (d) SSS

4. It is to be established by RHS congruence rule that $\triangle ABC \cong \triangle RPQ$. What additional information is needed, if it is given that $\angle B = \angle P = 90^\circ$ and $AB = RP$?

- (a) $AC = RQ$ (b) $\angle A = \angle P$ (c) $BC = QR$ (d) none of these

5. If ABC and DEF are congruent triangles such that $\angle A = 47^\circ$ and $\angle E = 83^\circ$, then $\angle C =$

- (a) 50° (b) 60° (c) 70° (d) 80°

6. In congruent triangles ABC and DEF, $\angle A = \angle E = 40^\circ$, and $\angle F = 65^\circ$, then $\angle B =$

- (a) 35° (b) 65° (c) 75° (d) 85°

7. In the below figure, if $EF = QR$ then the congruence rule used for the congruency of the given triangles is

- (a) AAA (b) SSS (c) SAS (d) ASA

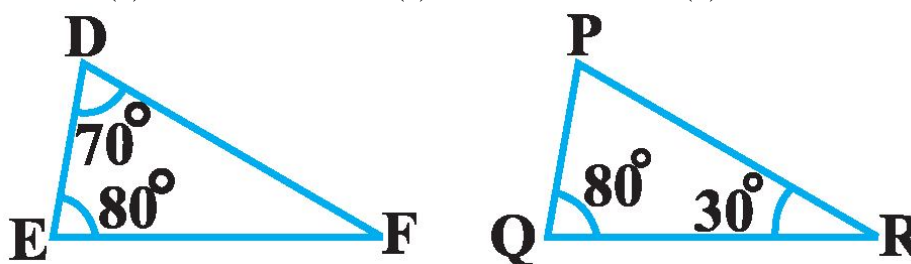

8. In the below figure, by which congruence rule the following triangles are congruent?
 (a) SAS (b) RHS (c) ASA (d) SSS

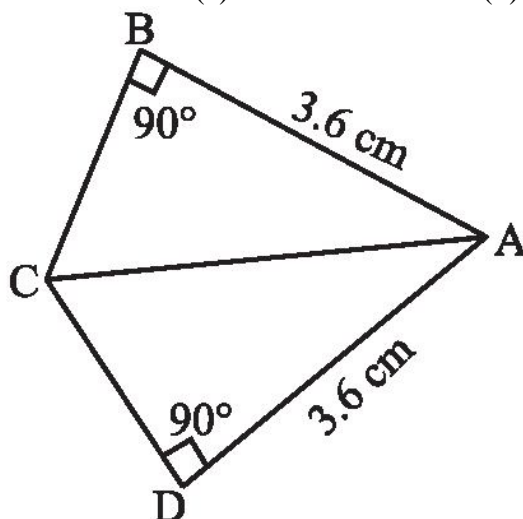

9. In triangles ABC and PQR, $\angle B = 90^\circ$, $AC = 8$ cm, $AB = 3$ cm, $\angle P = 90^\circ$, $PR = 3$ cm, $QR = 8$ cm
 By which congruence rule the triangles are congruent ?
 (a) SAS (b) RHS (c) ASS (d) none of these

10. In triangles DEF and PQR, $\angle E = 80^\circ$, $\angle F = 30^\circ$, $EF = 5$ cm, $\angle P = 80^\circ$, $PQ = 5$ cm, $\angle R = 30^\circ$, By which congruence rule the triangles are congruent ?
 (a) SAS (b) RHS (c) ASS (d) none of these

11. In the below figure, by which congruence rule the following triangles are congruent?
 (a) SAS (b) RHS (c) ASA (d) SSS

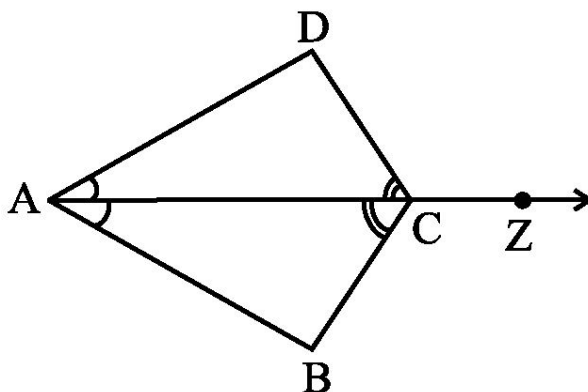

12. You want to establish $\triangle DEF \cong \triangle MNP$, using the ASA congruence rule. You are given that $\angle D = \angle M$ and $\angle F = \angle P$. What information is needed to establish the congruence?
 (a) $DF = MP$ (b) $\angle E = \angle N$ (c) $DE = MN$ (d) none of these



PRACTICE QUESTIONS
CLASS VII: CHAPTER - 7
CONGRUENCE OF TRIANGLES

- $\triangle ABC$ and $\triangle PQR$ are congruent under the correspondence: $ABC \leftrightarrow RQP$. Write the parts of $\triangle ABC$ that correspond to (i) $\angle P$ (ii) $\angle Q$ (iii) \overline{RP}
- Complete the following statements:
 (a) Two line segments are congruent if _____.
 (b) Among two congruent angles, one has a measure of 70° ; the measure of the other angle is _____.
 (c) When we write $\angle A = \angle B$, we actually mean _____.
- If $\triangle ABC \cong \triangle FED$ under the correspondence $ABC \leftrightarrow FED$, write all the corresponding congruent parts of the triangles.
- If $\triangle DEF \cong \triangle BCA$, write the part(s) of BCA that correspond to (i) $\angle E$ (ii) EF (iii) $\angle F$ (iv) DF

- In triangles ABC and PQR , $AB = 3.5$ cm, $BC = 7.1$ cm, $AC = 5$ cm, $PQ = 7.1$ cm, $QR = 5$ cm and $PR = 3.5$ cm. Examine whether the two triangles are congruent or not. If yes, write the congruence relation in symbolic form.

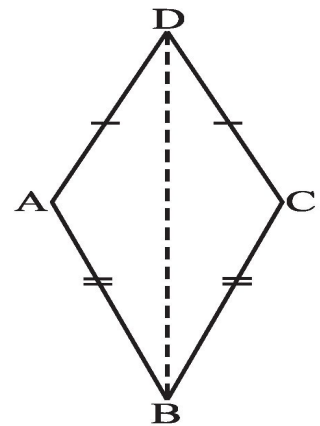

- In Fig $AD = CD$ and $AB = CB$.
 (i) State the three pairs of equal parts in $\triangle ABD$ and $\triangle CBD$.
 (ii) Is $\triangle ABD \cong \triangle CBD$? Why or why not?
 (iii) Does BD bisect $\angle ABC$? Give reasons.

- Explain, why $\triangle ABC \cong \triangle FED$ (see below figure).

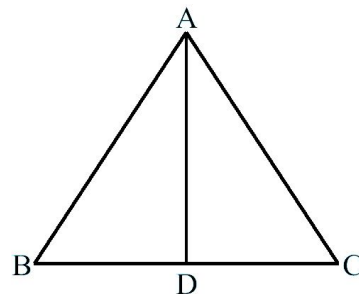
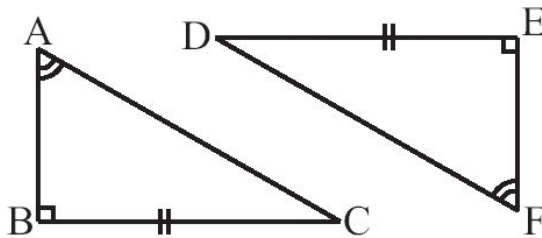

- In the above sided Fig, $AB = AC$ and D is the mid-point of BC
 (i) State the three pairs of equal parts in $\triangle ADB$ and $\triangle ADC$.
 (ii) Is $\triangle ADB \cong \triangle ADC$? Give reasons.
 (iii) Is $\angle B = \angle C$? Why?
- Which angle is included between the sides DE and EF of $\triangle DEF$?
- By applying ASA congruence rule, it is to be established that $\triangle ABC \cong \triangle QRP$ and it is given that $BC = RP$. What additional information is needed to establish the congruence?

11. In Fig, $AC = BD$ and $AD = BC$. Which of the following statements is meaningfully written?
 (i) $\triangle ABC \cong \triangle ABD$ (ii) $\triangle ABC \cong \triangle BAD$.

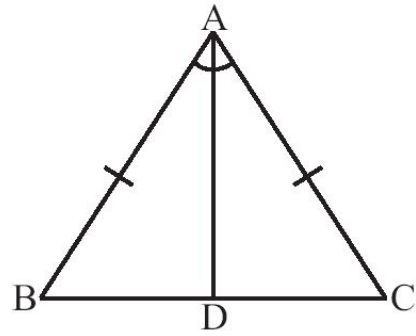
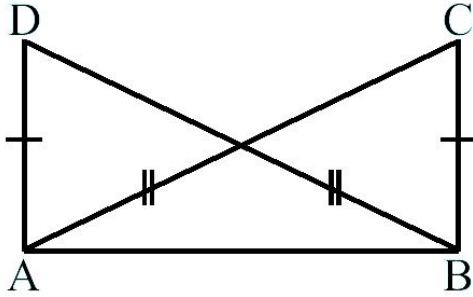

12. In the above sided Fig, $AB = AC$ and AD is the bisector of $\angle BAC$.
 (i) State three pairs of equal parts in triangles ADB and ADC .
 (ii) Is $\triangle ADB \cong \triangle ADC$? Give reasons.
 (iii) Is $\angle B = \angle C$? Give reasons.

13. In the below Fig, AB and CD bisect each other at O .
 (i) State the three pairs of equal parts in two triangles AOC and BOD .
 (ii) Which of the following statements are true?
 (a) $\triangle AOC \cong \triangle DOB$ (b) $\triangle AOC \cong \triangle BOD$

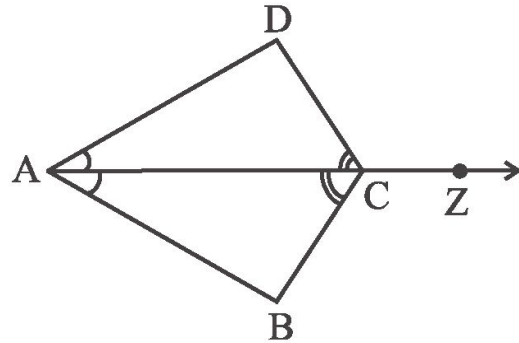
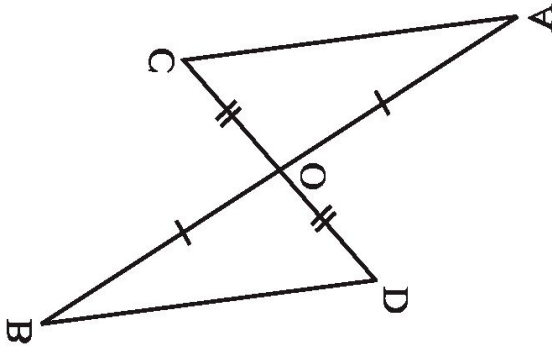

14. In the above sided Fig, ray AZ bisects $\angle DAB$ as well as $\angle DCB$.
 (i) State the three pairs of equal parts in triangles BAC and DAC .
 (ii) Is $\triangle BAC \cong \triangle DAC$? Give reasons.
 (iii) Is $AB = AD$? Justify your answer.
 (iv) Is $CD = CB$? Give reasons.

15. In Fig, $DA \perp AB$, $CB \perp AB$ and $AC = BD$. State the three pairs of equal parts in $\triangle ABC$ and $\triangle DAB$. Which of the following statements is meaningful?
 (i) $\triangle ABC \cong \triangle BAD$ (ii) $\triangle ABC \cong \triangle ABD$

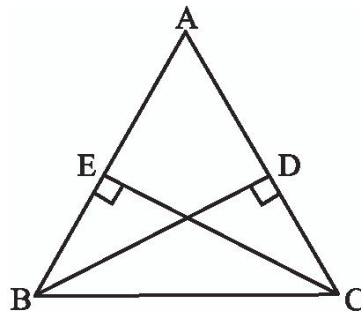
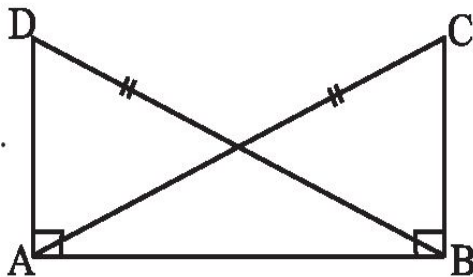

16. In the above sided Fig, BD and CE are altitudes of $\triangle ABC$ such that $BD = CE$.
 (i) State the three pairs of equal parts in $\triangle CBD$ and $\triangle BCE$.
 (ii) Is $\triangle CBD \cong \triangle BCE$? Why or why not?
 (iii) Is $\angle DCB = \angle ECB$? Why or why not?

17. ABC is an isosceles triangle with $AB = AC$ and AD is one of its altitudes.

- (i) State the three pairs of equal parts in $\triangle ADB$ and $\triangle ADC$.
- (ii) Is $\triangle ADB \cong \triangle ADC$? Why or why not?
- (iii) Is $\angle B = \angle C$? Why or why not?
- (iv) Is $BD = CD$? Why or why not?

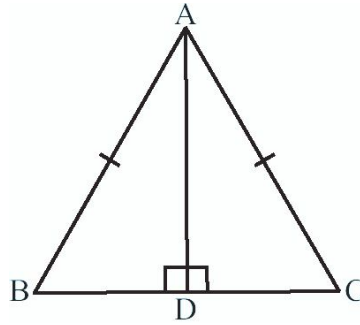

18. In $\triangle ABC$, $\angle A = 30^\circ$, $\angle B = 40^\circ$ and $\angle C = 110^\circ$ and in $\triangle PQR$, $\angle P = 30^\circ$, $\angle Q = 40^\circ$ and $\angle R = 110^\circ$. A student says that $\triangle ABC \cong \triangle PQR$ by AAA congruence criterion. Is he justified? Why or why not?

19. Complete the congruence statement:

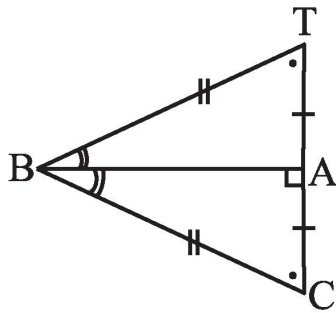

$\triangle BCA \cong ?$

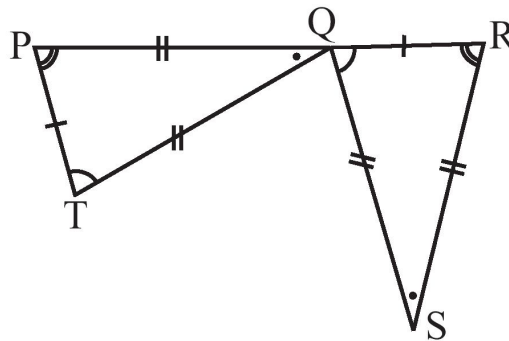

$\triangle QRS \cong ?$

20. If $\triangle ABC$ and $\triangle PQR$ are to be congruent, name one additional pair of corresponding parts. What criterion did you use?

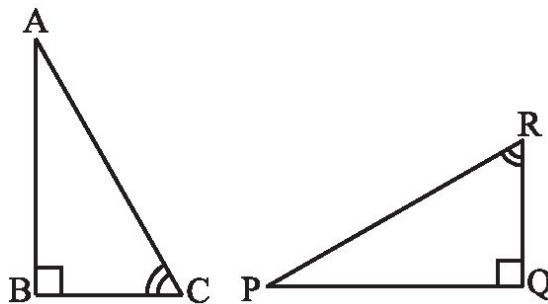

MCQ WORKSHEET-I
CLASS VII: CHAPTER - 8
COMPARING QUANTITIES

1. Find the ratio of 3 km to 300 m.
a) 10 : 1 b) 1 : 10 c) 1 : 5 d) none of these
2. A map is given with a scale of 2 cm = 1000 km. What is the actual distance between the two places in kms, if the distance in the map is 2.5 cm?
a) 1250 km b) 1500 km c) 2500 km d) none of these
3. 6 bowls cost Rs 90. What would be the cost of 10 such bowls?
a) Rs 300 b) Rs 150 c) Rs 200 d) Rs 250
4. The car that I own can go 150 km with 25 litres of petrol. How far can it go with 30 litres of petrol?
a) 125 km b) 150 km c) 250 km d) none of these
5. The ratio of 90 cm to 1.5 m is
a) 2 : 5 b) 3 : 5 c) 4 : 5 d) none of these
6. A picnic is being planned in a school for Class VII. Girls are 60% of the total number of students and are 18 in number. The ratio of the number of girls to the number of boys in the class is
a) 2 : 3 b) 3 : 2 c) 4 : 5 d) none of these
7. Find the ratio of Speed of a cycle 15 km per hour to the speed of scooter 30 km per hour.
a) 2 : 1 b) 1 : 2 c) 4 : 5 d) none of these
8. Find the ratio of 5 m to 10 km
a) 2000 : 1 b) 1 : 2000 c) 1 : 2 d) none of these
9. Find the ratio of 50 paise to Rs 5
a) 10 : 1 b) 1 : 10 c) 1 : 5 d) none of these
10. 72% of 25 students are good in hindi, how many are not good in hindi?
a) 16 b) 14 c) 18 d) 7
11. In a computer lab, there are 3 computers for every 6 students. How many computers will be needed for 24 students?
a) 12 b) 14 c) 16 d) none of these
12. Out of 32 students, 8 are absent. What percent of the students are present?
a) 75% b) 64% c) 60% d) none of these
13. There are 25 radios, 16 of them are out of order. What percent of radios are out of order?
a) 75% b) 64% c) 60% d) none of these
14. A shop has 500 parts, out of which 5 are defective. What percent are not defective?
a) 75% b) 99% c) 90% d) none of these
15. There are 120 voters, 90 of them voted yes. What percent voted yes?
a) 75% b) 99% c) 90% d) none of these

MCQ WORKSHEET-II
CLASS VII: CHAPTER - 8
COMPARING QUANTITIES

1. A survey of 40 children showed that 25% liked playing football. How many children not liked playing football?
a) 90 b) 60 c) 30 d) none of these
2. 8% children of a class of 25 like getting wet in the rain. How many children do not like getting wet in the rain.
a) 20 b) 22 c) 23 d) none of these
3. Rahul bought a sweater and saved Rs 20 when a discount of 25% was given. What was the price of the sweater before the discount?
a) Rs 30 b) Rs 40 c) Rs 60 d) Rs 80
4. Out of 15,000 voters in a constituency, 60% voted. Find the number of voters who did not vote.
a) 9000 b) 6000 c) 3000 d) none of these
5. Meeta saves Rs 400 from her salary. If this is 10% of her salary. What is her salary?
a) 4000 b) 6000 c) 3000 d) none of these
6. A local cricket team played 20 matches in one season. It won 25% of them. How many matches did they lose?
a) 12 b) 14 c) 16 d) none of these
7. A school team won 6 games this year against 4 games won last year. What is the per cent increase?
a) 75% b) 50% c) 60% d) none of these
8. The number of illiterate persons in a country decreased from 150 lakhs to 100 lakhs in 10 years. What is the percentage of decrease?
a) 30% b) 50% c) $33\frac{1}{3}\%$ d) none of these
9. Cost of an item is Rs 50. It was sold with a profit of 12%. Find the selling price.
a) Rs 56 b) Rs 60 c) Rs 70 d) none of these
10. **How much will an item cost if 10% discount is given on the marked price Rs 100**
a) 90 b) 110 c) 95 d) 85
11. A football team won 10 matches out of the total number of matches they played. If their win percentage was 40, then how many matches did they play in all?
a) 10 b) 25 c) 40 d) none of these
12. If Chameli had Rs 600 left after spending 75% of her money, how much did she have in the beginning?
a) Rs 3000 b) Rs 2400 c) Rs 2600 d) Rs 2800

MCQ WORKSHEET-III
CLASS VII: CHAPTER - 8
COMPARING QUANTITIES

1. The price of a scooter was Rs 34,000 last year. It has increased by 20% this year. What is the price now?
a) Rs 40800 b) Rs 32300 c) Rs 40000 d) none of these
2. The price of a scooter was Rs 34,000 last year. It has decreased by 5% this year. What is the price now?
a) Rs 40800 b) Rs 32300 c) Rs 40000 d) none of these
3. Mohit bought a CD for Rs. 750 and sold it Rs. 875. Find his gain or loss percent.
a) 5% b) 16% c) 6% d) $16\frac{2}{3}\%$
4. Rahul purchased a table for Rs. Rs. 1260 and due to some scratches on its top he had to sell it for Rs. 1197. Find his loss or gain percent.
a) 5% b) 4% c) 6% d) $16\frac{2}{3}\%$
5. Raghu bought an almirah for Rs. 6250 and spent Rs. 375 on its repairs. Then he sold it for Rs. Rs. 6890. Find his gain or loss percent.
a) 5% b) 4% c) 6% d) $16\frac{2}{3}\%$
6. A vendor bought oranges at Rs. 20 for Rs. 56 and sold them at Rs. 35 per dozen. Find his gain or loss percent.
a) 5% b) $4\frac{1}{6}\%$ c) 6% d) $16\frac{2}{3}\%$
7. The cost of a flower vase is Rs 120. If the shopkeeper sells it at a loss of 10%, find the price at which it is sold.
a) Rs 108 b) Rs 450 c) Rs 160 d) none of these
8. Selling price of a toy car is Rs 540. If the profit made by shopkeeper is 20%, what is the cost price of this toy?
a) Rs 108 b) Rs 450 c) Rs 160 d) none of these
9. The marked price of a ceiling fan is Rs. 1250 and the shopkeeper allows a discount of 6% on it. Find the selling price of the fan.
a) Rs 1180 b) Rs 1175 c) Rs 1160 d) none of these
10. A trader marks his goods at 40% above the cost price and allows a discount of 25%. What is his gain?
a) Rs 118 b) Rs 175 c) Rs 105 d) none of these
11. A dealer purchased a washing for Rs. 7660. He allows a discount of 12% on its marked price and still gains 10%. Find the marked price of the machine.
a) Rs 9800 b) Rs 9675 c) Rs 9575 d) none of these
12. On selling a fan for Rs. 810. Sunil gains 8%. For how much did he purchase it?
a) Rs 780 b) Rs 750 c) Rs 760 d) none of these

MCQ WORKSHEET-IV
CLASS VII: CHAPTER - 8
COMPARING QUANTITIES

1. On selling a table for Rs. 987. Ramesh loses 6%. For how much did he purchase it?
a) Rs 1500 b) Rs 105 c) Rs 1050 d) none of these
2. Rashmi buys a calculator for Rs. 720 and sells it at a loss of $6\frac{2}{3}\%$. For how much does she sell it?
a) Rs 700 b) Rs 650 c) Rs 672 d) none of these
3. The boys and girls in a school are in the ratio of 8 : 5. If the number of girls is 160, what is the total strength of the school?
a) 250 b) 260 c) 356 d) 416
4. The simple interest on Rs. 5000 for 219 days at 4% per annum is
a) Rs 126.50 b) Rs 120 c) Rs 125 d) Rs. 43.80
5. Find the simple interest on Rs. 2500 for 2 years 6 months at 6% per annum.
a) Rs 350 b) Rs 375 c) Rs 750 d) none of these
6. What sum will amount to Rs. 4590 at 12% per annum simple interest in 3 years?
a) Rs 3500 b) Rs 3375 c) Rs 3750 d) none of these
7. In what time will Rs. 1860 amount to Rs. 2278.50, if simple interest is calculated at 9% per annum?
a) 2 years b) $2\frac{1}{2}$ years c) 3 years d) 4 years
8. At what rate percent per annum will Rs. 1650 amount to Rs. 2046 in 3 years?
a) 8% b) 4% c) 6% d) $16\frac{2}{3}\%$
9. Simple interest on a certain sum is $\frac{16}{25}$ of the sum. Find the rate percent and the time if both are numerically equal.
a) 6 years b) $2\frac{1}{2}$ years c) 8 years d) 4 years
10. At what rate percent per annum simple interest will a sum treble itself in 16 years?
a) 12% b) 12.5% c) 15% d) $16\frac{2}{3}\%$
11. A sum of money at simple interest amounts to Rs. 696 in 2 years and Rs. 840 in 5 years. The sum is
a) Rs 500 b) Rs 600 c) Rs 560 d) Rs. 620

12. In what time will Rs. 1600 amount to Rs. 1768 at 6% per annum simple interest?
a) $1\frac{1}{4}$ years b) $2\frac{1}{2}$ years c) $1\frac{3}{4}$ years d) $1\frac{1}{2}$ years
13. A sum amounts to Rs. 3720 in 8 months at 5% per annum simple interest. The sum is
a) Rs 3500 b) Rs 3600 c) Rs 3560 d) Rs. 3620
14. At what rate percent per annum simple interest will a sum be double itself in 8 years?
a) 15% b) 14% c) 16% d) $12\frac{1}{2}$ %
15. At simple interest a sum becomes of itself in 5 years. The rate of interest percent per annum is
a) 8% b) 5% c) 10% d) 12%
-

PRACTICE QUESTIONS
CLASS VII: CHAPTER - 8
COMPARING QUANTITIES

1. Find the ratio of 3 km to 300 m.
2. A map is given with a scale of 2 cm = 1000 km. What is the actual distance between the two places in kms, if the distance in the map is 2.5 cm?
3. 6 bowls cost Rs 90. What would be the cost of 10 such bowls?
4. The car that I own can go 150 km with 25 litres of petrol. How far can it go with 30 litres of petrol?
5. In a computer lab, there are 3 computers for every 6 students. How many computers will be needed for 24 students?
6. Mala has a collection of bangles. She has 20 gold bangles and 10 silver bangles. What is the percentage of bangles of each type? Put it in the tabular form?
7. Out of 25 children in a class, 15 are girls. What is the percentage of girls?
8. Convert the given decimals to per cents: (a) 0.75 (b) 0.09 (c) 0.2
9. Out of 32 students, 8 are absent. What percent of the students are absent?
10. There are 25 radios, 16 of them are out of order. What percent of radios are out of order?
11. A shop has 500 parts, out of which 5 are defective. What percent are defective?
12. There are 120 voters, 90 of them voted yes. What percent voted yes?
13. If 65% of students in a class have a bicycle, what percent of the student do not have bicycles?
14. We have a basket full of apples, oranges and mangoes. If 50% are apples, 30% are oranges, then what percent are mangoes?
15. A survey of 40 children showed that 25% liked playing football. How many children liked playing football?
16. Find: (a) 50% of 164 (b) 75% of 12 (c) $12\frac{1}{2}$ % of 64
17. 8% children of a class of 25 like getting wet in the rain. How many children like getting wet in the rain.
18. Rahul bought a sweater and saved Rs 20 when a discount of 25% was given. What was the price of the sweater before the discount?
19. 9 is 25% of what number?
20. 75% of what number is 15?

21. Reena's mother said, to make *idlis*, you must take two parts rice and one part *urad dal*. What percentage of such a mixture would be rice and what percentage would be *urad dal*?
22. If Rs 250 is to be divided amongst Ravi, Raju and Roy, so that Ravi gets two parts, Raju three parts and Roy five parts. How much money will each get? What will it be in percentages?
23. Divide 15 sweets between Manu and Sonu so that they get 20 % and 80 % of them respectively.
24. If angles of a triangle are in the ratio 2 : 3 : 4. Find the value of each angle.
25. A school team won 6 games this year against 4 games won last year. What is the per cent increase?
26. The number of illiterate persons in a country decreased from 150 lakhs to 100 lakhs in 10 years. What is the percentage of decrease?
27. Find Percentage of increase or decrease: – Price of shirt decreased from Rs 80 to Rs 60. – Marks in a test increased from 20 to 30.
28. My mother says, in her childhood petrol was Re 1 a litre. It is Rs 52 per litre today. By what Percentage has the price gone up?
29. The cost of a flower vase is Rs 120. If the shopkeeper sells it at a loss of 10%, find the price at which it is sold.
30. Selling price of a toy car is Rs 540. If the profit made by shopkeeper is 20%, what is the cost price of this toy?
31. A shopkeeper bought a chair for Rs 375 and sold it for Rs 400. Find the gain Percentage.
32. Cost of an item is Rs 50. It was sold with a profit of 12%. Find the selling price.
33. An article was sold for Rs 250 with a profit of 5%. What was its cost price?
34. An item was sold for Rs 540 at a loss of 5%. What was its cost price?
35. Anita takes a loan of Rs 5,000 at 15% per year as rate of interest. Find the interest she has to pay at end of one year.
36. Rs 10,000 is invested at 5% interest rate p.a. Find the interest at the end of one year.
37. Rs 3,500 is given at 7% p.a. rate of interest. Find the interest which will be received at the end of two years.
38. Rs 6,050 is borrowed at 6.5% rate of interest p.a.. Find the interest and the amount to be paid at the end of 3 years.
39. Rs 7,000 is borrowed at 3.5% rate of interest p.a. borrowed for 2 years. Find the amount to be paid at the end of the second year.
40. If Manohar pays an interest of Rs 750 for 2 years on a sum of Rs 4,500, find the rate of interest.

41. You have Rs 2,400 in your account and the interest rate is 5%. After how many years would you earn Rs 240 as interest.
42. On a certain sum the interest paid after 3 years is Rs 450 at 5% rate of interest per annum. Find the sum.
43. In what time will Rs. 1860 amount to Rs. 2278.50, if simple interest is calculated at 9% per annum?
44. Simple interest on a certain sum is $\frac{16}{25}$ of the sum. Find the rate percent and the time if both are numerically equal.
45. In what time will Rs. 1600 amount to Rs. 1768 at 6% per annum simple interest?
46. At what rate percent per annum simple interest will a sum be double itself in 8 years?
47. At what rate percent per annum simple interest will a sum treble itself in 16 years?
48. A sum amounts to Rs. 3720 in 8 months at 5% per annum simple interest. Find the sum.
49. A sum of Rs 10,000 is borrowed at a rate of interest 15% per annum for 2 years. Find the simple interest on this sum and the amount to be paid at the end of 2 years.
50. A man got a 10% increase in his salary. If his new salary is Rs 1,54,000, find his original salary.
-

MCQ WORKSHEET-I
CLASS VII: CHAPTER - 9
RATIONAL NUMBERS

1. Associative property is not followed in _____.
(a) whole numbers (b) integers (c) natural numbers (d) rational numbers
2. _____ is the identity for the addition of rational numbers.
(a) 1 (b) 0 (c) -1 (d) $\frac{1}{2}$
3. _____ is the multiplicative identity for rational numbers.
(a) 1 (b) 0 (c) -1 (d) $\frac{1}{2}$
4. The additive inverse of $\frac{7}{5}$ is
(a) 1 (b) 0 (c) $-\frac{7}{5}$ (d) $\frac{7}{5}$
5. Zero has _____ reciprocal.
(a) 1 (b) 2 (c) 3 (d) no
6. The numbers _____ and _____ are their own reciprocals
(a) 1 and 0 (b) 1 and -1 (c) -1 and 0 (d) none of these.
7. The reciprocal of -5 is _____.
(a) 5 (b) 1 (c) $-\frac{1}{5}$ (d) $\frac{1}{5}$
8. Reciprocal of $\frac{1}{x}$, where $x \neq 0$ is _____.
(a) 1 (b) x (c) 0 (d) none of these
9. The product of two rational numbers is always a _____.
(a) whole numbers (b) integers (c) natural numbers (d) rational numbers
10. Simplify: $\frac{-4}{5} \times \frac{3}{7} \times \frac{15}{16} \times \left(\frac{-14}{9}\right)$
(a) 1 (b) 0 (c) 2 (d) $\frac{1}{2}$
11. The sum of the rational numbers $\frac{-5}{16}$ and $\frac{7}{12}$ is
(a) $\frac{-7}{48}$ (b) $\frac{-11}{30}$ (c) $\frac{13}{48}$ (d) $\frac{1}{3}$
12. What number should be added to $\frac{7}{12}$ to get $\frac{4}{15}$?
(a) $-\frac{19}{60}$ (b) $-\frac{11}{30}$ (c) $\frac{51}{60}$ (d) $\frac{1}{20}$

MCQ WORKSHEET-II
CLASS VII: CHAPTER - 9
RATIONAL NUMBERS

1. The reciprocal of a positive rational number is _____.
(a) negative (b) positive (c) zero (d) none of these

 2. What number should be subtracted from $-\frac{3}{5}$ to get -2 ?
(a) $-\frac{7}{5}$ (b) $-\frac{13}{5}$ (c) $\frac{13}{5}$ (d) $\frac{7}{5}$

 3. Which of the rational numbers $\frac{-11}{28}$, $\frac{-5}{7}$, $\frac{9}{-14}$, $\frac{29}{-42}$ is the greatest?
(a) $\frac{-11}{28}$ (b) $\frac{-5}{7}$ (c) $\frac{9}{-14}$ (d) $\frac{29}{-42}$

 4. Which of the rational numbers $\frac{-5}{16}$, $\frac{-13}{24}$, $\frac{3}{-4}$, $\frac{7}{-12}$ is the smallest?
(a) $\frac{-5}{16}$ (b) $\frac{-13}{24}$ (c) $\frac{3}{-4}$ (d) $\frac{7}{-12}$

 5. Simplify: $\frac{2}{3} + \frac{-4}{5} + \frac{7}{15} + \frac{-11}{20}$
(a) $\frac{-1}{5}$ (b) $\frac{-13}{60}$ (c) $\frac{-4}{15}$ (d) $\frac{-7}{30}$

 6. Rational number $\frac{3}{40}$ is equal to:
(a) 0.75 (b) 0.12 (c) 0.012 (d) 0.075

 7. A rational number between 3 and 4 is:
(a) $\frac{3}{2}$ (b) $\frac{4}{3}$ (c) $\frac{7}{2}$ (d) $\frac{7}{4}$

 8. A rational number between $\frac{3}{5}$ and $\frac{4}{5}$ is:
(a) $\frac{7}{5}$ (b) $\frac{7}{10}$ (c) $\frac{3}{10}$ (d) $\frac{4}{10}$

 9. A rational number between $\frac{1}{2}$ and $\frac{3}{4}$ is:
(a) $\frac{2}{5}$ (b) $\frac{5}{8}$ (c) $\frac{4}{3}$ (d) $\frac{1}{4}$

 10. The multiplicative inverse of $\frac{3}{40}$ is:
(a) 1 (b) 0 (c) any number (d) none of these
-

MCQ WORKSHEET-III
CLASS VII: CHAPTER - 9
RATIONAL NUMBERS

1. Find x such that $\frac{-1}{5} = \frac{8}{x}$
(a) -5 (b) -40 (c) any number (d) none of these
2. Find x such that $\frac{7}{-3} = \frac{x}{6}$
(a) -14 (b) -3 (c) -21 (d) none of these
3. Find x such that $\frac{3}{5} = \frac{x}{-25}$
(a) -5 (b) -15 (c) -15 (d) none of these
4. Find x such that $\frac{13}{6} = \frac{-65}{x}$
(a) -30 (b) 30 (c) -6 (d) none of these
5. Find x such that $\frac{16}{x} = -4$
(a) 4 (b) -4 (c) 2 (d) none of these
6. Find x such that $\frac{-48}{x} = 2$
(a) 24 (b) -12 (c) -24 (d) none of these
7. Find x such that $\frac{-3}{8}$ and $\frac{x}{-24}$ are equivalent rational numbers.
(a) 3 (b) 9 (c) 8 (d) none of these
8. Find the value of $\frac{9}{2} \times \frac{-4}{3}$
(a) 6 (b) -6 (c) 1 (d) none of these
9. Find the value of $\frac{3}{-5} \times \frac{-5}{-3}$
(a) -1 (b) 0 (c) 1 (d) none of these
10. Find the value of $\frac{3}{10} \times \frac{-2}{3}$
(a) 5 (b) $\frac{1}{5}$ (c) $\frac{-1}{5}$ (d) none of these
11. Find the value of $(-6) \div \frac{2}{3}$
(a) -9 (b) 9 (c) -4 (d) none of these

12. Find the value of $\frac{-1}{8} \div \frac{3}{4}$

- (a) $\frac{-1}{6}$ (b) $\frac{1}{6}$ (c) $\frac{-3}{32}$ (d) none of these

The points P, Q, R, S, T, U and V on the number line are such that, $US = SV = VR$, and $WT = TP = PQ$. Answer the following question from Q13 – Q20.

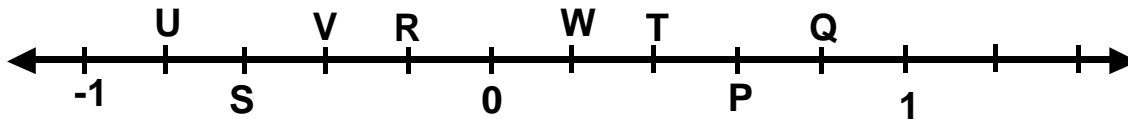

13. The rational number represented by P

- (a) $\frac{3}{5}$ (b) $\frac{2}{5}$ (c) $\frac{4}{5}$ (d) none of these

14. The rational number represented by Q

- (a) $\frac{3}{5}$ (b) $\frac{2}{5}$ (c) $\frac{4}{5}$ (d) none of these

15. The rational number represented by R

- (a) $\frac{-3}{5}$ (b) $\frac{-2}{5}$ (c) $\frac{-4}{5}$ (d) none of these

16. The rational number represented by S

- (a) $\frac{-3}{5}$ (b) $\frac{-2}{5}$ (c) $\frac{-4}{5}$ (d) none of these

17. The rational number represented by T

- (a) $\frac{3}{5}$ (b) $\frac{2}{5}$ (c) $\frac{4}{5}$ (d) none of these

18. The rational number represented by U

- (a) $\frac{-3}{5}$ (b) $\frac{-2}{5}$ (c) $\frac{-4}{5}$ (d) none of these

19. The rational number represented by V

- (a) $\frac{-3}{5}$ (b) $\frac{-2}{5}$ (c) $\frac{-4}{5}$ (d) none of these

20. The rational number represented by W

- (a) $\frac{3}{5}$ (b) $\frac{2}{5}$ (c) $\frac{4}{5}$ (d) none of these

MCQ WORKSHEET-IV
CLASS VII: CHAPTER - 9
RATIONAL NUMBERS

1. The equivalent rational number of $\frac{-6}{5}$ is
(a) $\frac{-3}{5}$ (b) $\frac{12}{10}$ (c) $\frac{-12}{10}$ (d) none of these
2. Fill in the boxes with the correct symbol: $\frac{-5}{7} \boxed{\dots} \frac{2}{3}$
(a) $>$ (b) $<$ (c) $=$ (d) none of these
3. Fill in the boxes with the correct symbol: $\frac{-4}{5} \boxed{\dots} \frac{-5}{7}$
(a) $>$ (b) $<$ (c) $=$ (d) none of these
4. Fill in the boxes with the correct symbol: $\frac{-7}{8} \boxed{\dots} \frac{14}{-16}$
(a) $>$ (b) $<$ (c) $=$ (d) none of these
5. Fill in the boxes with the correct symbol: $\frac{5}{-11} \boxed{\dots} \frac{-5}{11}$
(a) $>$ (b) $<$ (c) $=$ (d) none of these
6. Fill in the boxes with the correct symbol: $\frac{1}{-3} \boxed{\dots} \frac{-1}{4}$
(a) $>$ (b) $<$ (c) $=$ (d) none of these
7. Rewrite the rational number $\frac{-18}{48}$ in the simplest form.
(a) $\frac{-9}{24}$ (b) $\frac{-3}{8}$ (c) $\frac{3}{8}$ (d) none of these
8. Rewrite the rational number $\frac{24}{-72}$ in the simplest form.
(a) $\frac{12}{-36}$ (b) $\frac{6}{-18}$ (c) $\frac{1}{-3}$ (d) none of these
9. Rewrite the rational number $\frac{44}{-72}$ in the simplest form.
(a) $\frac{22}{-36}$ (b) $\frac{11}{-18}$ (c) $\frac{11}{18}$ (d) none of these
10. Write the next rational number in the pattern: $\frac{-3}{5}, \frac{-6}{10}, \frac{-9}{15}, \frac{-12}{20}, \dots$
(a) $\frac{12}{25}$ (b) $\frac{15}{25}$ (c) $\frac{-15}{25}$ (d) none of these

11. Write the next rational number in the pattern: $\frac{-1}{4}, \frac{-2}{8}, \frac{-3}{12}, \dots$

- (a) $\frac{-4}{15}$ (b) $\frac{-4}{16}$ (c) $\frac{-4}{20}$ (d) none of these

12. Write the next rational number in the pattern: $\frac{-1}{6}, \frac{2}{-12}, \frac{3}{-18}, \frac{4}{-24}, \dots$

- (a) $\frac{-5}{-30}$ (b) $\frac{5}{-30}$ (c) $\frac{4}{-30}$ (d) none of these

13. Write the next rational number in the pattern: $\frac{-1}{7}, \frac{2}{-14}, \frac{3}{-21}, \frac{4}{-28}, \dots$

- (a) $\frac{-5}{-35}$ (b) $\frac{5}{-35}$ (c) $\frac{4}{-35}$ (d) none of these

14. Write the next rational number in the pattern: $-1, \frac{-1}{2}, \frac{-1}{4}, \frac{-1}{6}, \dots$

- (a) $\frac{-1}{-8}$ (b) $\frac{1}{-8}$ (c) $\frac{-1}{8}$ (d) none of these

15. Rewrite the rational number $\frac{-36}{24}$ in the simplest form.

- (a) $\frac{-18}{12}$ (b) $\frac{-9}{6}$ (c) $\frac{-3}{2}$ (d) none of these

.....

PRACTICE QUESTIONS
CLASS VII: CHAPTER - 9
RATIONAL NUMBERS

1. Fill in the boxes:

$$(i) \frac{5}{4} = \frac{\square}{16} = \frac{25}{\square} = \frac{-15}{\square}$$

$$(ii) \frac{-3}{7} = \frac{\square}{14} = \frac{9}{\square} = \frac{-6}{\square}$$

2. Reduce to the standard form: (i) $\frac{-45}{30}$ (ii) $\frac{36}{-24}$ (iii) $\frac{-3}{-15}$ (iv) $\frac{-18}{45}$ (v) $\frac{-12}{18}$

3. Find five rational numbers between $\frac{-5}{7}$ and $\frac{-3}{8}$.

4. List three rational numbers between -2 and -1 .

5. Write four more numbers in the following pattern: $\frac{-1}{3}, \frac{-2}{6}, \frac{-3}{9}, \frac{-4}{12}, \dots$

6. Which is greater in each of the following:

$$(i) \frac{2}{3}, \frac{5}{2} \quad (ii) \frac{-5}{6}, \frac{-4}{3} \quad (iii) \frac{-3}{4}, \frac{2}{-3}$$

$$(iv) \frac{-1}{4}, \frac{1}{4} \quad \text{and} \quad (v) -3\frac{2}{7}, -3\frac{4}{5}$$

7. Write the following rational numbers in ascending order:

$$(i) \frac{-3}{5}, \frac{-2}{5}, \frac{-1}{5} \quad (ii) \frac{-1}{3}, \frac{-2}{9}, \frac{-4}{3} \quad (iii) \frac{-3}{7}, \frac{-3}{2}, \frac{-3}{4}$$

8. Write the following rational numbers in descending order: $\frac{-1}{3}, \frac{-2}{9}, \frac{-4}{3}$

9. The points P, Q, R, S, T, U, A and B on the number line are such that, $TR = RS = SU$ and $AP = PQ = QB$. Name the rational numbers represented by P, Q, R and S.

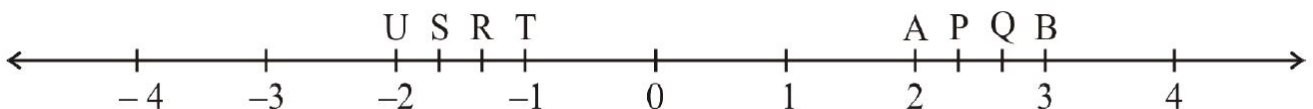

10. Give four rational numbers equivalent to:

$$(i) \frac{-2}{7} \quad (ii) \frac{5}{-3} \quad (iii) \frac{4}{9}$$

11. Draw the number line and represent the following rational numbers on it:

(i) $\frac{3}{4}$ (ii) $\frac{-5}{8}$ (iii) $\frac{-7}{4}$ (iv) $\frac{7}{8}$

12. What will be the additive inverse of $\frac{-3}{9}$, $\frac{-9}{11}$, $\frac{5}{7}$?

13. Satpal walks $\frac{2}{3}$ km from a place P, towards east and then from there $1\frac{5}{7}$ km towards west. Where will he be now from P?

14. Find: (i) $\frac{7}{9} - \frac{2}{5}$ (ii) $2\frac{1}{5} - \frac{(-1)}{3}$

15. Find: (i) $\frac{2}{3} \times \frac{-7}{8}$ (ii) $\frac{-6}{7} \times \frac{5}{7}$

16. What will be the reciprocal of $\frac{-6}{11}$ and $\frac{-8}{5}$?

17. Find the sum:

(i) $\frac{5}{4} + \left(\frac{-11}{4}\right)$ (ii) $\frac{-8}{19} + \frac{(-2)}{57}$ (iii) $-2\frac{1}{3} + 4\frac{3}{5}$ (iv) $\frac{-9}{10} + \frac{22}{15}$

18. Find:

(i) $\frac{7}{24} - \frac{17}{36}$ (ii) $\frac{5}{63} - \left(\frac{-6}{21}\right)$ (iii) $\frac{-6}{13} - \left(\frac{-7}{15}\right)$

19. Find the product:

(i) $\frac{9}{2} \times \left(\frac{-7}{4}\right)$ (ii) $\frac{-6}{15} \times \frac{9}{11}$ (iii) $\frac{3}{7} \times \left(\frac{-2}{5}\right)$

20. Find the value of:

(i) $\frac{-3}{5} \div 2$ (ii) $\frac{-4}{5} \div (-3)$ (iii) $\frac{-1}{8} \div \frac{3}{4}$ (iv) $\frac{-2}{13} \div \frac{1}{7}$ (v) $\frac{-7}{12} \div \left(\frac{-2}{13}\right)$

21. Find $\frac{3}{7} + \left(\frac{-6}{11}\right) + \left(\frac{-8}{21}\right) + \frac{5}{22}$

22. Find $\frac{-4}{5} \times \frac{3}{7} \times \frac{15}{16} \times \left(\frac{-14}{9}\right)$

23. Find using distributive property: (i) $\left\{\frac{7}{5} \times \left(\frac{-3}{12}\right)\right\} + \left\{\frac{7}{5} \times \frac{5}{12}\right\}$ (ii) $\left\{\frac{9}{16} \times \frac{4}{12}\right\} + \left\{\frac{9}{16} \times \frac{-3}{9}\right\}$

24. Find $\frac{2}{5} \times \frac{-3}{7} - \frac{1}{14} - \frac{3}{7} \times \frac{3}{5}$

25. Simplify: $\frac{-4}{5} \times \frac{3}{7} \times \frac{15}{16} \times \left(\frac{-14}{9}\right)$
26. Multiply $\frac{6}{13}$ by the reciprocal of $\frac{-7}{16}$.
27. What number should be added to $\frac{7}{12}$ to get $\frac{4}{15}$?
28. What number should be subtracted from $-\frac{3}{5}$ to get -2 ?
29. Write any 3 rational numbers between -2 and 0 .
30. Find any ten rational numbers between $-\frac{5}{6}$ and $\frac{5}{8}$
31. Find three rational numbers between $\frac{1}{4}$ and $\frac{1}{2}$
32. Find ten rational numbers between $\frac{1}{4}$ and $\frac{1}{2}$
33. Represent these numbers on the number line. (i) $\frac{7}{4}$ (ii) $-\frac{5}{6}$ (iii) $\frac{4}{7}$ (iv) $\frac{9}{4}$
34. Represent $\frac{-2}{11}, \frac{-5}{11}, \frac{-9}{11}$ on the number line
35. Find five rational numbers between (i) $\frac{2}{3}$ and $\frac{4}{5}$ (ii) $-\frac{3}{2}$ and $\frac{5}{3}$
36. Find five rational numbers between $\frac{1}{4}$ and $\frac{1}{2}$
37. Write five rational numbers greater than -2
38. Find ten rational numbers between $\frac{3}{5}$ and $\frac{3}{4}$.
39. Write.
- (i) The rational number that does not have a reciprocal.
 - (ii) The rational numbers that are equal to their reciprocals.
 - (iii) The rational number that is equal to its negative.
40. Write five rational numbers which are smaller than 2 .
-

PRACTICE QUESTIONS
CLASS – VII: CHAPTER – 10
PRACTICAL GEOMETRY

1. Draw a line AB and take a point P outside it. Draw a line CD parallel to AB and passing through the point P.
2. Draw a line AB and draw another line CD parallel to AB at a distance of 3.5 cm from it.
3. Draw a line 'l' and draw another line 'm' parallel to 'l' at a distance of 4.3 cm from it.
4. Construct a triangle ABC, given that AB = 5 cm, BC = 6 cm and AC = 7 cm.
5. Construct a triangle DEF such that DE = 5 cm, EF = 6 cm, and DF = 7 cm.
6. Draw ΔPQR with PQ = 4 cm, QR = 3.5 cm and PR = 4 cm. What type of triangle is this?
7. Construct ΔABC such that AB = 2.5 cm, BC = 6 cm and AC = 6.5 cm. Measure $\angle B$.
8. Construct a triangle PQR, given that PQ = 3 cm, QR = 5.5 cm and $\angle PQR = 60^\circ$.
9. Construct an isosceles triangle in which the lengths of each of its equal sides is 6.5 cm and the angle between them is 110° .
10. Construct ΔXYZ if it is given that XY = 6 cm, $m\angle ZXY = 30^\circ$ and $m\angle XYZ = 100^\circ$.
11. Examine whether you can construct $\otimes DEF$ such that EF = 7.2 cm, $m\angle E = 110^\circ$ and $m\angle F = 80^\circ$. Justify your answer.
12. Construct ΔLMN , right-angled at M, given that LN = 5 cm and MN = 3 cm.
13. Construct a right-angled triangle whose hypotenuse is 6 cm long and one of the legs is 4 cm long.
14. Construct an isosceles right-angled triangle ABC, where $m\angle ACB = 90^\circ$ and AC = 6 cm.
15. Construct a triangle ABC in which AB = 5 cm, AC = 4.3 cm and $\angle A = 60^\circ$. Also draw the perpendicular bisector of BC.
16. Construct a triangle PQR in which QR = 4.2 cm, $\angle Q = 120^\circ$ and PQ = 3.5 cm. Draw $PM \perp QR$.
17. Construct a triangle ABC in which AB = AC = 4.8 cm and BC = 5.3 cm. Measure $\angle B$ and $\angle C$. Draw $AD \perp BC$.
18. Construct a triangle PQR in which QR = 6 cm, PQ = 4.4 cm and PR = 5.3 cm. Draw the bisector of $\angle P$.
19. Construct an equilateral triangle each of whose sides measures 6.2 cm. Measure each one of its angle.
20. Construct a right-angled triangle whose hypotenuse measure 5.6 cm and one of whose acute angles measures 30° .

MCQ WORKSHEET-I
CLASS VII: CHAPTER - 11
PERIMETER AND AREA

1. The area of a rectangular sheet is 500 cm^2 . If the length of the sheet is 25 cm, what is its width?
(a) 20 cm (b) 17 cm (c) 30 cm (d) 25 cm
 2. If the area of rectangle increases from 2 cm^2 to 4 cm^2 the perimeter will
(a) increase (b) decrease (c) remains same (d) none of these
 3. The area of a square whose perimeter is 4 m
(a) 1 m^2 (b) 4 m^2 (c) 2 m^2 (d) 3 m^2
 4. Which figure encloses more area : a square of side 2 cm ; a rectangle of side 3 cm & 2 cm ; An equilateral triangle of side 4 cm
(a) rectangle (b) square (c) triangle (d) same of rectangle & square
 5. The area of rectangle whose length is 15 cm & breadth is 6 m
(a) 9000 cm^2 (b) 90 cm^2 (c) 9 cm^2 (d) 900 cm^2
 6. $\triangle ABC$ is isosceles in which $AE \perp BC$, $AE = 6 \text{ cm}$, $BC = 9 \text{ cm}$, the area of $\triangle ABC$ is
(a) 27 cm^2 (b) 54 cm^2 (c) 22.5 cm^2 (d) 45 cm^2
 7. The area of parallelogram is
(a) base + height (b) base x height (c) base x base (d) height x height
 8. The base in the area of parallelogram is
(a) $\frac{\text{area}}{\text{height}}$ (b) $\frac{\text{height}}{\text{area}}$ (c) area x base (d) area x height
 9. The height in the area of parallelogram is
(a) $\frac{\text{area}}{\text{base}}$ (b) $\frac{\text{base}}{\text{area}}$ (c) area x base (d) area x height
 10. Which of the following has the formula : Base x Height
(a) area of parallelogram (b) area of quadrilateral
(c) area of triangle (d) area of trapezium
 11. The area of triangle is
(a) base x height (b) $\frac{1}{2}$ x base x height (c) $\frac{1}{2}$ x (base + height) (d) base + height
 12. The height in the area of a triangle
(a) $\frac{2.\text{area}}{\text{base}}$ (b) $\frac{2.\text{base}}{\text{area}}$ (c) $\frac{\text{base}}{2.\text{area}}$ (d) $\frac{\text{area}}{2.\text{base}}$
-

MCQ WORKSHEET-II
CLASS VII: CHAPTER - 11
PERIMETER AND AREA

1. If the area of the triangle is 36 cm^2 and the height is 3 cm, the base of the triangle will be
(a) 12 cm (b) 39 cm (c) 108 cm (d) 24 cm
2. The base in the area of triangle is
(a) $\frac{2 \cdot \text{area}}{\text{height}}$ (b) $\frac{2 \cdot \text{height}}{\text{area}}$ (c) $\frac{\text{height}}{2 \cdot \text{area}}$ (d) $\frac{\text{area}}{2 \cdot \text{height}}$
3. The distance around a circular region is known as its
(a) area (b) diameter of circle (c) circumference (d) radius
4. The perimeter of square of side 2.5 m is
(a) 10.2 m (b) 10.2 m^2 (c) 6.25 m^2 (d) 6.25 m
5. The perimeter of rectangle of length 1.5 cm & breadth 2 cm is
(a) 3.4 cm (b) 7 cm (c) 6 cm (d) 3.5 cm
6. The area of parallelogram whose base 6 cm & altitude 7 cm is
(a) 18 cm^2 (b) 18 cm (c) 9 cm^2 (d) 9 cm
7. The height of parallelogram whose area is 35 cm^2 and altitude 7 cm
(a) 5 cm (b) 5 cm^2 (c) 245 cm (d) 245 cm^2
8. Area of triangle whose base is 15 cm and corresponding altitude is 6 cm will be
(a) 45 cm^2 (b) 90 cm^2 (c) 45 cm (d) 90 cm
9. Find the area of a right triangle whose base is 3 cm, perpendicular is 2 cm and hypotenuse is 5 cm.
(a) 3 cm^2 (b) 7.5 cm^2 (c) 5 cm^2 (d) 6 cm
10. What will be the area of circular button of radius 7 cm
(a) 154 cm^2 (b) 49 cm^2 (c) 154 cm (d) $3.14 \times 7 \text{ cm}^2$
11. The circumference of circle whose diameter is 14 cm will be
(a) 44 cm (b) 88 cm (c) 44 cm^2 (d) 88 cm^2
12. The perimeter of circle is its
(a) area (b) circumference (c) radius (d) diameter
13. Diameter is _____ .
(a) twice radius (b) half radius (c) equal to radius (d) one-third of radius
14. π (pi) is
(a) ratio of circumference to diameter (b) $21/17$
(c) diameter to circumference (d) 3.41
15. If the area of circle is 44 cm^2 , the area of shaded portion will be
(a) 11 cm^2 (b) 11 cm
(c) 22 cm^2 (d) 22 cm^2

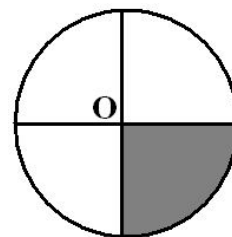

MCQ WORKSHEET-III
CLASS VII: CHAPTER - 11
PERIMETER AND AREA

1. If the radius of pipe is 1 cm , the circumference of pipe will be
(a) 62.8 cm (b) 6.28 cm (c) 62.8 cm² (d) 6.28 cm
2. The circumference of a circle is
(a) πr (b) πr^2 (c) $\pi \times 2r$ (d) $\pi + 2r$
3. The diameter of a circle is
(a) r^2 (b) $2r$ (c) $2\pi r^3$ (d) πr^2
4. Which of the following is an example of circle?
(a) a chair (b) a bottle cap (c) a cup (d) a table
5. The area of a circle is
(a) $2 \pi r$ (b) $2\pi r^2$ (c) πr^2 (d) πd
6. $1 \text{ m}^2 = \underline{\hspace{2cm}}$.
(a) 100 cm^2 (b) 1000 cm^2 (c) 10000 m^2 (d) 10000 cm^2
7. One hectare is equal to
(a) 100 m^2 (b) 1000 m^2 (c) $10,000 \text{ m}^2$ (d) $10,000 \text{ m}$
8. The circumference of a circle with radius 7 cm is
(a) 11 cm (b) 22 cm (c) 44 cm (d) 49 cm
9. The value of constant π is
(a) 31.4 (b) $\frac{22}{7}$ (c) $\frac{7}{22}$ (d) 314
10. The area of a circle is $49\pi \text{ cm}^2$. Its circumference is
(a) $7\pi \text{ cm}$ (b) $14\pi \text{ cm}$ (c) $21\pi \text{ cm}$ (d) $28\pi \text{ cm}$
11. The perimeter of circular field is 242cm. The area of the field is
(a) 9317 cm^2 (b) 18634 cm^2 (c) 4658.5 cm^2 (d) none of these
12. The area of a circle is 38.5 cm^2 . Its circumference is
(a) 62 cm (b) 12.1 cm (c) 11 cm (d) 22 cm
13. The difference between the circumference and radius of a circle is 37 cm. The area of the circle is
(a) 111 cm^2 (b) 184 cm^2 (c) 154 cm^2 (d) 259 cm^2
14. The circumference of two circles are in the ratio 2 : 3. The ratio of their areas is
(a) 2 : 3 (b) 4 : 9 (c) 9 : 4 (d) none of these
15. On increasing the diameter of circle by 40%, its area will be increased by
(a) 40% (b) 80% (c) 96% (d) none of these

MCQ WORKSHEET-IV
CLASS VII: CHAPTER - 11
PERIMETER AND AREA

1. On decreasing the radius of the circle by 30%, its area is decreased by
(a) 30% (b) 60% (c) 45% (d) none of these
2. The area of the square is the same as the area of the circle. Their perimeter re in the ratio
(a) 1 : 1 (b) π : 2 (c) 2 : π (d) none of these
3. The areas of the two circle are in the ratio 4 : 9. The ratio of their circumference is
(a) 2 : 3 (b) 4 : 9 (c) 9 : 4 (d) 4 : 9
4. In making 1000 revolutions, a wheel covers 88 km. The diameter of the wheel is
(a) 14 m (b) 24 m (c) 28 m (d) 40 m
5. The diameter of a wheel is 40 cm. How many revolutions will it make an covering 176 m?
(a) 140 (b) 150 (c) 160 (d) 166
6. The radius of wheel is 0.25 m. How many revolutions will it make in covering 11 km?
(a) 2800 (b) 4000 (c) 5500 (d) 7000
7. Find the circumference of a circle of diameter 21 cm.
(a) 62 cm (b) 64 cm (c) 66 cm (d) 68 cm
8. Find the area of a circle whose circumference is 52.8 cm.
(a) 221.76 cm^2 (b) 220.76 cm^2 (c) 200.76 cm^2 (d) none of these.
9. A steel wire when bent in the form of a square, encloses an area of 121 sq. cm. The same wire is bent in the form of a circle. Find the area of the circle.
(a) 111 cm^2 (b) 184 cm^2 (c) 154 cm^2 (d) 259 cm^2
10. If the perimeter of a semicircular protractor is 36 cm, find the diameter.
(a) 14 cm (b) 16 cm (c) 18 cm (d) 12 cm
11. A bicycle wheel makes 5000 revolutions in moving 11 km. Find the diameter of the wheel.
(a) 60 cm (b) 70 cm (c) 66 cm (d) 68 cm
12. The diameter of the wheels of a bus is 140 cm. How many revolutions per minute must a wheel make in order to move a t a speed of 66km/hr?
(a) 240 (b) 250 (c) 260 (d) 270
13. The perimeter of regular polygon is
(a) no. of sides \times lengths of one side (b) no. of sides + lengths of one side
(c) no. of sides – lengths of one side (d) no. of sides \div lengths of one side
14. A wire is in the shape of a square of side 10 cm. If the wire is rebent into a rectangle of length 12 cm, find its breadth.
(a) 12 cm (b) 7 cm (c) 8 cm (d) 9 cm

15. A paper is in the form of a rectangle ABCD in which AB = 18cm and BC = 14cm. A semicircular portion with BC as diameter is cut off. Find the area of the remaining paper (see in below figure).

- (a) 175 cm^2 (b) 165 cm^2 (c) 145 cm^2 (d) none of these

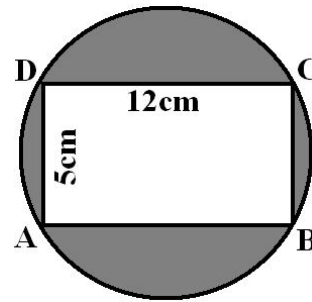
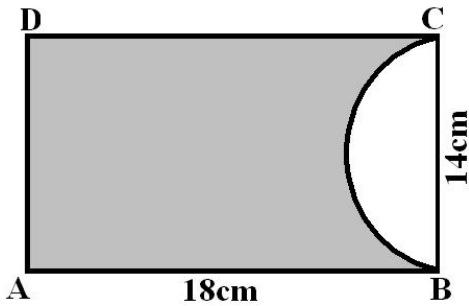

16. Find the area of the shaded region in the above sided figure. Take $\pi = 3.14$

- (a) 75 cm^2 (b) 72 cm^2 (c) 70 cm^2 (d) none of these

17. The perimeter of parallelogram PQRS is:

- (a) 12 cm (b) 7 cm (c) 38 cm (d) 19 cm

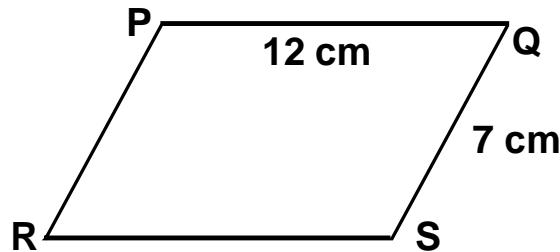

18. The area of a square and a rectangle are equal. If the side of the square is 40 cm and the breadth of the rectangle is 25 cm, find the length of the rectangle.

- (a) 60 cm (b) 62 cm (c) 64 cm (d) 68 cm

PRACTICE QUESTIONS
CLASS VII: CHAPTER - 11
PERIMETER AND AREA

1. A door-frame of dimensions $3\text{ m} \times 2\text{ m}$ is fixed on the wall of dimension $10\text{ m} \times 10\text{ m}$. Find the total labour charges for painting the wall if the labour charges for painting 1 m^2 of the wall is Rs 2.50.
2. The area of a rectangular sheet is 500 cm^2 . If the length of the sheet is 25 cm , what is its width? Also find the perimeter of the rectangular sheet.
3. Anu wants to fence the garden in front of her house, on three sides with lengths 20 m , 12 m and 12 m . Find the cost of fencing at the rate of Rs 150 per metre.
4. A wire is in the shape of a square of side 10 cm . If the wire is rebent into a rectangle of length 12 cm , find its breadth. Which encloses more area, the square or the rectangle?
5. The area of a square and a rectangle are equal. If the side of the square is 40 cm and the breadth of the rectangle is 25 cm , find the length of the rectangle. Also, find the perimeter of the rectangle.
6. In a parallelogram ABCD, $AB = 7.2\text{ cm}$ and the perpendicular from C on AB is 4.5 cm .
7. Find the area of following parallelograms:

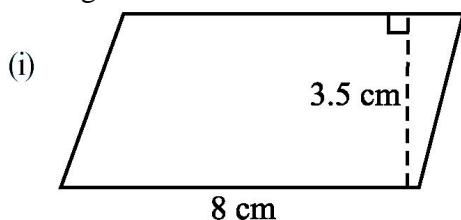

8. One of the sides and the corresponding height of a parallelogram are 4 cm and 3 cm respectively. Find the area of the parallelogram.
9. Find the height ' x ' if the area of the parallelogram is 24 cm^2 and the base is 4 cm .

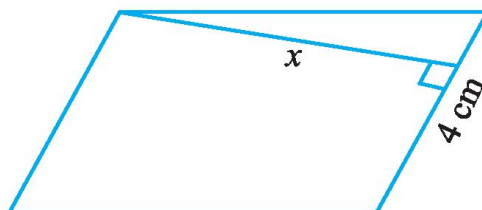

10. The two sides of the parallelogram ABCD are 6 cm and 4 cm . The height corresponding to the base CD is 3 cm . Find the (i) area of the parallelogram. (ii) the height corresponding to the base AD.
11. Find BC, if the area of the triangle ABC is 36 cm^2 and the height AD is 3 cm .
12. What is the circumference of a circle of diameter 10 cm (Take $\pi = 3.14$)?
13. What is the circumference of a circular disc of radius 14 cm ?

14. Find the area of the following triangles.

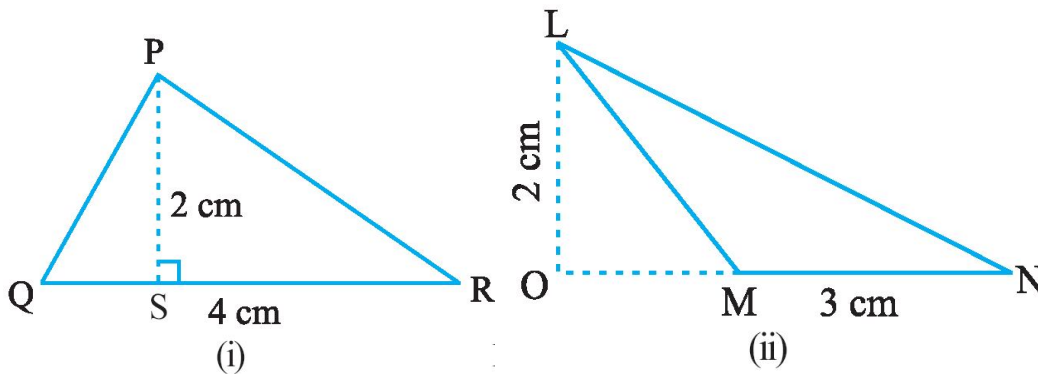

15. The radius of a circular pipe is 10 cm. What length of a tape is required to wrap once around the pipe ($\pi = 3.14$)?

16. Find the area of a circle of radius 30 cm (use $\pi = 3.14$).

17. Diameter of a circular garden is 9.8 m. Find its area.

18. Shazli took a wire of length 44 cm and bent it into the shape of a circle. Find the radius of that circle. Also find its area. If the same wire is bent into the shape of a square, what will be the length of each of its sides? Which figure encloses more area, the circle or the square?

19. From a circular card sheet of radius 14 cm, two circles of radius 3.5 cm and a rectangle of length 3 cm and breadth 1 cm are removed. (as shown in the adjoining figure). Find the area of the remaining sheet.

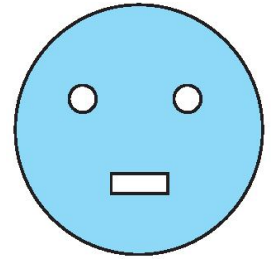

20. The circumference of a circle is 31.4 cm. Find the radius and the area of the circle? (Take $\pi = 3.14$)

21. A circular flower bed is surrounded by a path 4 m wide. The diameter of the flower bed is 66 m. What is the area of this path? ($\pi = 3.14$)

22. How many times a wheel of radius 28 cm must rotate to go 352 m?

23. The minute hand of a circular clock is 15 cm long. How far does the tip of the minute hand move in 1 hour. (Take $\pi = 3.14$)

24. A rectangular park is 45 m long and 30 m wide. A path 2.5 m wide is constructed outside the park. Find the area of the path.

25. A path 5 m wide runs along inside a square park of side 100 m. Find the area of the path. Also find the cost of cementing it at the rate of Rs 250 per m^2 .

26. Two cross roads, each of width 5 m, run at right angles through the centre of a rectangular park of length 70 m and breadth 45 m and parallel to its sides. Find the area of the roads. Also find the cost of constructing the roads at the rate of Rs 105 per m^2 .

27. Two cross roads, each of width 10 m, cut at right angles through the centre of a rectangular park of length 700 m and breadth 300 m and parallel to its sides. Find the area of the roads. Also find the area of the park excluding cross roads. Give the answer in hectares.

28. In the following figures, find the area of the shaded portions:

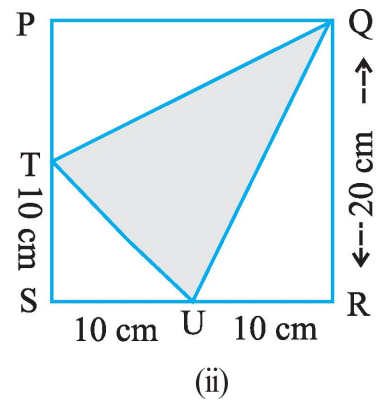
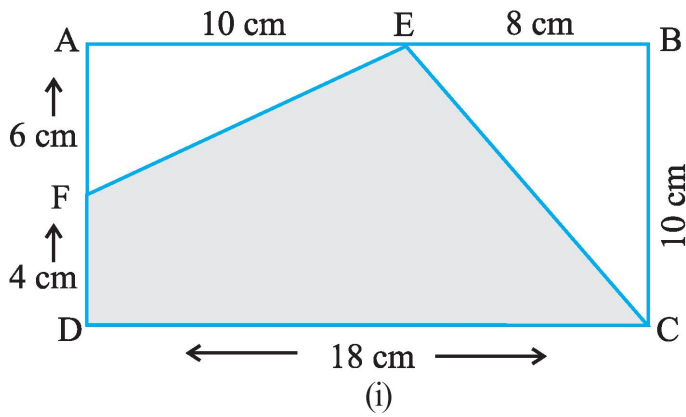

29. The adjoining figure represents a rectangular lawn with a circular flower bed in the middle. Find:
 (i) the area of the whole land (ii) the area of the flower bed
 (iii) the area of the lawn excluding the area of the flower bed
 (iv) the circumference of the flower bed.

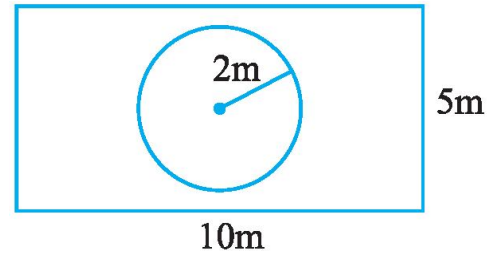

30. Pragya wrapped a cord around a circular pipe of radius 4 cm (adjoining figure) and cut off the length required of the cord. Then she wrapped it around a square box of side 4 cm (also shown). Did she have any cord left? ($\pi = 3.14$)

31. In Fig., ABCD is a square of side 14 cm. With centres A, B, C and D, four circles are drawn such that each circle touch externally two of the remaining three circles. Find the area of the shaded region.

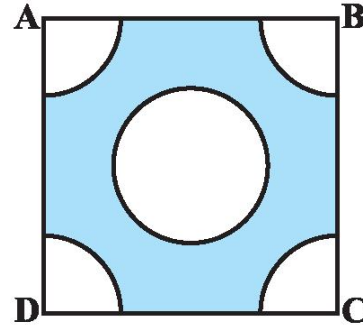
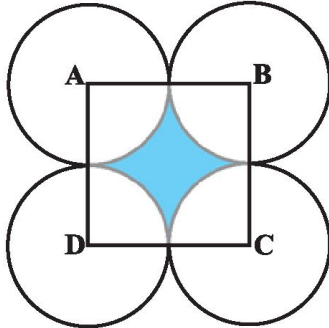

32. From each corner of a square of side 4 cm a quadrant of a circle of radius 1 cm is cut and also a circle of diameter 2 cm is cut as shown in above sided Fig. Find the area of the remaining portion of the square.

33. The cost of fencing a circular field at the rate of Rs 24 per metre is Rs 5280. The field is to be ploughed at the rate of Rs 0.50 per m². Find the cost of ploughing the field.

34. The radii of two circles are 8 cm and 6 cm respectively. Find the radius of the circle having area equal to the sum of the areas of the two circles.

35. The radii of two circles are 19 cm and 9 cm respectively. Find the radius of the circle which has circumference equal to the sum of the circumferences of the two circles.



MCQ WORKSHEET-I
CLASS VII: CHAPTER - 12
ALGEBRAIC EXPRESSIONS

1. What are the coefficients of x in the expression $8 - x + y$?
(a) 1 (b) -1 (c) 8 (d) none of these
 2. What are the coefficients of y in the expression $4x - 3y$?
(a) 4 (b) -3 (c) 3 (d) none of these
 3. What are the coefficients of y in the expression $yz^2 + 5$?
(a) 5 (b) z (c) z^2 (d) none of these
 4. Write the expression for the statement: the sum of three times x and 11
(a) $x + 3 + 11$ (b) $3x + 11$ (c) $3 + 11x$ (d) $3x - 11$
 5. Write an expression : Raju s father s age is 5 years more than 3 times Raju s age . If Raju s age is x years , then father's age is
(a) $3x+5$ (b) $5-3x$ (c) $3x-5$ (d) $15x$
 6. Identify the coefficient of x in expression $8 - x + y$
(a) 0 (b) 8 (c) -1 (d) 1
 7. The number of terms in $4p^2q - 3pq^2 + 5$ is
(a) 7 (b) 3 (c) 1 (d) 4
 8. The expression for sum of numbers a and b subtracted from their product is
(a) $a + b - ab$ (b) $ab - a + b$ (c) $ab - (a+b)$ (d) $ab + a - b$.
 9. The sum of $mn + 5 - 2$ and $mn+3$ is
(a) $2mn + 3$ (b) 6 (c) $2mn + 8$ (d) $2mn + 6$.
 10. What is the statement for the expression $3mn + 5$
(a) 5 more than $\frac{1}{3}$ of product of m and n
(b) number 5 added to product of number m and n
(c) number 5 added to 3 times the product of m and n .
(d) 5 more than 3 times the product of the numbers m and n
 11. The constant term in the expression $1 + x^2 + x$ is
(a) 1 (b) 2 (c) x (d) x^2
 12. The coefficient of y^3 in the expression $y - y^3 + y^2$ is
(a) 1 (b) y (c) $-y^3$ (d) -1
-

MCQ WORKSHEET-II
CLASS VII: CHAPTER - 12
ALGEBRAIC EXPRESSIONS

1. The number of terms in the expression $1.2ab - 2.4b + 3.6a$ is
(a) 1.2 (b) -2.4 (c) 3.6a (d) 3
2. What is the numerical coefficient of y^2 in the expression $2x^2y - 15xy^2 + 7y$
(a) $-15x$ (b) -15 (c) 2 (d) 7
3. The expression $x + y - xy$ is
(a) Monomial (b) Binomial (c) Trinomial (d) Quadrinomial
4. The expression xyz is
(a) Monomial (b) Binomial (c) Trinomial (d) Zero polynomial
5. From the following expressions $10pq, 7p, 8q, -p^2q^2, -7pq, -23, ab, 3a, b$. The like terms are
(a) $3, 7p$ (b) $10pq, -7pq$ (c) $ab, 3a, b$ (d) $10pq, 7p, 8q$
6. From the following expressions $3ab, a^2, b^2, a, 5ab, -2ab, 2a^2$ the three terms are
(a) $3ab, 5ab, -2ab$ (b) $a^2, a, 2a^2$ (c) $3ab, a^2, b^2$ (d) $2a^2, a^2, a$
7. Sum of $3m$ and $2n$ is
(a) $5mn$ (b) $3m+2n$ (c) $5m$ (d) $5n$
8. Sum of $xy, x+y$ and $y+xy$ is
(a) $2xy + 2x+y$ (b) $3xy+2y$ (c) $2xy + x+y$ (d) $2xy+x+2y$
9. The value of $21b - 32 + 7b - 20b$ is
(a) $48b - 32$ (b) $-8b - 32$ (c) $8b - 32$ (d) $28b - 52$
10. Subtract $a - b$ from $a + b$ the result is
(a) $2a + 2b$ (b) $2a$ (c) $2b$ (d) $2a - 2b$
11. Subtracting $-5y^2$ from y^2 , the result is
(a) $-4y^2$ (b) $6y^2$ (c) $4y^2$ (d) $-6y^2$
12. The value of expression $5n - 2$, when $n = -2$ is
(a) -12 (b) 8 (c) 1 (d) -8
13. The value of expression $7a - 4b$ for $a = 3, b = 2$ is
(a) 13 (b) $7a - 6b$ (c) $21a - 8b$ (d) 29
14. When $x = 0, y = -1$, then the value of expression $2x + 2y$ is
(a) 4 (b) 0 (c) -2 (d) 2
15. Factors of the term $15x^2$ in the expression $15x^2 - 13x$ are
(a) 15, x, x (b) 15, -13 (c) $15x^2, -13x$ (d) 15

MCQ WORKSHEET-III
CLASS VII: CHAPTER - 12
ALGEBRAIC EXPRESSIONS

1. Factors of the terms $-4pq^2$ in the expression $9p^2q^2 - 4pq^2$ are
(a) $9p^2q^2, -4pq^2$ (b) $9, -4$ (c) $-4, p, q, q$ (d) -4
2. If the length of each side of the equilateral triangle is l , then the perimeter of the equilateral triangle is
(a) $3l$ (b) $3+l$ (c) $3-l$ (d) $l/3$
3. Which of the following is monomial
(a) $2x + 3$ (b) $2x$ (c) $4x + 2y + 3$ (d) $4y + 5x + z - 1$
4. Which of the following is trinomial
(a) $2a + 6b - 1$ (b) 1 (c) $5a - 7$ (d) $a + b + c - 3$
5. Terms with factors y in the expression $8 + xy + xyz$ are
(a) xy, xyz (b) x, xz (c) $8, xy, xyz$ (d) y, xz
6. Identify the terms in the expression $x + y + 1$ which are not constant
(a) $x, y, 1$ (b) x, y (c) $x, 1$ (d) $y, 1$
7. The value of expression $4x - 3$ at $x=2$ is
(a) -4 (b) 5 (c) 4 (d) 2
8. The value of expression $5n^2 + 5n - 2$ for $n = -2$ is
(a) 13 (b) 3 (c) 8 (d) 12
9. The value of expression $2a^2 + 2b^2 - ab$ for $a=2, b=1$ is
(a) 2 (b) 8 (c) 6 (d) 10
10. The value of $x + 7 + 4(x - 5)$ for $x=2$
(a) -3 (b) 31 (c) 12 (d) 37
11. The value of expression $2a - 2b - 4 - 5 + a$ at $a=1, b=-2$
(a) 10 (b) -2 (c) 12 (d) -4
12. What must be subtracted from $2a + b$ to get $2a - b$
(a) $2b$ (b) $4a$ (c) 0 (d) $4a+4b$
13. What must be added to $3x + y$ to get $2x + 3y$
(a) $5x + 4y$ (b) $-x + 2y$ (c) $x - 2y$ (d) $x + 2y$
14. Subtract $a + 2b$ from sum of $a - b$ and $2a+b$
(a) $2a - 2b$ (b) $4a + 2b$ (c) $2b$ (d) $-2a + 2b$
15. On simplifying $(a + b - 3) - (b - a + 3) + (a - b + 3)$ the result is
(a) $a - b + 3$ (b) $a - b - 3$ (c) $3a - b - 3$ (d) $3a+b+3$
16. What should be value of 'a' if $y^2 + y - a$ equals to 3 for $y=1$
(a) -1 (b) -5 (c) 5 (d) 0

17. What is an expression for the statement: “p is multiplied by 16”
(a) 16p (b) p/16 (c) p+16 (d) p-16
18. The expression for the statement: “ y multiplied by 10 and then 7 added to product”.
(a) $10 + y + 7$ (b) $7y + 10$ (c) $10y + 7$ (d) $10y$
19. What is the statement for the expression $2y - 9$
(a) 2y subtracted from 9 (b) 9 subtracted from y and multiplied by 2
(c) 9 subtracted from 9 (d) thrice of y minus 9
20. Give expression for: “ 5 times of ‘y’ to which 3 is added”
(a) $y + 15$ (b) $5y + 3$ (c) $\frac{5}{y} + 3$ (d) $3y + 5$
21. The equation for the statement: one fourth of a number minus 4 gives 4.
(a) $4x - 4 = 4$ (b) $\frac{4}{x} - 4 = 4$ (c) $\frac{1}{4}x - 4 = 4$ (d) $x - 4 = \frac{1}{4}$
-

PRACTICE QUESTIONS
CLASS VII: CHAPTER - 12
ALGEBRAIC EXPRESSIONS

1. Identify, in the following expressions, terms which are not constants. Give their numerical coefficients: $xy + 4$, $13 - y^2$, $13 - y + 5y^2$, $4p^2q - 3pq^2 + 5$
2. (a) What are the coefficients of x in the following expressions? $4x - 3y$, $8 - x + y$, $y^2x - y$, $2z - 5xz$
(b) What are the coefficients of y in the following expressions? $4x - 3y$, $8 + yz$, $yz^2 + 5$, $my + m$
3. Classify the following expressions as a monomial, a binomial or a trinomial: a , $a + b$, $ab + a + b$, $ab + a + b - 5$, xy , $xy + 5$, $5x^2 - x + 2$, $4pq - 3q + 5p$, 7 , $4m - 7n + 10$, $4mn + 7$.
4. Collect like terms and simplify the expression: $12m^2 - 9m + 5m - 4m^2 - 7m + 10$
5. Add and subtract
 - (i) $m - n$, $m + n$
 - (ii) $mn + 5 - 2$, $mn + 3$
6. Subtract $24ab - 10b - 18a$ from $30ab + 12b + 14a$.
7. From the sum of $2y^2 + 3yz$, $-y^2 - yz - z^2$ and $yz + 2z^2$, subtract the sum of $3y^2 - z^2$ and $-y^2 + yz + z^2$.
8. Classify the following polynomials as monomials, binomials, trinomials.
 $-z + 5$, $x + y + z$, $y + z + 100$, $ab - ac$, 17
9. Construct
 - (a) 3 binomials with only x as a variable;
 - (b) 3 binomials with x and y as variables;
 - (c) 3 monomials with x and y as variables;
 - (d) 2 polynomials with 4 or more terms.
10. Add:
 - (i). $t - 8tz$, $3tz - z$, $z - t$
 - (ii). $7mn + 5$, $12mn + 2$, $9mn - 8$, $-2mn - 3$
 - (iii). $a + b - 3$, $b - a + 3$, $a - b + 3$
 - (iv). $14x + 10y - 12xy - 13$, $18 - 7x - 10y + 8xy$, $4xy$
 - (v). $5m - 7n$, $3n - 4m + 2$, $2m - 3mn - 5$
11. Add: $7xy + 5yz - 3zx$, $4yz + 9zx - 4y$, $-3xz + 5x - 2xy$.
12. Subtract $5x^2 - 4y^2 + 6y - 3$ from $7x^2 - 4xy + 8y^2 + 5x - 3y$.
13. Subtract $4a - 7ab + 3b + 12$ from $12a - 9ab + 5b - 3$
14. Subtract $3xy + 5yz - 7zx$ from $5xy - 2yz - 2zx + 10xyz$
15. Subtract $4p^2q - 3pq + 5pq^2 - 8p + 7q - 10$ from $18 - 3p - 11q + 5pq - 2pq^2 + 5p^2q$

16. (a) What should be added to $x^2 + xy + y^2$ to obtain $2x^2 + 3xy$?
 (b) What should be subtracted from $2a + 8b + 10$ to get $-3a + 7b + 16$?
17. What should be taken away from $3x^2 - 4y^2 + 5xy + 20$ to obtain $-x^2 - y^2 + 6xy + 20$?
18. (a) From the sum of $3x - y + 11$ and $-y - 11$, subtract $3x - y - 11$.
 (b) From the sum of $4 + 3x$ and $5 - 4x + 2x^2$, subtract the sum of $3x^2 - 5x$ and $-x^2 + 2x + 5$.
19. Find the value of the following expressions for $a = 3, b = 2$.
 (i) $a + b$
 (ii) $7a - 4b$
 (iii) $a^2 + 2ab + b^2$
 (iv) $a^3 - b^3$
20. Find the value of the following expressions when $n = -2$.
 (i) $5n - 2$
 (ii) $5n^2 + 5n - 2$
 (iii) $n^3 + 5n^2 + 5n - 2$
21. Find the value of the following expressions for $a = 3, b = 2$.
 (i) $a + b$ (ii) $7a - 4b$ (iii) $a^2 + 2ab + b^2$ (iv) $a^3 - b^3$
22. What should be the value of a if the value of $2x^2 + x - a$ equals to 5, when $x = 0$?
23. Simplify the expression and find its value when $a = 5$ and $b = -3$.
 $2(a^2 + ab) + 3 - ab$
24. If $p = -10$, find the value of $p^2 - 2p - 100$
25. Use the given algebraic expression to complete the table of number patterns.

S. No.	Expression	Terms									
		1 st	2 nd	3 rd	4 th	5 th	...	10 th	...	100 th	...
(i)	$2n - 1$	1	3	5	7	9	-	19	-	-	-
(ii)	$3n + 2$	2	5	8	11	-	-	-	-	-	-
(iii)	$4n + 1$	5	9	13	17	-	-	-	-	-	-
(iv)	$7n + 20$	27	34	41	48	-	-	-	-	-	-
(v)	$n^2 + 1$	2	5	10	17	-	-	-	-	10,001	-

MCQ WORKSHEET-I
CLASS VII: CHAPTER - 13
EXPONENTS AND POWERS

1. Express 256 as a power 4.
(a) 4^8 (b) 2^8 (c) 4^4 (d) none of these
2. Express 729 as a power of 3
(a) 3^8 (b) 3^6 (c) 9^3 (d) none of these
3. Express 2048 as a power 2.
(a) 2^{16} (b) 2^8 (c) 4^8 (d) none of these
4. Which one is greater?
(a) 2^3 (b) 3^2 (c) 1^8 (d) 4^2
5. Express 432 as a product of powers of prime factors.
(a) $2^3 \times 3^3$ (b) $2^4 \times 3^3$ (c) 16×27 (d) none of these
6. The value of $(-1)^{55}$ is
(a) -1 (b) 1 (c) 0 (d) none of these
7. The value of $(-1)^{500}$ is
(a) -1 (b) 1 (c) 0 (d) none of these
8. The value of 2^8 is
(a) 128 (b) 256 (c) 512 (d) none of these
9. Simplify and write in exponential form of $2^2 \times 2^5$
(a) 2^3 (b) 2^7 (c) 128 (d) none of these
10. Simplify and write in exponential form of $(-4)^{100} \times (-4)^{20}$
(a) $(-4)^{120}$ (b) $(-4)^{80}$ (c) $(-4)^{2000}$ (d) none of these
11. Simplify and write in exponential form of $5^2 \times 5^7 \times 5^{12}$
(a) 5^3 (b) 5^7 (c) 5^{21} (d) none of these
12. The value of 2^2
(a) 3 (b) 10 (c) 4 (d) 7
13. The exponent in the expression 3^7 is _____ .
(a) 1 (b) 7 (c) 0 (d) 3
14. The value of 3^0 is _____ .
(a) 0 (b) 3 (c) 1 (d) None of these
15. Multiplicative inverse of $\frac{1}{7}$ is _____ .
(a) 49 (b) 5 (c) 7 (d) -14

MCQ WORKSHEET-II
CLASS VII: CHAPTER - 13
EXPONENTS AND POWERS

1. Fill in the Blank $a^m \div a^n = a^{\dots\dots\dots}$ Where m and n are natural numbers:-
(a) mn (b) m + n (c) m - n (d) m \div n
 2. Express $(2a)^4$ in exponential form.
(a) $4a^3$ (b) $16a^4$ (c) $2a^4$ (d) $8a^4$
 3. The value of $\frac{1}{3^2}$ is equal to _____ .
(a) $\frac{1}{9}$ (b) 1 (c) -6 (d) $\frac{1}{3}$
 4. Find the value of 11^2
(a) 22 (b) 9 (c) 121 (d) 13
 5. In simplified form $(3^0 + 4^0 + 5^0)^0$ is equals to
(a) 12 (b) 3 (c) 12 (d) 1
 6. Find the value of $\left(\frac{2}{3}\right)^2$
(a) $\frac{4}{9}$ (b) $\frac{9}{4}$ (c) $\frac{-2}{9}$ (d) 0
 7. In standard form 52,00,00,000 is equal to _____ .
(a) 5.2×10^7 (b) 5.2×10^8 (c) 52×10^8 (d) $52 \times 100,00,000$
 8. Usual form of the expression 10^4 is given by _____ .
(a) 100,00 (b) 1,0000 (c) 10×10^4 (d) 10,000
 9. 1 micron is equals to _____ .
(a) $\frac{1}{1000000}$ m (b) 10^6 m (c) 10^5 m (d) 10^7 m
 10. The approximate distance of moon from the earth is 384,467,000 m and in exponential form this distance can be written as _____ .
(a) $3.84,467 \times 10^8$ m (b) $384,467 \times 10^{-8}$ m (c) $384,467 \times 10^{-9}$ m (d) $3.844,67 \times 10^{-13}$ m
 11. 7×10^{-5} m is the standard form of which of the following _____ .
(a) 0.0007 m (b) 0.000007 m (c) 0.0000007 m (d) 0.00007 m
 12. The standard form of 4050000 is given by _____ .
(a) 4.05×10^6 (b) 40.5×10^9 (c) 405×10^6 (d) 4.05×10^{-6}
-

MCQ WORKSHEET-III
CLASS VII: CHAPTER - 13
EXPONENTS AND POWERS

1. Which one of the following is the value of 1^{15}
(a) 0 (b) 15 (c) 1 (d) None of these
2. Fill in the blank : $(-1)^{\text{even number}} = \underline{\hspace{2cm}}$.
(a) $2 \times (-1)$ (b) 1 (c) 0 (d) -1^3
3. Fill in the blank : $(-1)^{\text{odd number}} = \underline{\hspace{2cm}}$.
(a) 1 (b) -1 (c) 2 (d) 0
4. Value of $(3^0 + 2^0) \times 5^0$ is
(a) 1 (b) 25 (c) 2 (d) 0
5. The value of 7^2 is $\underline{\hspace{2cm}}$.
(a) 7 (b) 49 (c) 2 (d) 14
6. The Base in the expression 8^{10} is $\underline{\hspace{2cm}}$.
(a) 10 (b) 2 (c) 8 (d) 800
7. The value of 100^0 is $\underline{\hspace{2cm}}$.
(a) 0 (b) 100 (c) 1 (d) None of these
8. Find the number from the following expanded form : $9 \times 10^5 + 2 \times 10^2 + 3 \times 10^1$
(a) 900203 (b) 912351 (c) 905302 (d) 900230
9. Value of $(2^3)^2$ is given by $\underline{\hspace{2cm}}$.
(a) 64 (b) 32 (c) 12 (d) None of these
10. The value of $7^2 \div 7^3$ is given by $\underline{\hspace{2cm}}$.
(a) $\frac{1}{7}$ (b) 7 (c) $\frac{1}{14}$ (d) -7
11. The value of $\frac{1}{5^2}$ is equal to -----.
(a) -5 (b) 25 (c) -15 (d) $\frac{1}{25}$
12. In exponential form 140,000,000,000 Kg is given by $\underline{\hspace{2cm}}$.
(a) 1.4×10^{10} Kg (b) 1.4×10^9 Kg (c) 14×10^8 Kg (d) 1.4×10^{11} Kg
13. The expression , $(5^2 + 7^2 + 3^2)^0$ is equals to
(a) 15^6 (b) - 6 (c) 1 (d) 83
14. The value of $\left(\frac{1}{6}\right)^2$ is $\underline{\hspace{2cm}}$.
(a) $\frac{1}{12}$ (b) $\frac{2}{3}$ (c) $\frac{1}{36}$ (d) 2

MCQ WORKSHEET-IV
CLASS VII: CHAPTER - 13
EXPONENTS AND POWERS

1. In standard form 56700000 is written as _____ .
(a) 5.67×10^7 (b) 567×10^7 (c) 5.67×10^5 (d) 567×100000
2. Usual form of the expression 9×10^{-5} is given by _____ .
(a) 0.00009 (b) 0.000009 (c) 90×10^{-4} (d) 0.09×10^{-3}
3. The number 86,800,000,000,000,000,000,000 Kg is equal to _____ .
(a) 8.68×10^{25} Kg (b) 868×10^{23} Kg (c) 86.8×10^{25} Kg (d) 868×10^{23} m
4. Charge of an electron is 0.000,000,000,000,000,000,16 coulomb and in exponential form it can be written as _____ .
(a) 16×10^{-18} coulomb (b) 1.6×10^{-21} coulomb
(c) 1.6×10^{-19} coulomb (d) 16×10^{-21} coulomb
5. 13×10^{-7} Km is the standard form of which of the following _____ .
(a) 0.000000013 Km (b) 0.0000013 Km (c) 0.000000000013 Km (d) 0.00000000013 Km
6. The standard form of 9,030,000,000 is given by _____ .
(a) 9.03×10^9 (b) 90.3×10^7 (c) 903×10^6 (d) 9.03×10^{-9}
7. Which one of the following is the value of 3^5
(a) 3 (b) 15 (c) 2 (d) 243
8. Find the value of $5^0 \times 7^0 \times 3^0$
(a) 1 (b) $\frac{1}{24}$ (c) 6 (d) $\frac{1}{5} \times 7 \times 3$
9. 64 in exponential form is _____ .
(a) 2^6 (b) 16^2 (c) $\frac{1}{8^2}$ (d) 2^4
10. The value of $2^0 \times 3^0 \times 4^0$ is
(a) 1 (b) 0 (c) 24 (d) None of these
11. 1024 in exponential form is _____ .
(a) 2^6 (b) 16^2 (c) $\frac{1}{8^2}$ (d) none of these
12. The value of $\frac{2^2}{3^2}$ in the exponential form is
(a) $\left(\frac{2}{3}\right)^4$ (b) $\left(\frac{2}{3}\right)^2$ (c) $\left(\frac{2}{3}\right)^0$ (d) none of these
-

PRACTICE QUESTIONS
CLASS VII: CHAPTER - 13
EXPONENTS AND POWERS

1. Express:
 - (i) 729 as a power of 3
 - (ii) 128 as a power of 2
 - (iii) 343 as a power of 7
 - (iv) 256 as a power 2.
2. Which one is greater 2^3 or 3^2 ?
3. Which one is greater 8^2 or 2^8 ?
4. Express the following numbers as a product of powers of prime factors:
 - (i) 72 (ii) 432 (iii) 1000 (iv) 16000
5. Express each of the following numbers using exponential notation:
 - (i) 512 (ii) 343 (iii) 729 (iv) 3125
6. Simplify:
 - (i) $(-4)^3$ (ii) $(-3) \times (-2)^3$ (iii) $(-3)^2 \times (-5)^2$ (iv) $(-2)^3 \times (-10)^3$
7. Compare the following numbers:
 - (i) 2.7×10^{12} ; 1.5×10^8 (ii) 4×10^{14} ; 3×10^{17}
8. Simplify and write in exponential form:
 - (i) $2^5 \times 2^3$
 - (ii) $p^3 \times p^2$
 - (iii) $4^3 \times 4^2$
 - (iv) $a^3 \times a^2 \times a^7$
 - (v) $5^3 \times 5^7 \times 5^{12}$
 - (vi) $(-4)^{100} \times (-4)^{20}$
9. Simplify and write in exponential form:
 - (i) $2^9 \div 2^3$
 - (ii) $10^8 \div 10^4$
 - (iii) $9^{11} \div 9^7$
 - (iv) $20^{15} \div 20^{13}$
 - (v) $7^{13} \div 7^{10}$
10. Express the following terms in the exponential form:
 - (i) $(2 \times 3)^5$ (ii) $(2a)^4$ (iii) $(-4m)^3$

11. Simplify and write the answer in exponential form:

(i) 6^{2^4}

(ii) $(2^2)^{100}$

(iii) $(7^{50})^2$

(iv) $(5^3)^7$

12. Expand: (i) $\left(\frac{3}{5}\right)^4$ (ii) $\left(\frac{4}{7}\right)^5$

13. Write exponential form for $8 \times 8 \times 8 \times 8$ taking base as 2.

14. Simplify and write the answer in the exponential form.

(i) $\left(\frac{3^7}{3^2}\right) \times 3^5$ (ii) $2^3 \times 2^2 \times 2^5$ (iii) $(6^2 \times 6^4) \div 6^3$

(iv) $\left[(2^2)^3 \times 3^6\right] \times 5^6$ (v) $8^2 \div 2^3$

15. Simplify:

(i) $\frac{12^4 \times 9^3 \times 4}{6^3 \times 8^2 \times 27}$ (ii) $2^3 \times a^3 \times 5a^4$ (iii) $\frac{2 \times 3^4 \times 2^5}{9 \times 4^2}$

16. Express each of the following as a product of prime factors only in exponential form:

(i) 108×192 (ii) 270 (iii) 729×64 (iv) 768

17. Simplify:

(i) $\frac{(2^5)^2 \times 7^3}{8^3 \times 7}$ (ii) $\frac{25 \times 5^2 \times t^8}{10^3 \times t^4}$ (iii) $\frac{3^5 \times 10^5 \times 25}{5^7 \times 6^5}$

18. Write the following numbers in standard form.

(i) 0.000000564

(ii) 0.0000021

(iii) 21600000

(iv) 15240000

(v) 6020000000000000

19. Express the following numbers in standard form.

(i) 0.0000000000000000000000035

(ii) 4050000000000

(iii) 51000000000000000000

(iv) 0.000000000000000000000000000625

(v) 0.0000000000000001257

20. Express the following numbers in usual form.

(i) 3.52×10^5

(ii) 7.54×10^{-4}

(iii) 3×10^{-5}

(iv) 5.25×10^{-7}

(v) 8.525×10^9

21. Express the number appearing in the following statements in standard form.

(i) 1 micron is equal to $\frac{1}{1000000}$ m.

(ii) Charge of an electron is 0.000,000,000,000,000,16 coulomb.

(iii) Size of a bacteria is 0.0000005 m

(iv) Size of a plant cell is 0.00001275 m

(v) Thickness of a thick paper is 0.07 mm

(vi) Mass of Uranus = 86,800,000,000,000,000,000,000 kg

(vii) Mass of the Earth = 5,976,000,000,000,000,000,000,000 kg

(viii) Distance of Sun from the centre of our Galaxy = 300,000,000,000,000,000,000 m

(ix) Sun is located 300,000,000,000,000,000,000 m from the centre of our Milky Way Galaxy.

(x) The distance between Sun and Saturn is 1,433,500,000,000 m



MCQ WORKSHEET-I
CLASS VII: CHAPTER - 14
SYMMETRY

1. Which of the followings has both horizontal as well as vertical line of symmetry:
(a) S (b) A (c) U (d) H
2. The mirror image of 'W', when the mirror is placed vertically:
(a) V (b) M (c) Σ (d) W
3. Number of lines of symmetry a triangle does not have:
(a) 1 (b) 2 (c) 3 (d) 0
4. A parallelogram has _____ lines of symmetry:
(a) 0 (b) 1 (c) 2 (d) 3
5. Which of the following alphabets has line symmetry ?
(a) P (b) Z (c) A (d) Q
6. How many lines of symmetries are there in an equilateral triangle?
(a) 1 (b) 2 (c) 3 (d) 4
7. Which of the following letters have reflection line of symmetry about vertical mirror?
(a) B (b) C (c) V (d) Q
8. How many lines of symmetries are there in an isosceles triangle ?
(a) 1 (b) 2 (c) 3 (d) 4
9. How many lines of symmetries are there in a rhombus?
(a) 1 (b) 2 (c) 3 (d) 4
10. How many lines of symmetries are there in a square?
(a) 1 (b) 2 (c) 3 (d) 4
11. How many lines of symmetries are there in regular pentagon?
(a) 1 (b) 2 (c) 3 (d) 4
12. How many lines of symmetries are there in rectangle?
(a) 1 (b) 2 (c) 3 (d) 4
13. Find the number of lines of symmetry of the following figure:
(a) 1 (b) 2 (c) 3 (d) 4

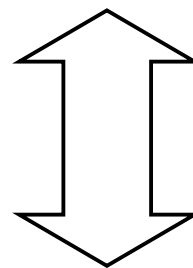
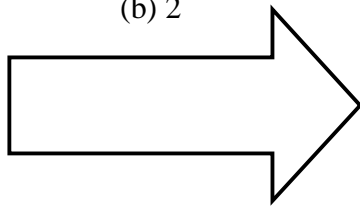

14. Find the number of lines of symmetry of the following figure:
(a) 1 (b) 2 (c) 3 (d) 4

MCQ WORKSHEET-II
CLASS VII: CHAPTER - 14
SYMMETRY

1. Find the number of lines of symmetry in regular hexagon.
(a) 1 (b) 2 (c) 3 (d) 4
2. Letter 'A' of the English alphabet have reflectional symmetry (i.e., symmetry related to mirror reflection) about.
(a) a vertical mirror (b) a horizontal mirror (c) both (a) and (b) (d) none of these
3. Letter 'B' of the English alphabet have reflectional symmetry (i.e., symmetry related to mirror reflection) about.
(a) a vertical mirror (b) a horizontal mirror (c) both (a) and (b) (d) none of these
4. Letter 'C' of the English alphabet have reflectional symmetry (i.e., symmetry related to mirror reflection) about.
(a) a vertical mirror (b) a horizontal mirror (c) both (a) and (b) (d) none of these
5. Letter 'D' of the English alphabet have reflectional symmetry (i.e., symmetry related to mirror reflection) about.
(a) a vertical mirror (b) a horizontal mirror (c) both (a) and (b) (d) none of these
6. Letter 'E' of the English alphabet have reflectional symmetry (i.e., symmetry related to mirror reflection) about.
(a) a vertical mirror (b) a horizontal mirror (c) both (a) and (b) (d) none of these
7. Letter 'E' of the English alphabet have reflectional symmetry (i.e., symmetry related to mirror reflection) about.
(a) a vertical mirror (b) a horizontal mirror (c) both (a) and (b) (d) none of these
8. Letter 'G' of the English alphabet have reflectional symmetry (i.e., symmetry related to mirror reflection) about.
(a) a vertical mirror (b) a horizontal mirror (c) both (a) and (b) (d) none of these
9. Letter 'H' of the English alphabet have reflectional symmetry (i.e., symmetry related to mirror reflection) about.
(a) a vertical mirror (b) a horizontal mirror (c) both (a) and (b) (d) none of these
10. Letter 'T' of the English alphabet have reflectional symmetry (i.e., symmetry related to mirror reflection) about.
(a) a vertical mirror (b) a horizontal mirror (c) both (a) and (b) (d) none of these
11. Letter 'M' of the English alphabet have reflectional symmetry (i.e., symmetry related to mirror reflection) about.
(a) a vertical mirror (b) a horizontal mirror (c) both (a) and (b) (d) none of these
12. Letter 'T' of the English alphabet have reflectional symmetry (i.e., symmetry related to mirror reflection) about.
(a) a vertical mirror (b) a horizontal mirror (c) both (a) and (b) (d) none of these

MCQ WORKSHEET-III
CLASS VII: CHAPTER - 14
SYMMETRY

1. Find the number of lines of symmetry in the below left figure:

- (a) 1 (b) 2 (c) 3 (d) 4

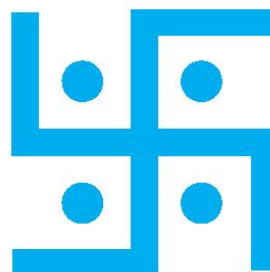
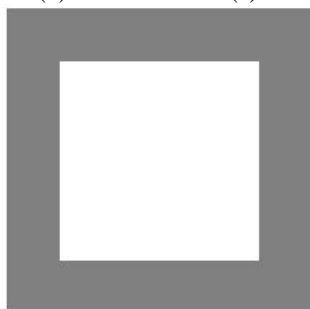

2. Find the number of lines of symmetry in the above right sided figure:

- (a) 1 (b) 2 (c) 3 (d) 4

3. Find the number of lines of symmetry in the below left figure:

- (a) 1 (b) 2 (c) 3 (d) 4

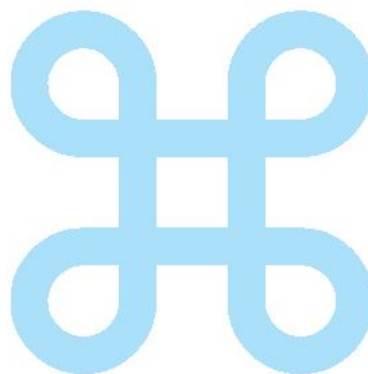
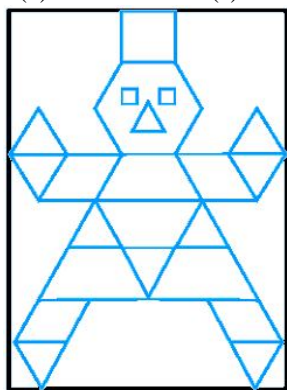

4. Find the number of lines of symmetry in the above right sided figure:

- (a) 1 (b) 2 (c) 3 (d) 4

5. Find the number of lines of symmetry in a circle.

- (a) 1 (b) 2 (c) 3 (d) none of these

6. Which of the followings has no line of symmetry:

- (a) S (b) A (c) U (d) H

7. Which of the followings has both horizontal as well as vertical line of symmetry:

- (a) Z (b) B (c) P (d) I

8. Which letter look the same after reflection when the mirror is placed vertically.

- (a) S (b) P (c) Q (d) H

9. Find the number of lines of symmetry in a scalene triangle.

- (a) 0 (b) 1 (c) 2 (d) 3

10. The order of the rotational symmetry of the parallelogram about the centre is

- (a) 0 (b) 1 (c) 2 (d) 3

11. The order of the rotational symmetry of the below left figure about the point marked 'x'

(a) 0

(b) 1

(c) 2

(d) 3

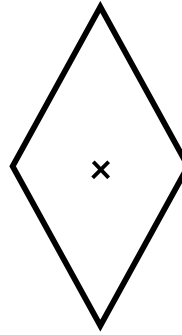
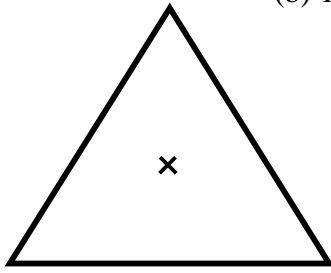

12. The order of the rotational symmetry of the above sided right figure about the point marked 'x'

(a) 0

(b) 1

(c) 2

(d) 3

13. The order of the rotational symmetry of the below left figure about the point marked 'x'

(a) 0

(b) 1

(c) 2

(d) 3

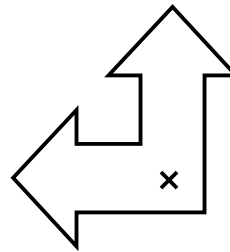
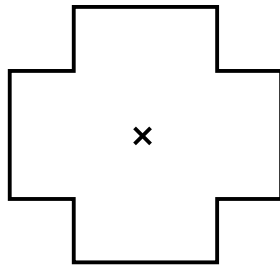

14. The order of the rotational symmetry of the above sided right figure about the point marked 'x'

(a) 0

(b) 1

(c) 2

(d) 3

15. The order of the rotational symmetry of the below left figure about the point marked 'x'

(a) 0

(b) 1

(c) 2

(d) 3

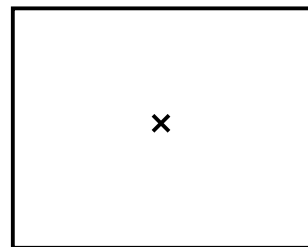
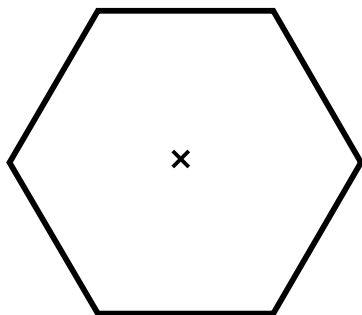

16. The order of the rotational symmetry of the above sided right figure about the point marked 'x'

(a) 0

(b) 1

(c) 2

(d) 3

PRACTICE QUESTIONS
CLASS VII: CHAPTER - 14
SYMMETRY

1. Find the number of lines of symmetry of the following figures:

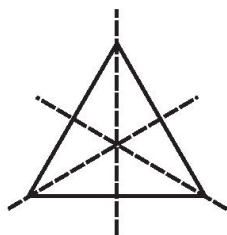

Equilateral Triangle

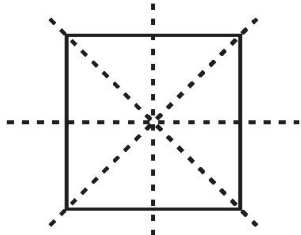

Square

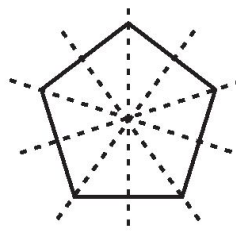

Regular Pentagon

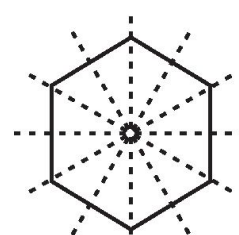

Regular Hexagon

2. Given the line(s) of symmetry, find the other hole(s):

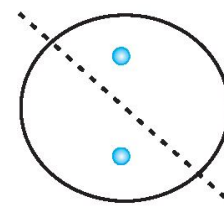
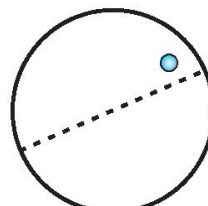
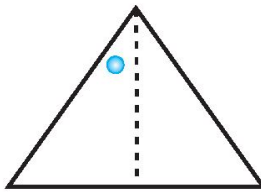
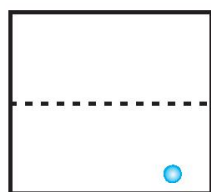
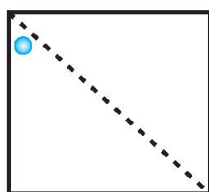

3. The following figures have more than one line of symmetry. Such figures are said to have multiple lines of symmetry.

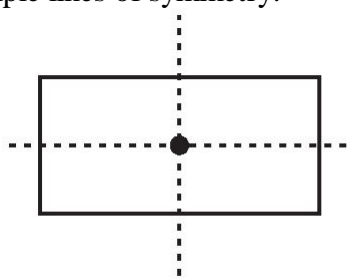

(a)

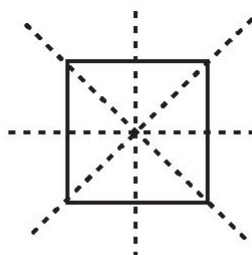

(b)



(c)

Identify multiple lines of symmetry, if any, in each of the following figures:

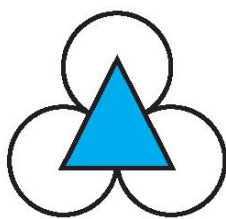

(a)

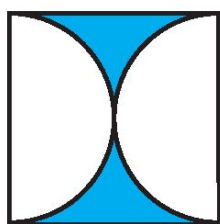

(b)

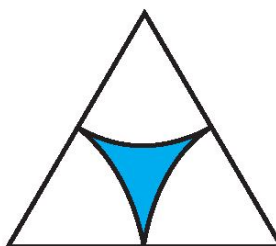

(c)

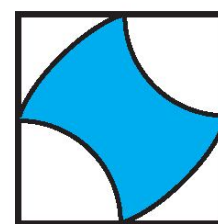

(d)

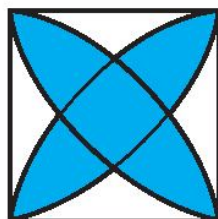

(e)

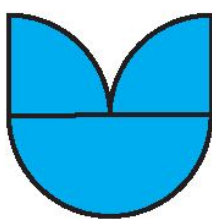

(f)

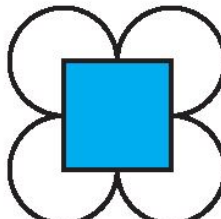

(g)

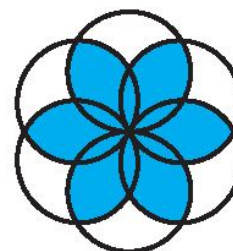

(h)

4. State the number of lines of symmetry for the following figures:
 (a) An equilateral triangle (b) An isosceles triangle (c) A scalene triangle (d) A square
 (e) A rectangle (f) A rhombus (g) A parallelogram (h) A quadrilateral (i) A regular hexagon
 (j) A circle
5. What letters of the English alphabet have reflectional symmetry (i.e., symmetry related to mirror reflection) about?
 (a) a vertical mirror (b) a horizontal mirror (c) both horizontal and vertical mirrors
6. Give the order of the rotational symmetry for an equilateral triangle?

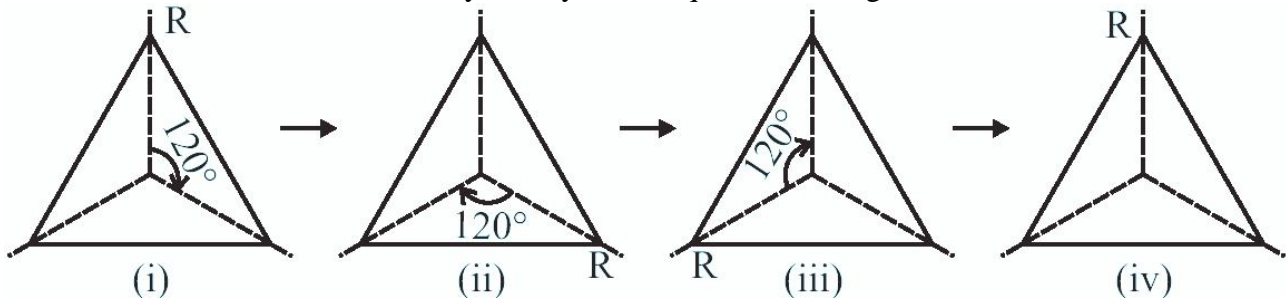

7. How many positions are there in above figures at which the triangle looks exactly the same, when rotated about its centre by 120° ?
8. Which of the following shapes have rotational symmetry about the marked point.

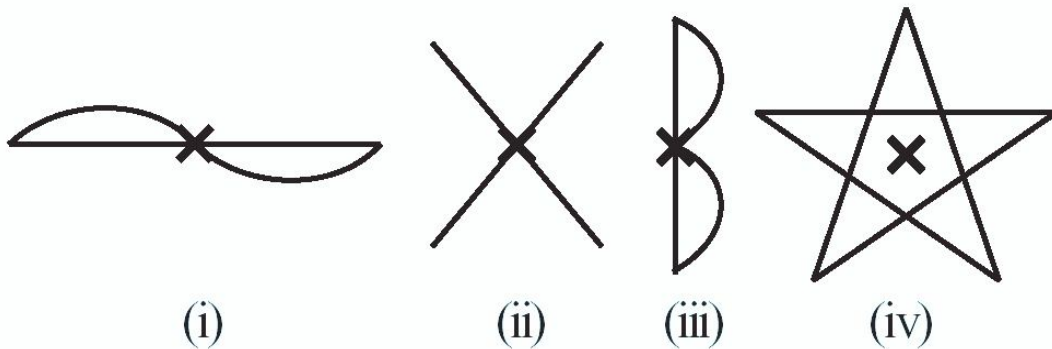

9. Fill in the blanks:

Shape	Centre of Rotation	Order of Rotation	Angle of Rotation
Square			
Rectangle			
Rhombus			
Equilateral Triangle			
Regular Hexagon			
Circle			
Semi-circle			

10. Name any two figures that have both line symmetry and rotational symmetry.
11. Name the quadrilaterals which have both line and rotational symmetry of order more than 1.
12. After rotating by 60° about a centre, a figure looks exactly the same as its original position. At what other angles will this happen for the figure?

13. Give the order of the rotational symmetry of the given figures about the point marked 'x'

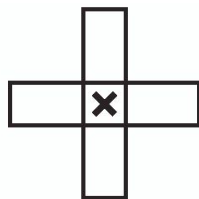

(i)

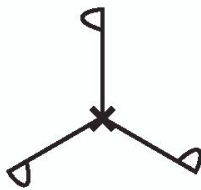

(ii)



(iii)

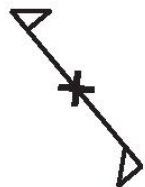

(a)

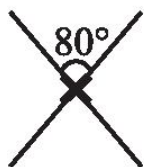

(b)

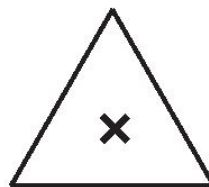

(c)

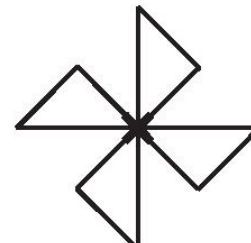

(d)

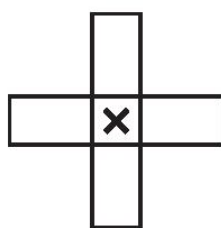

(e)

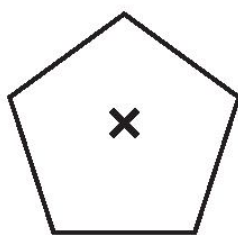

(f)

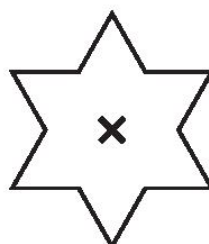

(g)

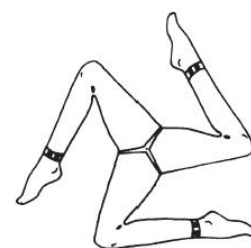

(h)

14. Some of the English alphabets have fascinating symmetrical structures. Complete the following with 'Yes' or 'No'

Alphabet Letters	Line Symmetry	Number of Lines of Symmetry	Rotational Symmetry	Order of Rotational Symmetry
Z				
S				
H				
O				
E				
N				
C				

15. Draw, wherever possible, a rough sketch of

- a triangle with both line and rotational symmetries of order more than 1.
- a triangle with only line symmetry and no rotational symmetry of order more than 1.
- a quadrilateral with a rotational symmetry of order more than 1 but not a line symmetry.
- a quadrilateral with line symmetry but not a rotational symmetry of order more than 1.

16. Find the number of lines of symmetry of the following figures:

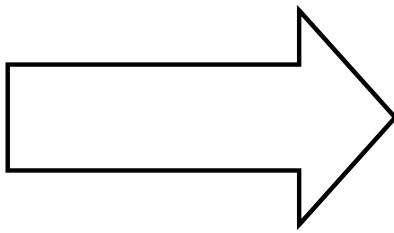

(a)

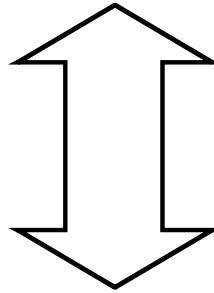

(b)

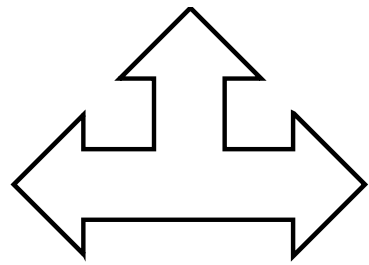

(c)

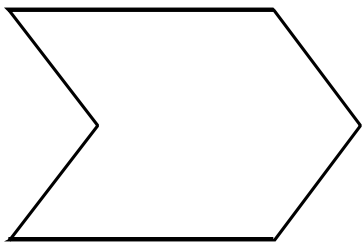

(d)

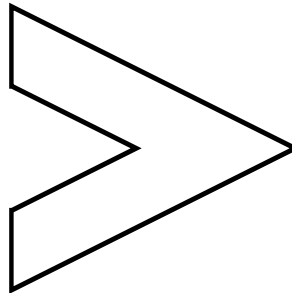

(e)

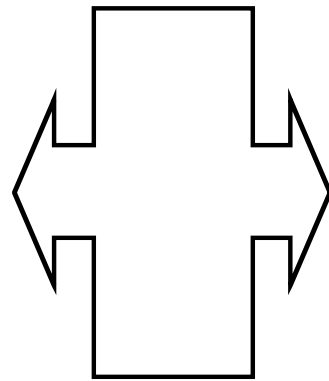

(f)

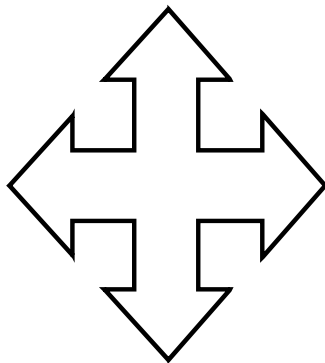

(g)

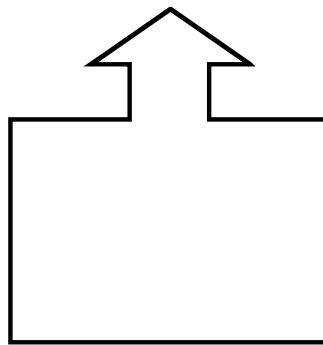

(h)

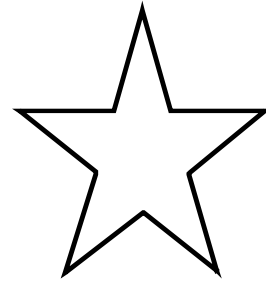

(i)

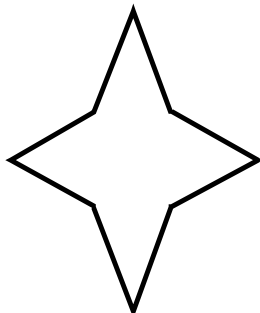

(j)

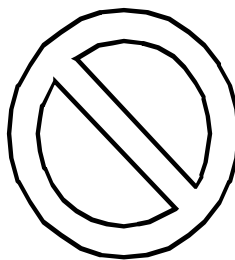

(k)

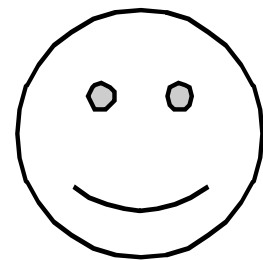

(l)

17. Give the order of the rotational symmetry of the given figures about the point marked 'x'

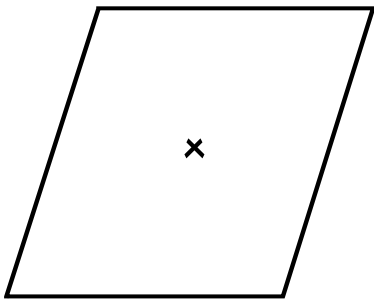

(a)

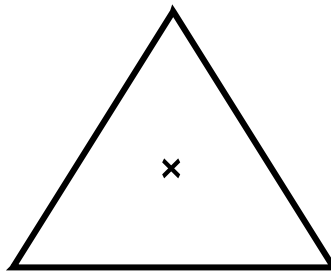

(b)

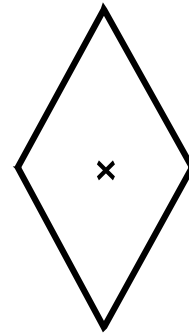

(c)

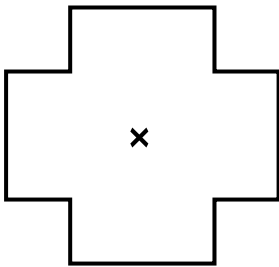

(d)

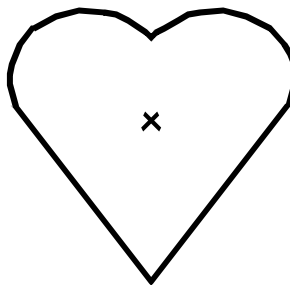

(e)

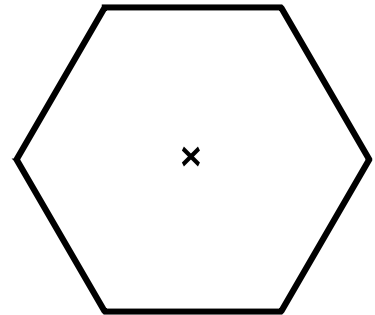

(f)

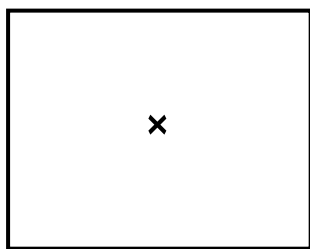

(g)

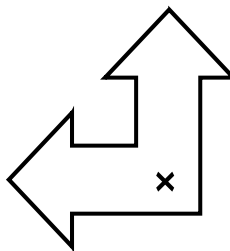

(h)

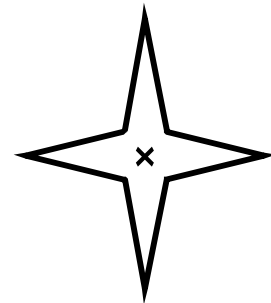

(i)

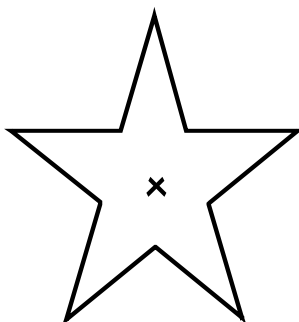

(j)

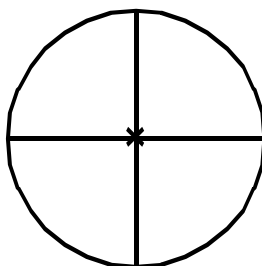

(k)

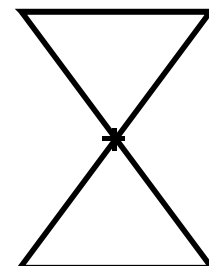

(l)



MCQ WORKSHEET-I
CLASS VII: CHAPTER - 15
VISUALIZING SOLID SHAPES

1. Two cubes of dimensions 2 cm x 2 cm x 2 cm are placed side by side, the length of resulting Cuboid is-
(a) 2 cm (b) 3 cm (c) 4 cm (d) 6 cm
2. The vertical cut of a brick will show the cross section is –
(a) Rectangle (b) Pentagon (c) Triangle (d) None
3. Cuboid is an example of –
(a) 2-D Shape (b) 3-D Shape (c) Both (a) & (b) (d) None
4. Which one is a 3D shape?
(a) Rectangle (b) circle (c) cube (d) square
5. A cuboid has _____ rectangular faces.
(a) 4 (b) 6 (c) 8 (d) 12
6. A cuboid has _____ edges.
(a) 4 (b) 6 (c) 8 (d) 12
7. A cuboid has _____ vertices.
(a) 4 (b) 6 (c) 8 (d) 12
8. The number of faces of a cylinder is _____.
(a) 1 (b) 6 (c) 2 (d) 3
9. The number of faces of a cube is _____.
(a) 1 (b) 6 (c) 2 (d) 3
10. The number of faces of a cone is _____.
(a) 1 (b) 6 (c) 2 (d) 3
11. The number of faces of a sphere is _____.
(a) 1 (b) 6 (c) 2 (d) 3
12. The number of vertices of a cube is _____.
(a) 4 (b) 6 (c) 8 (d) 12
13. The number of vertices of a cone is _____.
(a) 1 (b) 6 (c) 2 (d) 3
14. The number of faces of a triangular prism is _____.
(a) 4 (b) 5 (c) 6 (d) none of these
15. The number of faces of a square pyramid is _____.
(a) 4 (b) 5 (c) 6 (d) none of these

MCQ WORKSHEET-II
CLASS VII: CHAPTER - 15
VISUALIZING SOLID SHAPES

1. The number of faces of a triangular pyramid or tetrahedron is _____.
(a) 4 (b) 5 (c) 6 (d) none of these
2. The number of triangular faces of a triangular prism is _____.
(a) 1 (b) 4 (c) 2 (d) 3
3. The number of rectangular faces of a triangular prism is _____.
(a) 1 (b) 4 (c) 2 (d) 3
4. The number of triangular faces of a rectangular pyramid is _____.
(a) 1 (b) 4 (c) 2 (d) 3
5. The number of rectangular faces of a rectangular pyramid is _____.
(a) 1 (b) 4 (c) 2 (d) 3
6. The number of edges of a triangular prism is _____.
(a) 6 (b) 8 (c) 9 (d) 12
7. The number of edges of a square pyramid is _____.
(a) 6 (b) 8 (c) 9 (d) 12
8. The number of edges of a triangular pyramid is _____.
(a) 6 (b) 8 (c) 9 (d) 12
9. The number of edges of a rectangular pyramid is _____.
(a) 6 (b) 8 (c) 9 (d) 12
10. The number of faces of a triangular prism is _____.
(a) 6 (b) 8 (c) 4 (d) 5
11. The number of faces of a triangular pyramid is _____.
(a) 6 (b) 8 (c) 4 (d) 5
12. The number of faces of a square pyramid is _____.
(a) 6 (b) 8 (c) 4 (d) 5
13. The number of faces of a rectangular prism is _____.
(a) 6 (b) 8 (c) 4 (d) 5
14. The corners of a solid shape are called its _____.
(a) vertices (b) edges (c) faces (d) net
15. A _____ is a skeleton-outline of a solid that can be folded to make it
(a) vertices (b) edges (c) faces (d) net

MCQ WORKSHEET-III
CLASS VII: CHAPTER - 15
VISUALIZING SOLID SHAPES

1. What will be the number of faces if there are 6 vertices and 12 edges?
(a) 8 b)10 c)12 d) 18
2. What will be the number of edges if there are 12 vertices and 20 faces?
(a) 32 b)28 c)30 d)42
3. Which of the following is Euler's Formula:
(a) $F + V - E = 2$ (b) $F + V = E - 2$ (c) $F - V = E - 2$ (d) $F - V + E = 2$

4. Name of the solid given below left figure.
(a) Cylinder b) Cone



- c) Sphere d) Cuboid

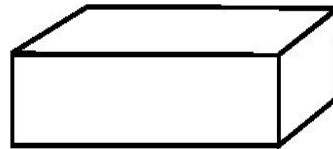

5. Name of the solid given above sided right figure.
(a) Cylinder b) Cone c) Sphere d) Cuboid
6. Name of the solid given below left figure.
(a) Cylinder b) Cone c) Sphere d) Cuboid

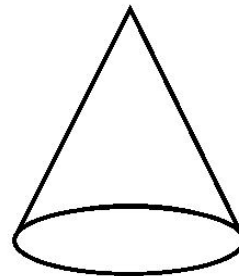
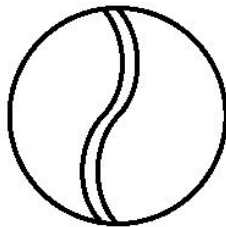

7. Name of the solid given above sided right figure.
(a) Cylinder b) Cone c) Sphere d) Cuboid
8. Name of the solid given below left figure.
(a) Pyramid b) Cone c) Cube d) Cuboid

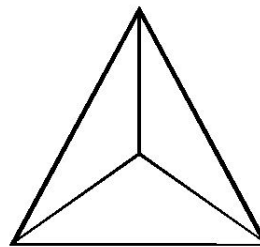
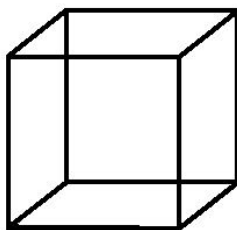

9. Name of the solid given above sided right figure.
(a) Pyramid b) Cone c) Cube d) Cuboid

10. Name of the solid whose net diagram is given in below left figure.

(a) Pyramid

b) Cone

c) Cube

d) Cuboid

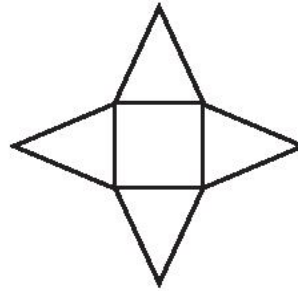
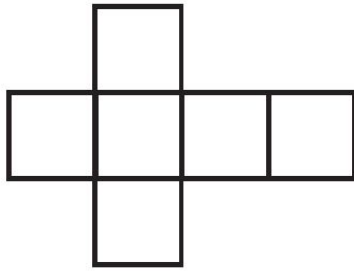

11. Name of the solid whose net diagram is given in above sided right figure.

(a) Pyramid

b) Cone

c) Cube

d) Cuboid

12. Name of the solid whose net diagram is given in below left figure.

(a) Cylinder

b) Cone

c) Sphere

d) Cuboid



13. Name of the solid whose net diagram is given in above sided right figure.

(a) Cylinder

b) Cone

c) Sphere

d) Cuboid

14. Two dice are placed side by side with 5 + 6, what is the total on the face opposite to the given numbers

(a) 3

b) 7

c) 11

d) 6

15. Two dice are placed side by side with 4 + 3, what is the total on the face opposite to the given numbers

(a) 3

b) 7

c) 11

d) 6

MCQ WORKSHEET-IV
CLASS VII: CHAPTER - 15
VISUALIZING SOLID SHAPES

1. Two dice are placed side by side with 2 + 1, what is the total on the face opposite to the given numbers
(a) 3 b) 7 c) 11 d) 6
2. Two dice are placed side by side with 6 + 2, what is the total on the face opposite to the given numbers
(a) 3 b) 7 c) 11 d) 6
3. Two dice are placed side by side with 5 + 2, what is the total on the face opposite to the given numbers
(a) 3 b) 7 c) 11 d) 6
4. What cross-sections do you get when you give a vertical cut to the brick?
(a) rectangle b) square c) circle d) triangle
5. What cross-sections do you get when you give a vertical cut to the round apple?
(a) rectangle b) square c) circle d) triangle
6. What cross-sections do you get when you give a vertical cut to a die?
(a) rectangle b) square c) circle d) triangle
7. What cross-sections do you get when you give a vertical cut to the circular pipe?
(a) rectangle b) square c) circle d) triangle
8. What cross-sections do you get when you give a vertical cut to an ice-cream cone?
(a) rectangle b) square c) circle d) triangle
9. What cross-sections do you get when you give a horizontal cut to the brick?
(a) rectangle b) square c) circle d) triangle
10. What cross-sections do you get when you give a horizontal cut to the round apple?
(a) rectangle b) square c) circle d) triangle
11. What cross-sections do you get when you give a horizontal cut to a die?
(a) rectangle b) square c) circle d) triangle
12. What cross-sections do you get when you give a horizontal cut to the circular pipe?
(a) rectangle b) square c) circle d) triangle
13. What cross-sections do you get when you give a horizontal cut to an ice-cream cone?
(a) rectangle b) square c) circle d) triangle
14. What cross-sections do you get when you give a horizontal cut to cricket ball?
(a) rectangle b) square c) circle d) triangle
15. What cross-sections do you get when you give a vertical cut to cylindrical base?
(a) rectangle b) square c) circle d) triangle

PRACTICE QUESTIONS
CLASS VII: CHAPTER - 15
VISUALIZING SOLID SHAPES

1. Match the shape with the name:

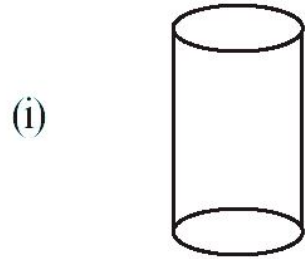

(a) Cuboid

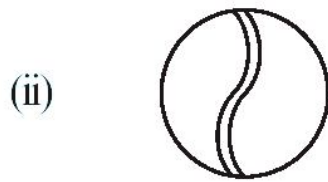

(b) Cylinder



(c) Cube

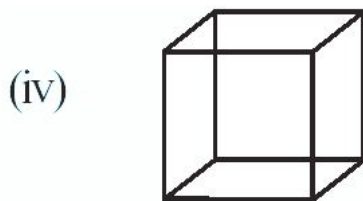

(d) Sphere

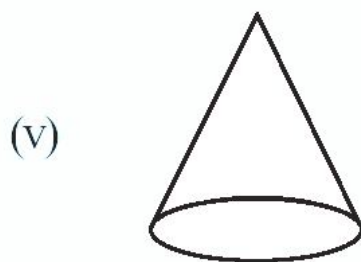

(e) Pyramid

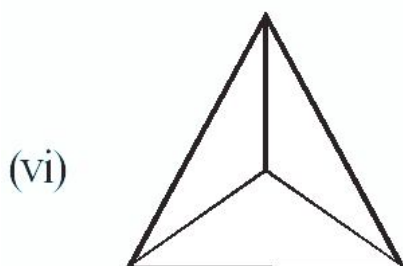

(f) Cone

2. Match the nets with appropriate solids:

(a)

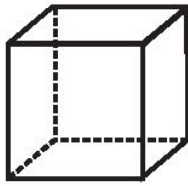

(b)



(c)

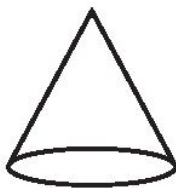

(d)

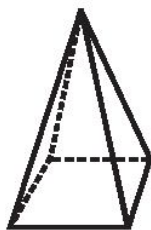

(i)

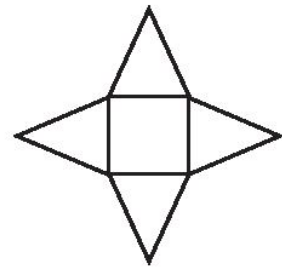

(ii)

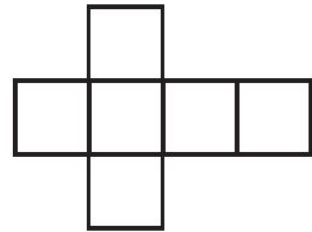

(iii)



(iv)



3. Can this be a net for a die? Explain your answer.

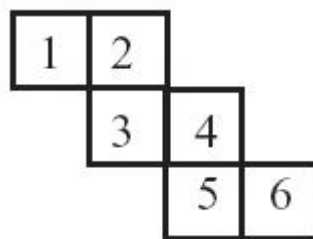

4. The dimensions of a cuboid are 5 cm, 3 cm and 2 cm. Draw three different isometric sketches of this cuboid.
5. Three cubes each with 2 cm edge are placed side by side to form a cuboid. Sketch an oblique or isometric sketch of this cuboid.
6. If two cubes of dimensions 2 cm by 2cm by 2cm are placed side by side, what would the dimensions of the resulting cuboid be?
7. Two dice are placed side by side as shown: Can you say what the total would be on the face opposite to (a) 5 + 6 (b) 4 + 3 (Remember that in a die sum of numbers on opposite faces is 7)

8. Make an oblique sketch for each one of the given isometric shapes:

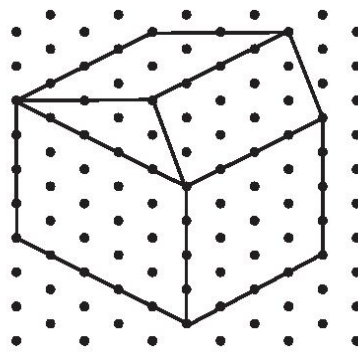
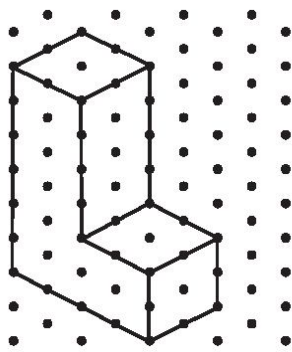

9. Three cubes each with 2 cm edge are placed side by side to form a cuboid. Try to make an oblique sketch and say what could be its length, breadth and height.

10. What cross-sections do you get when you give a (i) vertical cut (ii) horizontal cut to the following solids? (a) A brick (b) A round apple (c) A die (d) A circular pipe (e) An ice cream cone

11. For given solid, draw the top view, front view and side view.

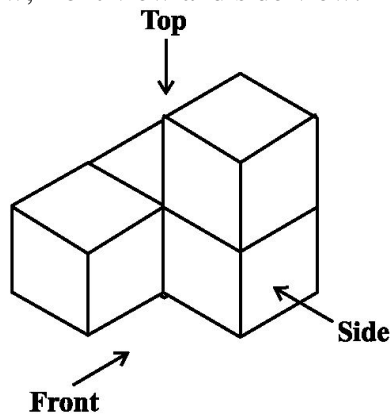

12. For given solid, draw the top view, front view and side view.

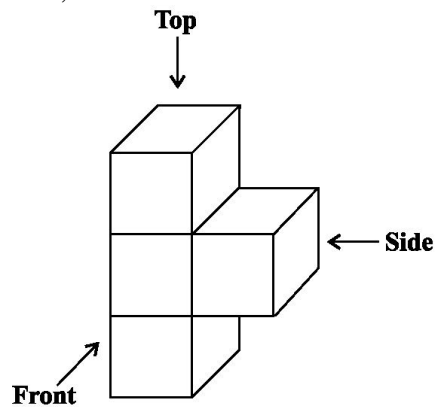

13. For given solid, draw the top view, front view and side view.

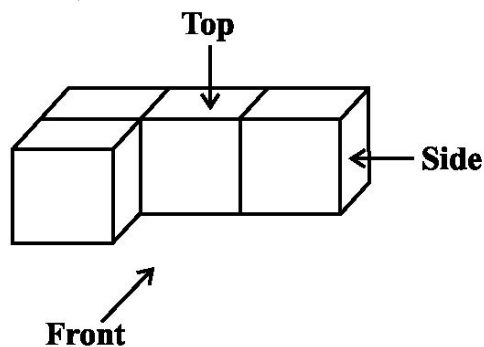

14. For given solid, draw the top view, front view and side view.

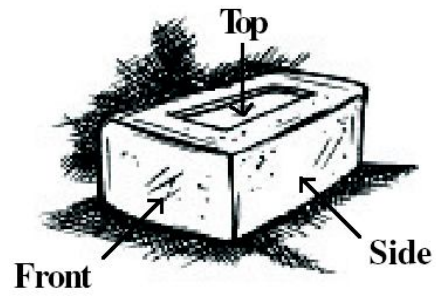

A brick

15. For given solid, draw the top view, front view and side view.

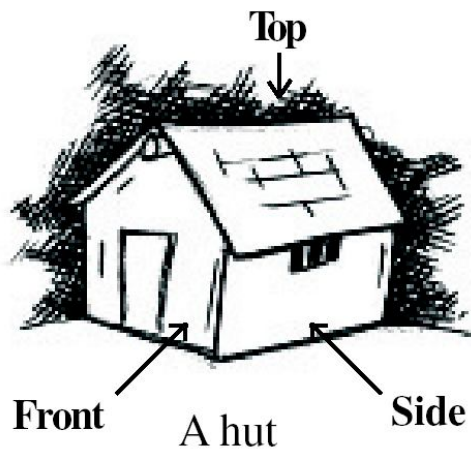

A hut

